

2N5911 / 2N5912

FEATURES

- Tight Tracking
- Low Insertion Loss
- Good Matching

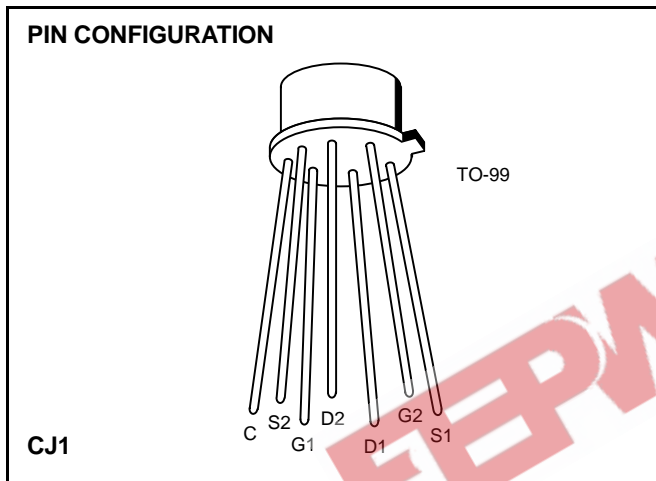

ABSOLUTE MAXIMUM RATINGS

($T_A = 25^\circ\text{C}$ unless otherwise specified)

Gate-Drain or Gate-Source Voltage	-25V
Gate Current	50mA
Storage Temperature Range	-65°C to +200°C
Operating Temperature Range	-55°C to +150°C
Lead Temperature (Soldering, 10sec)	+300°C

	One Side	Both Sides
Power Dissipation	367mW	500mW
Derate above 25°C	3.0mW/°C	4.0mW/°C

NOTE: Stresses above those listed under "Absolute Maximum Ratings" may cause permanent damage to the device. These are stress ratings only and functional operation of the device at these or any other conditions above those indicated in the operational sections of the specifications is not implied. Exposure to absolute maximum rating conditions for extended periods may affect device reliability.

ORDERING INFORMATION

Part	Package	Temperature Range
2N5911-12	Hermetic TO-99	-55°C to +150°C
X2N5912	Sorted Chips in Carriers	-55°C to +150°C

ELECTRICAL CHARACTERISTICS ($T_A = 25^\circ\text{C}$ unless otherwise specified)

SYMBOL	PARAMETER	MIN	MAX	UNITS	TEST CONDITIONS	
I_{GSS}	Gate Reverse Current		-100	pA	$V_{GS} = -15V, V_{DS} = 0$ $T_A = 150^\circ\text{C}$	
			-250	nA		
BV_{GSS}	Gate Reverse Breakdown Voltage	-25			$I_G = -1\mu A, V_{DS} = 0$	
$V_{GS(off)}$	Gate-Source Cutoff Voltage	-1	-5	V	$V_{DS} = 10V, I_D = 1nA$	
V_{GS}	Gate-Source Voltage	-0.3	-4		$V_{DG} = 10V, I_D = 5mA$ $T_A = 150^\circ\text{C}$	
I_G	Gate Operating Current		-100	pA		
			-100	nA		
I_{DSS}	Saturation Drain Current (Pulsewidth 300 μ s, duty cycle \leq 3%)	7	40	mA	$V_{DS} = 10V, V_{GS} = 0V$	
g_{fs}	Common-Source Forward Transconductance	5000	10,000	μ S	$V_{DG} = 10V, I_D = 5mA$	
g_{fs}	Common-Source Forward Transconductance (Note 1)	5000	10,000			f = 1kHz
g_{os}	Common-Source Output Conductance		100			f = 100MHz
g_{oss}	Common-Source Output Conductance (Note 1)		150			f = 1kHz
C_{iss}	Common-Source Input Capacitance (Note 1)		5	pF	f = 100MHz	
C_{rss}	Common-Source Reverse Transfer Capacitance (Note 1)		1.2		f = 1MHz	
\bar{e}_n	Equivalent Short Circuit Input Noise Voltage (Note 1)		20	$\frac{nV}{\sqrt{Hz}}$	f = 10kHz	
NF	Spot Noise Figure (Note 1)		1	dB	f = 10kHz $R_G = 100k\Omega$	

ELECTRICAL CHARACTERISTICS (Continued) ($T_A = 25^\circ\text{C}$ unless otherwise specified)

SYMBOL	PARAMETER	2N5911		2N5912		UNITS	TEST CONDITIONS	
		MIN	MAX	MIN	MAX			
$ I_{G1} - I_{G2} $	Differential Gate Current		20		20	nA	$V_{DG} = 10\text{V}$, $I_D = 5\text{mA}$	$T_A = 125^\circ\text{C}$
$\frac{I_{DSS1}}{I_{DSS2}}$	Saturation Drain Current Ratio	0.95	1	0.95	1		$V_{DS} = 10\text{V}$, $V_{GS} = 0$ (Pulsewidth $300\mu\text{A}$, duty cycle $\leq 3\%$)	
$ V_{GS1} - V_{GS2} $	Differential Gate-Source Voltage		10		15	mV	$V_{DG} = 10\text{V}$, $I_D = 5\text{mA}$	
$\frac{\Delta V_{GS1} - V_{GS2} }{\Delta T}$	Gate-Source Voltage Differential Drift (Measured at end points, T_A and T_B)		20		40	$\mu\text{V}/^\circ\text{C}$		$T_A = 25^\circ\text{C}$ $T_B = 125^\circ\text{C}$
			20		40			$T_A = -55^\circ\text{C}$ $T_B = 25^\circ\text{C}$
$\frac{g_{fs1}}{g_{fs2}}$	Transconductance Ratio	0.95	1	0.95	1			$f = 1\text{kHz}$

NOTE 1: For design reference only, not 100% tested.