

OM5324SA/RA/DA  
OM5325SA/RA/DA

# HERMETIC JEDEC TO-254AA HIGH EFFICIENCY, SOFT RECOVERY CENTER-TAP RECTIFIER

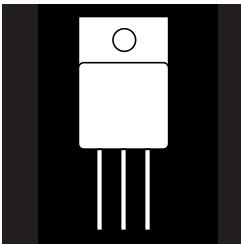

**24 Amp, 800 & 1000 Volts, 50 nsec trr**

## FEATURES

- Small Size
- Ultra Fast Recovery
- Soft Recovery Behavior
- Extremely Low Losses At High Switching Speeds
- Low  $I_{RM}$  Rating
- Hermetic And Isolated Package
- Ceramic Feedthroughs Available
- Available Screened To MIL-S-19500, TX, TXV And S Levels

## DESCRIPTION

These soft recovery, high speed rectifiers are ideally suited for high performance in high voltage switching applications. The performance of these rectifiers minimize losses in power conversion and motor control circuits complementing the switching character of power MOSFETs, IGBTs, and bipolar transistors.

## ABSOLUTE MAXIMUM RATINGS (Per Leg) $T_C = 25^\circ\text{C}$

|   |                 |
|---|-----------------|
| Peak Inverse Voltage.....   | 800 & 1000 V    |
| Maximum Average D.C. Output Current @ $T_C = 100^\circ\text{C}$ ..... | 12 A            |
| Surge Current (Non-Repetitive 8.3 nsec) .....                         | 70 A            |
| Thermal Resistance, Junction-To-Case.....                             | 2.0° C/W        |
| Operating and Storage Temperature Range.....                          | -55°C to +150°C |

## SCHEMATICS

3.2

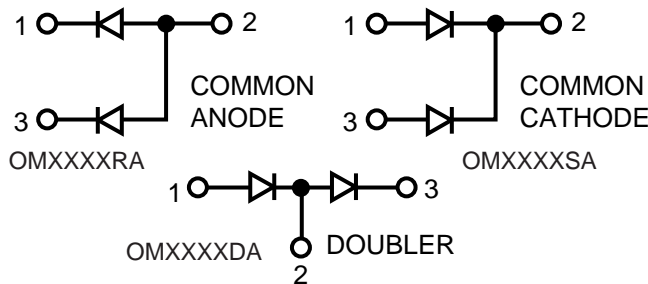

Common cathode is standard. Contact factory for performance characteristics for common anode and doubler.  
Standard products are supplied with glass feedthroughs.  
For ceramic feedthroughs, add letter "C" to part number. Example: OMXXXXCSA.  
Z-Tab package also available.

**ELECTRICAL CHARACTERISTICS (Per Leg)**

| Type     | PIV  | Maximum Forward Voltage @ 12 A |                         | Maximum Reverse Current @ .8x PIV |                         | Maximum Reverse Recovery Time |
|----------|------|--------------------------------|-------------------------|-----------------------------------|-------------------------|-------------------------------|
|          |      | T <sub>J</sub> = 25° C         | T <sub>J</sub> = 150° C | T <sub>J</sub> = 25° C            | T <sub>J</sub> = 125° C |                               |
| OM5324XX | 800  | 2.9 V                          | 2.7 V                   | 150 μA                            | 4 mA                    | 50                            |
| OM5325XX | 1000 |                                |                         |                                   |                         |                               |

**TURN-OFF CHARACTERISTICS**

| Symbols         | Test Conditions   | Min. | Typ. | Max. | Units |
|-----------------|---|------|------|------|-------|
| T <sub>rr</sub> | I <sub>F</sub> = 0.5 A; I <sub>R</sub> = 1 A; T <sub>J</sub> = 25°C<br>I <sub>F</sub> = 1 A; di/dt = -15 A/μs; V <sub>R</sub> = 30 V; T <sub>J</sub> = 25°C | -    | -    | 50   | ns    |
| I <sub>RM</sub> | V <sub>R</sub> = 540 V; I <sub>F</sub> = 12 A<br>L = .05 μH; T <sub>J</sub> = 100°C; di <sub>F</sub> /dt = -100 A/μs  | -    | 6.5  | 7.2  | A     |

**DEFINITION OF TURN-OFF CHARACTERISTICS**

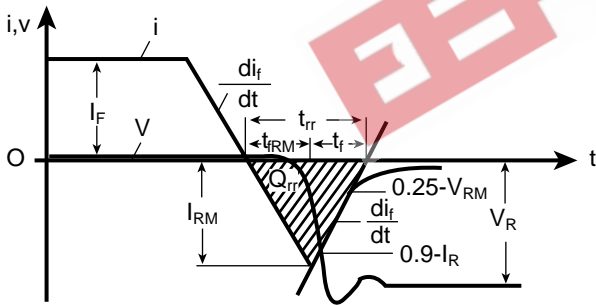

**MECHANICAL OUTLINE WITH PIN CONNECTION**

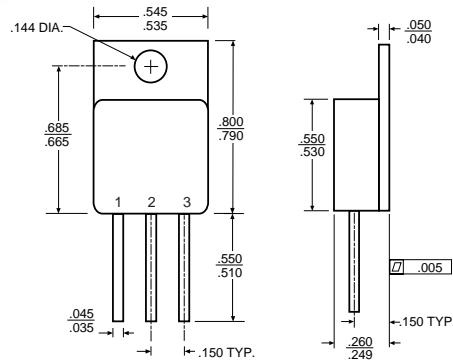

3.2

**TYPICAL REVERSE CURRENT**

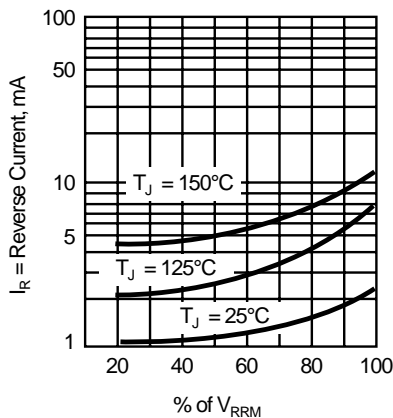

**TYPICAL FORWARD VOLTAGE**

