

OM7608SC OM7610SC  
OM7609SC

## ISOLATED HERMETIC TO-258AA FIXED VOLTAGE REGULATORS

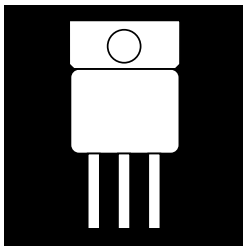

Three Terminal, Fixed Voltage, 3.0 Amp Precision Negative Regulators In Hermetic JEDEC TO-258AA Package

### FEATURES

- Isolated Hermetic Package, JEDEC TO-258AA Outline
- Output Voltages: -5V, -12V And -15V
- Output Voltages Set Internally To  $\pm 2\%$  ( $\pm 1\%$  Available)
- Built-In Thermal Overload Protection
- Short Circuit Current Limiting
- Product Is Available Screened To MIL-STD-883

### DESCRIPTION

These three terminal negative regulators are supplied in a hermetically sealed metal package whose outline is similar to the industry standard TO-247 plastic package. All protective features are designed into the circuit, including thermal shutdown, current limiting and safe-area control. With heat sinking, they can deliver over 3.0 amps of output current. These units feature  $\pm 2\%$  initial voltage tolerance with  $\pm 1\%$  available on request.

### ABSOLUTE MAXIMUM RATINGS @ 25°C

Input Voltage .....	-35V
Operating Junction Temperature Range .....	-55°C to +150°C
Storage Temperature Range .....	-65° to +150°C
Typical Power/Thermal Characteristics:	
Rated Power @ 25°C	
$T_C$ .....	25W
$T_A$ .....	3W
Thermal Resistance	
$\theta_{JC}$ .....	3.5°C/W
$\theta_{JA}$ .....	42°C/W

3.3

**Note:** For  $\pm 1\%$  device. add letter "A" in front of part number (e.g. OMA 7608SC).

## OM7608SC - OM7610SC

### ELECTRICAL CHARACTERISTICS: -5 VOLT OUTPUT (OM7608SC) $T_J = -55\text{ C to } +125\text{ C}$

Parameter	Test Conditions	Min.	Typ.	Max.	Units
$V_{OUT}$	$T_J = 25^\circ\text{C}$ , $V_{IN} = 10\text{ V}$ , $I_O = 5.0\text{ mA}$	-4.90	-5.00	-5.10	V
	8.0 V $V_{IN}$ 35 V, 5 mA $I_O$ 3 A; P 25 W	-4.86	-5.00	-5.14	
Line Regulation (Note 1)	8.0 V $V_{IN}$ 35 V, $T_J = 25^\circ\text{C}$	-	10	25	mV
Load Regulation (Note 1)	5.0 mA $I_O$ 3.0 A, $T_J = 25^\circ\text{C}$	-	20	75	mV
Thermal Regulation	$T_A = 25^\circ\text{C}$ , 20 mS Pulse	-	.002	.01	%/W
Ripple Rejection	$f = 120\text{ Hz}$ ; $V_{OUT} = 5.0\text{ V}$	-	66	-	dB
Minimum Load Current	$V_{IN} = 35\text{ V}$	-	-	15	mA
Current Limit	$V_{IN} = -13\text{ V}$	3	4.3	-	A
Temperature Stability	$-55^\circ\text{C}$ $T$ $+150^\circ\text{C}$	-	-	2.0	%
RMS Output Noise (% of $V_{OUT}$ )	$T_A = 25^\circ\text{C}$ , 10 Hz $f$ 10 kHz	-	.005	-	%

**Note 1:** Regulation is measured at a constant  $T_J$ . Changes in output due to heating must be taken into account separately. Pulse testing with low duty cycle is used.

### ELECTRICAL CHARACTERISTICS: -12 VOLT OUTPUT (OM7609SC) $T_J = -55\text{ C to } +125\text{ C}$

Parameter	Test Conditions	Min.	Typ.	Max.	Units
$V_{OUT}$	$T_J = 25^\circ\text{C}$ , $V_{IN} = 15\text{ V}$ , $I_O = 10\text{ mA}$	-11.76	-12.00	-12.24	V
	15 V $V_{IN}$ 35 V, 5 mA $I_O$ 3 A; P 25 W	-11.66	-12.06	-12.33	
Line Regulation (Note 1)	15 V $V_{IN}$ 35 V, $T_J = 25^\circ\text{C}$	-	10	60	mV
Load Regulation (Note 1)	5 mA $I_O$ 3.0 A, $T_J = 25^\circ\text{C}$	-	40	90	mV
Thermal Regulation	$T_A = 25^\circ\text{C}$ , 20 mS Pulse	-	.002	.02	%/W
Ripple Rejection	$f = 120\text{ Hz}$ ; $V_{OUT} = 12\text{ V}$	-	66	-	dB
Minimum Load Current	$V_{IN} = 35\text{ V}$	-	-	15	mA
Current Limit	$V_{IN} = -20\text{ V}$	3	4.3	-	A
Temperature Stability	$-55^\circ\text{C}$ $T$ $+150^\circ\text{C}$	-	-	2.0	%
RMS Output Noise (% of $V_{OUT}$ )	$T_A = 25^\circ\text{C}$ , 10 Hz $f$ 10 kHz	-	.005	-	%

**Note 1:** Regulation is measured at a constant  $T_J$ . Changes in output due to heating must be taken into account separately. Pulse testing with low duty cycle is used.

## OM7608SC - OM7610SC

### ELECTRICAL CHARACTERISTICS: -15 Volt Output (OM7610SC) $T_J = -55\text{ C to } +125\text{ C}$

Parameter	Test Conditions	Min.	Typ.	Max.	Units
$V_{OUT}$	$T_J = 25^\circ\text{C}$ , $V_{IN} = 23\text{ V}$ , $I_O = 5\text{ mA}$	-14.70	-15.00	-15.30	V
	18 V $V_{IN}$ 35 V, 5 mA $I_O$ 3 A; P 25 W	-14.58	-15.00	-15.42	
Line Regulation (Note 1)	18 V $V_{IN}$ 35 V, $T_J = 25^\circ\text{C}$	-	10	75	mV
Load Regulation (Note 1)	5 mA $I_O$ 3.0 A, $T_J = 25^\circ\text{C}$	-	50	100	mV
Thermal Regulation	$T_A = 25^\circ\text{C}$ , 20 mS Pulse	-	.002	.02	%/W
Ripple Rejection	$f = 120\text{ Hz}$ ; $V_{OUT} = 15\text{ V}$	-	66	-	dB
Minimum Load Current	$V_{IN} = 35\text{ V}$	-	-	15	mA
Current Limit	$V_{IN} = -23\text{ V}$	3	4.3	-	A
Temperature Stability	$-55^\circ\text{C}$ $T$ $+150^\circ\text{C}$	-	-	2.0	%
RMS Output Noise (% of $V_{OUT}$ )	$T_A = 25^\circ\text{C}$ , 10 Hz $f$ 10 kHz	-	.005	-	%

**Note 1:** Regulation is measured at a constant  $T_J$ . Changes in output due to heating must be taken into account separately. Pulse testing with low duty cycle is used.

### Current Limit

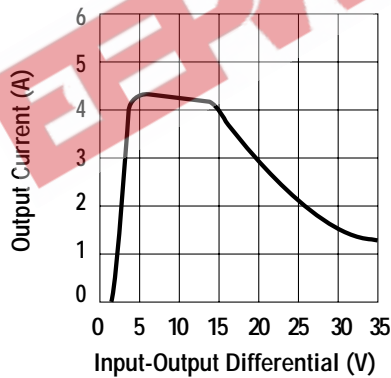

### Dropout Voltage

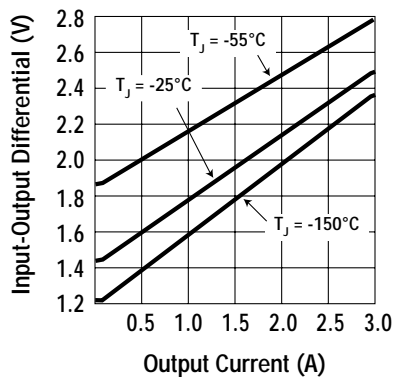

### Ripple Rejection

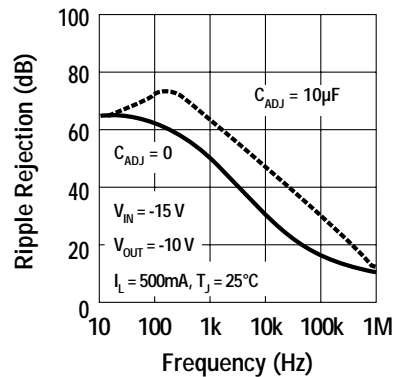

3.3

## TYPICAL APPLICATIONS

### 3 Amp Regulator

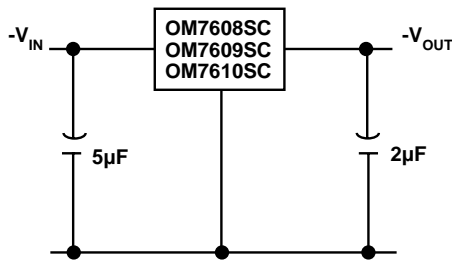

### Dual Regulator

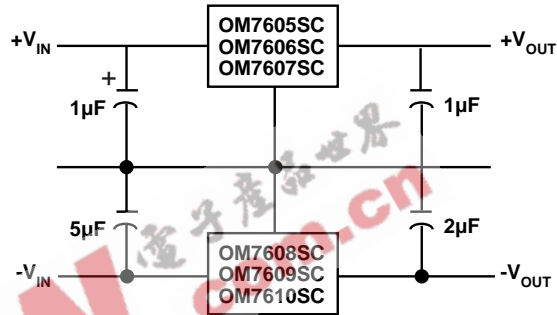

## MECHANICAL OUTLINE

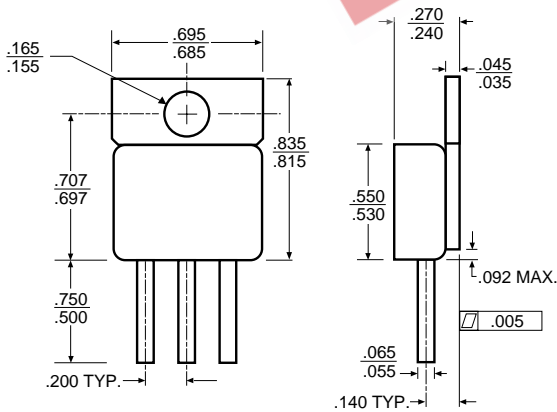

## PIN CONNECTION

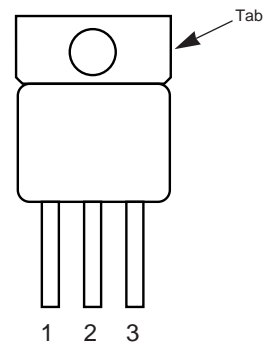

Front View  
 Pin 1: Ground  
 Pin 2: Input  
 Pin 3: Output  
 Tab: Isolated

### NOTES:

- Case is metal/hermetically sealed
- Isolated Tab
- This device is also available in a TO-257AA package. Call the factory for test conditions and limits.