

**OC-X87XXXXX Series**

Micro-miniature OCXO

**Features**

- Low Cost DIL 14 package
- High Vacuum Sealed Crystal
- Low Power Consumption (500 mW)
- Fast Warm-up Time (2 minutes)
- Stratum3 or better Stability
- Low Aging < 3 ppm over life
- Very Low Phase Noise (-160dBc/Hz TYP)
- HCMOS/TTL or Sine-Wave output
- 8 MHz to 160 MHz Frequencies Available
- Voltage Control Optional

**Applications**

- Telecommunications
- Data Communications
- Instrumentation

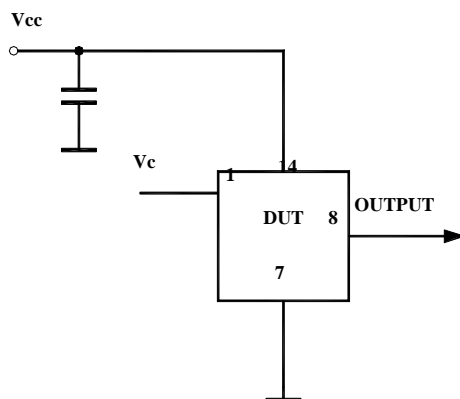
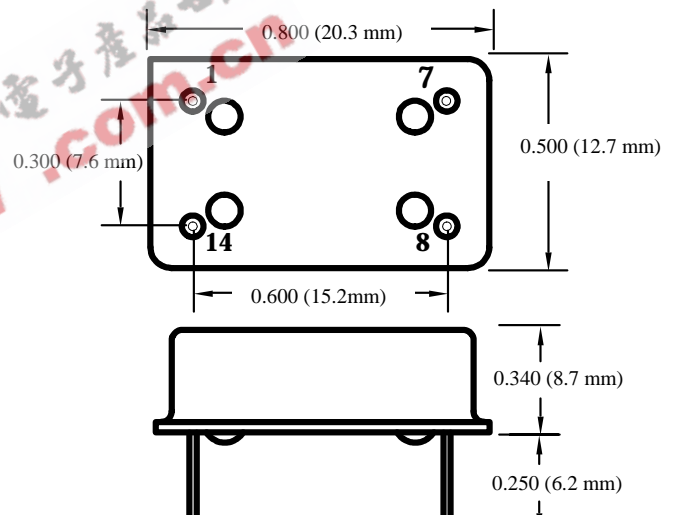

## OC-X87XXXXX Series

Micro-miniature OCXO

### Specifications:

Parameter	Symb	Condition	Min	Typ	Max	Unit	Note
<i>Absolute Maximum Ratings</i>							
<b>Input Break Down Voltage</b>	V <sub>cc</sub>		-0.5		5.5	V	3.3V or 5V V <sub>cc</sub> 12 V V <sub>cc</sub>
<b>Storage temper.</b>	T <sub>s</sub>		-40		85	°C	
<b>Control Voltage</b>	V <sub>c</sub>		-1		6	V	

### Electrical

<b>Frequency</b>	F		8	10.000	160	MHz	1*	All parameters for 10 MHz
<b>Frequency stability</b>	ΔF/F	vs. Temp.		±100	±280	ppb	See chart below	
		vs. Supply		10	50	ppb/V		
<b>Aging</b>		per day first year 15 years		5E-9 3E-7			after 30 days	
<b>Allan Variance</b>		.1s to 100s		5E-11				
<b>Calibration</b>		No voltage control		± 0.5	± 2	ppm		
<b>V<sub>cc</sub> sensitivity</b>				5E-8/V				
<b>Load sensitivity</b>		For 10% change			5E-8			
<b>SSB Phase Noise</b>		10 Hz		-100		dBc/Hz	2*	
		100 Hz		-130				
		1 KHz		-145				
		>10 KHz		-160				
<b>Retrace</b>		After 30 minutes			±100	ppb		
<b>G-sensitivity</b>		worst direction			±2.0	ppb/G		
<b>Input Voltage</b>	V <sub>cc</sub>		4.75	5.0	5.25	V	See chart below	
			3.15	3.3	3.45			
			11.4	12.0	12.6			
<b>Power consumption</b>	P	steady state, 25°C		0.5	0.7	W	Upper operating temperature < 70°C, add 20% for UOT 85°C	
		steady state, -30°C start-up						1.5 2.5
<b>Load</b>		10KOhm//15pF Internally AC coupled 50 Ohm					CMOS Output Sine-wave output	
<b>Warm-up time</b>	τ	to 0.3 ppm accuracy		2	3	min		
<b>Sub-Harmonics</b>				-50	-40	dBc	At higher F 1*	
<b>Output Waveform</b>		3.3V HCMOS/TTL compatible, 4 ns Tr/Tf, 40/60% duty cycle Sine-wave, + 7 dBm ±3 dBm into 50 Ohm, -30 dBc harmonics					See chart below	
<b>Control voltage</b>	V <sub>c</sub>		0		4.0	V		
<b>Pull range</b>		from nominal F	±5	±10		ppm	Customer specified	
<b>Deviation slope</b>		Monotonic, posit		5		ppm/V	Customer specified	
<b>Setability</b>	V <sub>c0</sub>	@25°C, F <sub>nom.</sub>	1.0	2.0	3.0	V	5V/3.3 supply	

### Environmental and Mechanical

<b>Operating temp. range</b>	-30°C to 70°C Standard, Other options – see chart below
<b>Mechanical Shock</b>	Per MIL-STD-202, 30G, 11ms
<b>Vibration</b>	Per MIL-STD-202, 5G to 2000 Hz
<b>Soldering Conditions</b>	Leads Temperature 260°C, for 10s, Max
<b>Hermetic Seal</b>	Leak rate less than 1x10 <sup>-8</sup> atm.ccm/s of helium

### Electrical Connections

<b>Pin Out</b>	Pin 1- V <sub>c</sub> ; Pin 7- Case, GND; Pin8 – Output; Pin 14 - V <sub>cc</sub>
----------------	---

**OC-X87XXXXX Series**  
Micro-miniature OCXO

**Creating a Part Number**



Not all combinations are available. Consult Factory.

Notes:

1\* Higher frequencies can be achieved either by using higher frequency crystals or by low noise analog harmonic multiplication. Both methods have advantages and drawbacks. If lowest possible phase noise on the noise floor is most important – high frequency crystal will be used. If phase noise close to the carrier and aging are more important – multiplication will be used. Please consult factory for your specific requirement.

2\* Phase noise deteriorates with frequencies going higher. If analog multiplication is used to achieve higher frequency the phase noise roughly follows the formula of additional 20LogN, where N is a multiplication factor across entire frequency offset range. If higher frequency is achieved by using higher frequency crystal phase noise close to the carrier deteriorates due to the lower Q of the crystal and is usually worse, compared to multiplied solution. On the noise floor, however it remains more or less the same.