

OF-X8HXXXXX Series
Precision SC-cut OCXO in 25x22 mm Low Profile SMD Package

Product Data Sheet

Features

- SC-cut crystal
- High Stability (up to $\pm 5 \times 10^{-9}$)
- Low Aging (5×10^{-10} /day, 5×10^{-8} /year)
- Low Phase Noise (-160 dBc/Hz, TYP, floor)
- Sine Wave or HCMOS/TTL output
- 4.8 MHz to 160 MHz Frequencies Available

Applications

- Telecommunication Systems
- Data Communications
- GPS
- Instrumentation

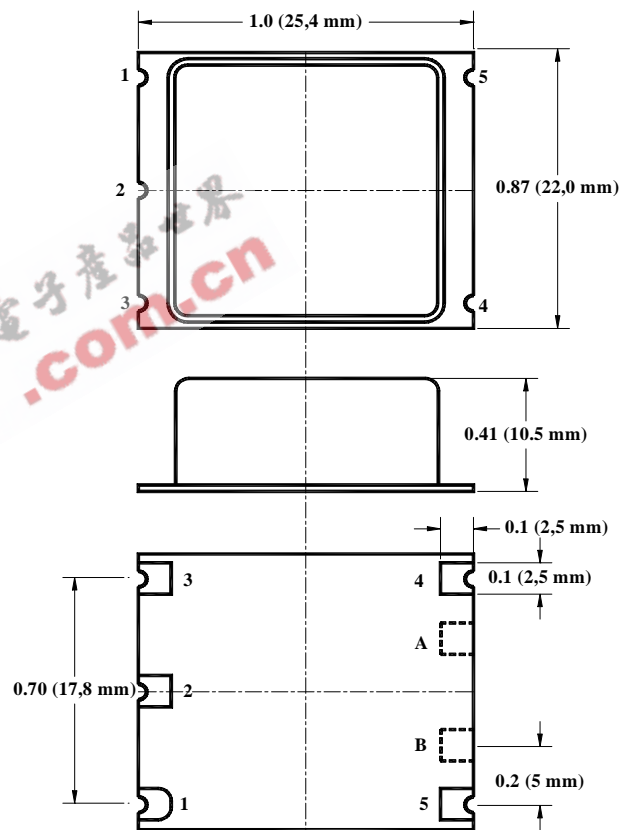

OF-X8HXXXXX Series

Parameter	Symb	Condition	Min	Typ	Max	Unit	Note
Absolute Maximum Ratings							
Input Break Down Voltage	V _{cc}		-0.5		13.0	V	
Storage temper.	T _s		-40		85	°C	
Control Voltage	V _c		-1		9	V	

Electrical

Frequency	F		4.8	10.000	160	MHz	1*	All parameters for 10 MHz
Frequency stability	ΔF/F	vs. Temp.		±10		ppb	See chart below	
		vs. Supply		1	2	ppb/V		
Aging	ΔF/F	per day per year		5E-10 1E-7			after 30 days 5E-8 available2*	
After Reflow	ΔF/F	Per profile below		0.1	0.2	ppm	Each time	
Allan Variance		.1s to 10s		1E-11				
SSB Phase Noise		1Hz		-90		dBc/Hz	3*	
		10 Hz		-120				
		100 Hz		-150				
		1 KHz		-153				
		10 KHz		-160				
Retrace		After 30 minutes			±10	ppb		
G-sensitivity		worst direction			±1.0	ppb/G		
Input Voltage	V _{cc}		4.75 3.15 11.4	5.0 3.3 12.0	5.25 3.45 12.6	V	See chart below to specify	
Power consumption	P	steady state, 25°C steady state, -30°C start-up @ -30°C		0.8 1.5 2.5	1.2 3.2	W	Standard Operating Temperature, for Op Temp. 85 °C ad 20%	
Spectral Purity		Subharmonics		-50	-45	dBc	At Higher Frequencies	
		Spurious			-80			
		Harmonics/Sine		-35	-30			
Load		10KOhm/15pF (HCMOS/TTL), 50 Ohm (Sinewave)						
Warm-up time	τ	to 0.1ppm accuracy		3	5	minutes	3 min. at 12V	
Output Waveform		3.3V HCMOS/TTL compatible or Sinewave				(+7±3) dBm	-25dBm Harmonics at sine	
Control voltage	V _c		0		4.0	V		
Pull range		from nominal F	±0.5	±1		ppm		
Deviation slope		Monotonic, posit		0.4		ppm/V		
Setability	V _{c0}	@25°C, F _{nom} .	1.0	2.0	3.0	V		

Environmental and Mechanical

Operating temp. range	-30°C to 70°C Standard, Other options – see chart below
Mechanical Shock	Per MIL-STD-202, 30G, 11ms
Vibration	Per MIL-STD-202, 5G to 2000 Hz
Soldering Conditions	See MAX reflow profile below

Electrical Connections

Pin Out	Pin #1-V _c ; Pin#2 – V _{ref} ; Pin #3 – V _{cc} ; Pin #4- Output ; Pin #5- GND; 4*
---------	--

Notes: 1* Higher frequencies can be achieved either by using higher frequency crystals or by low noise analog harmonic multiplication. Both methods have advantages and drawbacks. If lowest possible phase noise on the noise floor is most important – high frequency crystal will be used. If phase noise close to the carrier and aging are more important – multiplication will be used. Please consult factory for your specific requirement.

2* Aging rate is usually proportional to the operating frequency, unless higher frequency is achieved by multiplication. Keep it in mind while specifying aging.

3* Phase noise deteriorates with frequencies going higher. If analog multiplication is used to achieve higher frequency the phase noise roughly follows the formula of additional 20LogN, where N is a multiplication factor across entire frequency offset range. If higher frequency is achieved by using higher frequency crystal phase noise close to the carrier deteriorates due to the lower Q of the crystal and is usually worse, compared to multiplied solution. On the noise floor, however it remains more or less the same. This design usually starts utilizing multiplication techniques in the range of 25 MHz to 35 MHz.

4* Pads "A" and "B" may or may not appear on the actual package. They can be used when additional functions i.e. "Oven Ready" alarm or "Tristate" are specified. Please consult factory.

OF-X8HXXXXX Series

Creating a Part Number

OF - X 8H X XX X X

Package Code
OF 5 pad 25x22mm SMD

Aging

Code	Specification
L	1x10 ⁻⁹ /Day
S	5x10 ⁻¹⁰ /Day
P	2x10 ⁻¹⁰ /Day

Supply Voltage

Code	Specification
0	5V ± 5%
A	3.3V ± 5%
F	12V 5%

Temperature Stability

Code	Specification
17	1x10 ⁻⁷
58	5x10 ⁻⁸
28	2x10 ⁻⁸
18	1x10 ⁻⁸
59	5x10 ⁻⁹
YZ	Yx10 ^{-Z}

Temperature Range

Code	Specification
A	0°C to 50°C
B	-10°C to 60°C
C	0°C to 70°C
D	-20°C to 70°C
E	-30°C to 70°C
F	-40°C to 80°C

Output

Code	Specification
T	TTL
S	Sinewave

Not all combinations are available. Consult Factory.

MAX Reflow Profile

