

OM5328SC/RC/DC
OM5329SC/RC/DC

HERMETIC JEDEC TO-258AA HIGH EFFICIENCY, SOFT RECOVERY CENTER-TAP RECTIFIER

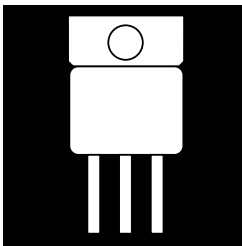

60 Amp, 800 & 1000 Volts, 50 nsec trr

FEATURES

- Small Size
- Ultra Fast Recovery
- Soft Recovery Behavior
- Extremely Low Losses At High Switching Speeds
- Low I_{RM} Rating
- Hermetic And Isolated Package
- Available Screened To MIL-S-19500, TX, TXV And S-Levels

DESCRIPTION

These soft recovery, high speed rectifiers are ideally suited for high performances in high voltage switching applications. The performance of these rectifiers minimize losses in power conversion and motor control circuits complementing the switching character of power MOSFETs, IGBTs, and bipolar transistors.

ABSOLUTE MAXIMUM RATINGS (Per Leg) $T_C = 25^\circ\text{C}$

Peak Inverse Voltage.....	800 & 1000 V
Maximum Average D.C. Output Current @ $T_C = 100^\circ\text{C}$	30 A
Surge Current (Non-Repetitive 8.3 nsec)	200 A
Thermal Resistance, Junction-To-Case	1.13° C/W
Operating and Storage Temperature Range	-55° C to +150° C

SCHEMATICS

3.2

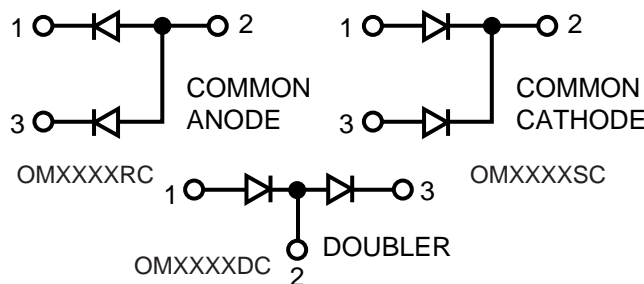

Common cathode is standard. Contact the factory for performance characteristics for common anode and doubler.
Z-Tab package also available.

ELECTRICAL CHARACTERISTICS (Per Leg)

Type	PIV	Maximum Forward Voltage @ 30 A		Maximum Reverse Current @ .8x PIV		Maximum Reverse Recovery Time
		T _J = 25° C	T _J = 150° C	T _J = 25° C	T _J = 125° C	
OM5328XX	800	2.4 V	2.0 V	250 μA	7 mA	50
OM5329XX	1000					

TURN-OFF CHARACTERISTICS

Symbols	Test Conditions	Min.	Typ.	Max.	Units
T _{rr}	I _F = 0.5 A; I _R = 1 A; T _J = 25°C I _F = 1 A; di _F /dt = -15 A/μs; V _R = 30 V; T _J = 25°C	-	-	50	ns
I _{RM}	V _R = 540 V; I _F = 30 A L = .05 μH; T _J = 100°C; di _F /dt = -240 A/μs	-	16	18	A

DEFINITION OF TURN-OFF CHARACTERISTICS

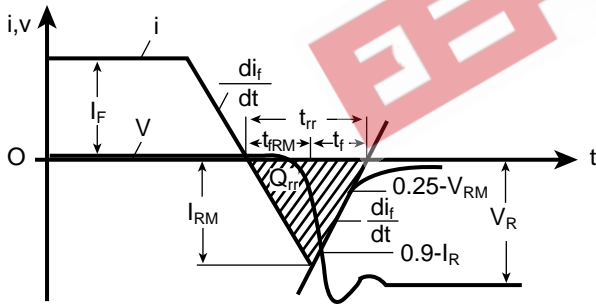

MECHANICAL OUTLINE WITH PIN CONNECTION

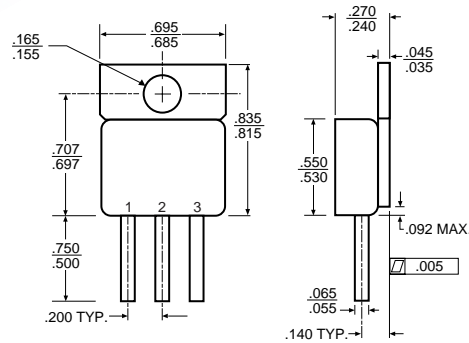

3.2

TYPICAL REVERSE CURRENT

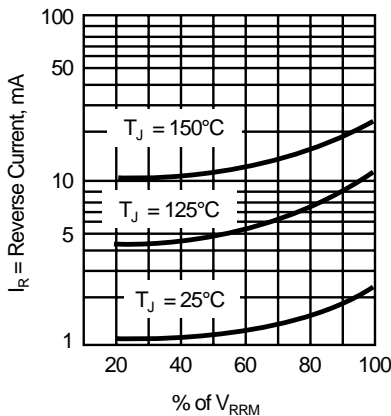

TYPICAL FORWARD VOLTAGE

