

FEATURES

- High Slew Rate 10V/ μ s Min
- Fast Settling Time 0.9 μ s to 0.1% Typ
- Low Input Offset Voltage Drift 10 μ V/ $^{\circ}$ C Max
- Wide Bandwidth 3.5MHz Min
- Temperature-Compensated Input Bias Currents
- Guaranteed Input Bias Current 18nA Max (125 $^{\circ}$ C)
- Bias Current Specified Warmed-Up Over Temperature
- Low Input Noise Current 0.01pA/ $\sqrt{\text{Hz}}$ Typ
- High Common-Mode Rejection Ratio 86dB Min
- Pin Compatible With Standard Dual Pinouts
- 125 $^{\circ}$ C Temperature Tested DICE
- Models With MIL-STD-883 Class B Processing Available
- Available in Die Form

ORDERING INFORMATION †

$T_A = 25^{\circ}\text{C}$ $V_{OS} \text{ MAX}$ (mV)	PACKAGE			OPERATING TEMPERATURE RANGE	
	TO-99	CERDIP 8-PIN	PLASTIC 8-PIN		LCC 20-CONTACT
1.0	OP215AJ*	OP215AZ*	-	-	MIL
1.0	OP215EJ	OP215EZ	OP215EP	-	COM
2.0	OP215BJ/883	OP215BZ/883	-	OP215BRC/883	MIL
2.0	OP215FJ	OP215FZ	OP215FP	-	COM
4.0	OP215CJ/883	OP215CZ/883	-	-	MIL
6.0	-	OP215GZ	OP215GP	-	XIND
6.0	-	-	OP215GS	-	XIND

* For devices processed in total compliance to MIL-STD-883, add /883 after part number. Consult factory for 883 data sheet.

† Burn-in is available on commercial and industrial temperature range parts in CerDIP, plastic DIP, and TO-can packages.

GENERAL DESCRIPTION

The OP-215 offers the proven JFET-input performance advantages of high speed and low input bias current with the

tracking and convenience advantages of a dual op-amp configuration.

Low input offset voltages, low input currents, and low drift are featured in these high-speed amplifiers.

On-chip zener-zap trimming is used to achieve low V_{OS} while a bias-current compensation scheme gives a low input bias current at elevated temperatures. Thus the OP-215 features an input bias current of 18nA at 125 $^{\circ}$ C ambient (not junction) temperature which greatly extends the application usefulness of this device.

Applications include high-speed amplifiers for current output DACs, active filters, sample-and-hold buffers, and photocell

PIN CONNECTIONS

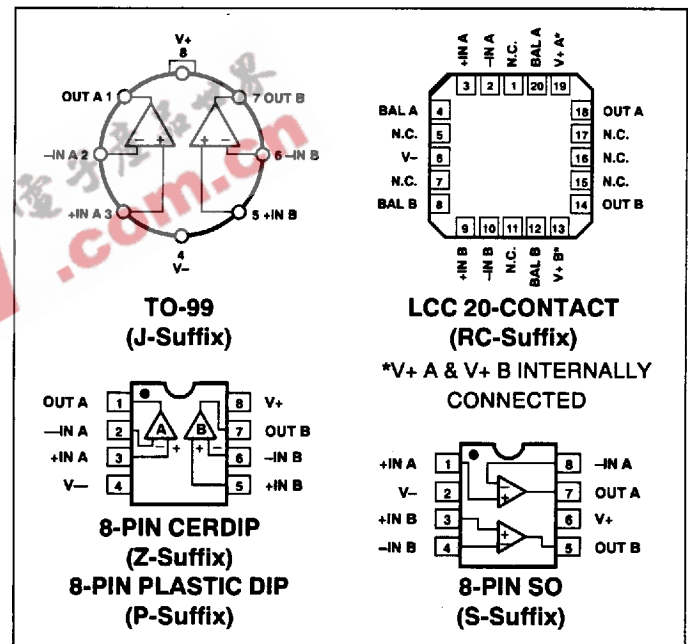

SIMPLIFIED SCHEMATIC (1/2 OP-215)

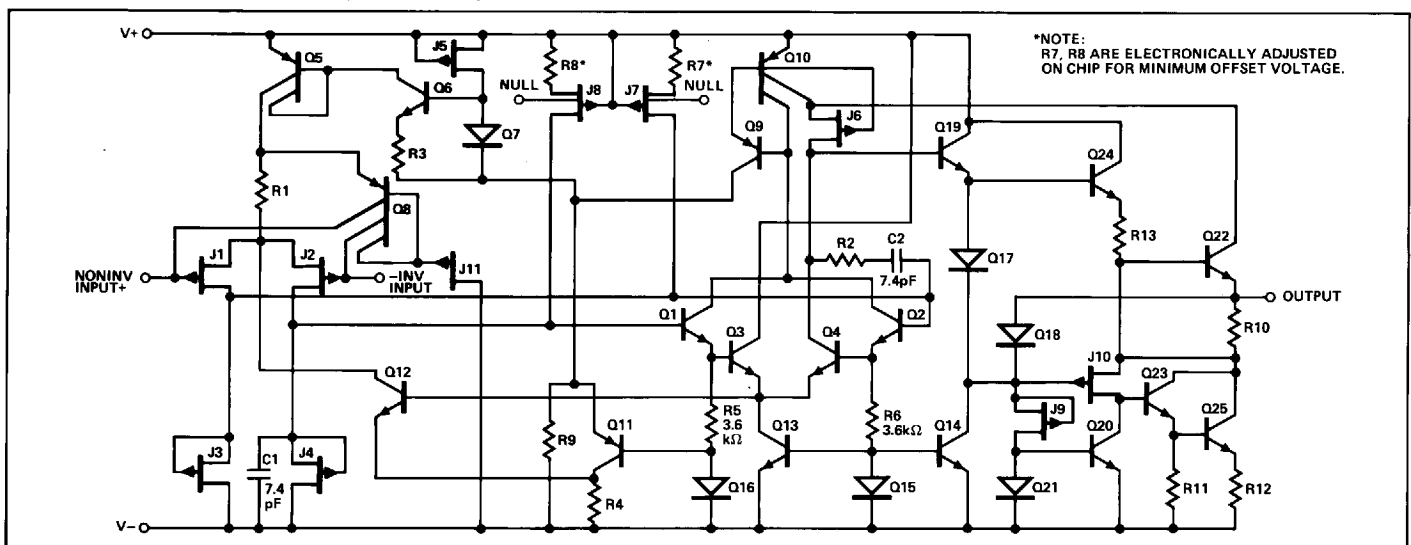

OP-215

GENERAL DESCRIPTION *Continued*

amplifiers. For additional precision JFET op amps, see the OP-15/16/17 data sheet.

ABSOLUTE MAXIMUM RATINGS (Note 1)

Supply Voltage

OP-215A, OP-215B, OP-215E, OP-215F (All DICE Except GR)	±22V
OP-215C, OP-215G (GR DICE Only)	±18V

Operating Temperature Range

OP-215A, OP-215B, OP-215C	-55°C to +125°C
OP-215E, OP-215F	0°C to +70°C
OP-215G	-40°C to +85°C

Maximum Junction Temperature (T_J)

Differential Input Voltage

OP-215A, OP-215B, (All DICE Except GR)	±40V
OP-215E, OP-215F, (All DICE Except GR)	±40V
OP-215C, OP-215G, (GR DICE Only)	±30V

Input Voltage

OP-215A, OP-215B, (All DICE Except GR)	±20V
OP-215E, OP-215F, (All DICE Except GR)	±20V

OP-215C, OP-215G, (GR DICE Only)..... ±16V
(Unless otherwise specified, the absolute maximum negative input voltage is equal to one volt more positive than the negative power supply voltage.)

Output Short-Circuit Duration Indefinite
Storage Temperature Range -65°C to +150°C
Lead Temperature (Soldering, 60 sec) 300°C
Junction Temperature (T_J)..... -65°C to +150°C

PACKAGE TYPE	θ _{JA} (NOTE 2)	θ _{JC}	UNITS
TO-99 (J)	145	16	°C/W
8-Pin Hermetic DIP (Z)	134	12	°C/W
8-Pin Plastic DIP (P)	96	37	°C/W
20-Contact LCC (RC)	88	33	°C/W
8-Pin SO (S)	150	41	°C/W

NOTES:

1. Absolute maximum ratings apply to both DICE and packaged parts, unless otherwise noted.
2. θ_{JA} is specified for worst case mounting conditions, i.e., θ_{JA} is specified for device in socket for TO, CerDIP, P-DIP, and LCC packages; θ_{JA} is specified for device soldered to printed circuit board for SO package.

ELECTRICAL CHARACTERISTICS at V_S = ±15V, T_A = 25°C, unless otherwise noted.

PARAMETER	SYMBOL	CONDITIONS	OP-215A/E			OP-215B/F			OP-215C/G			UNITS
			MIN	TYP	MAX	MIN	TYP	MAX	MIN	TYP	MAX	
Input Offset Voltage	V _{OS}	R _S = 50Ω 'G' Grade	—	0.2	1.0	—	0.8	2.0	—	2.0	4.0	mV
Input Offset Current	I _{OS}	T _J = 25°C (Note 1) Device Operating	—	3	50	—	3	50	—	3	100	pA
Input Bias Current	I _B	T _J = 25°C (Note 1) Device Operating	—	±15	±100	—	±15	±200	—	±15	±300	pA
Input Resistance	R _{IN}		—	10 ¹²	—	—	10 ¹²	—	—	10 ¹²	—	Ω
Large-Signal Voltage Gain	A _{VO}	R _L ≥ 2kΩ V _O = ±10V	150	500	—	75	220	—	50	200	—	V/mV
Output Voltage Swing	V _O	R _L = 10kΩ R _L = 2kΩ	±12	±13	—	±12	±13	—	±12	±13	—	V
Supply Current	I _{SY}	'G' Grade	—	6.0	8.5	—	6.0	8.5	—	7.0	10.0	mA
Slew Rate	SR	A _{VCL} = +1	10	18	—	7.5	18	—	5	15	—	V/μs
Gain Bandwidth Product	GBW	(Note 3)	3.5	5.7	—	3.5	5.7	—	3.0	5.4	—	MHz
Closed-Loop Bandwidth	CLBW	A _{VCL} = +1	—	13	—	—	13	—	—	12	—	MHz
Settling Time	t _S	to 0.01% to 0.05% (Note 2) to 0.10%	—	2.3	—	—	2.3	—	—	2.4	—	μs
Input Voltage Range	IVR		+10.2	+14.8	—	+10.2	+14.8	—	+10.1	+14.8	—	V
Common-Mode Rejection Ratio	CMRR	V _{CM} = ±IVR A, B, C Grades E, F, G Grades	86	100	—	86	100	—	82	96	—	dB
Power Supply Rejection Ratio	PSRR	V _S = ±10V to ±16V V _S = ±10V to ±15V	—	10	51	—	10	80	—	—	—	μV/V
Input Noise Voltage Density	e _n	f _O = 100Hz f _O = 1000Hz	—	20	—	—	20	—	—	20	—	nV/√Hz
Input Noise Current Density	i _n	f _O = 100Hz f _O = 1000Hz	—	0.01	—	—	0.01	—	—	0.01	—	pA/√Hz
Input Capacitance	C _{IN}		—	3	—	—	3	—	—	3	—	pF

ELECTRICAL CHARACTERISTICS at $V_S = \pm 15V$, $-55^\circ C \leq T_A \leq +125^\circ C$, unless otherwise noted.

PARAMETER	SYMBOL	CONDITIONS	OP-215A			OP-215B			OP-215C			UNITS
			MIN	TYP	MAX	MIN	TYP	MAX	MIN	TYP	MAX	
Input Offset Voltage	V_{OS}	$R_S = 50\Omega$	—	0.5	2.0	—	1.5	3.0	—	3.0	6.0	mV
Average Input Offset Voltage Drift												
Without External Trim	TCV_{OS}	(Note 3)	—	3	10	—	3	10	—	6	—	$\mu V/^\circ C$
With External Trim	TCV_{OSn}	$R_P = 100k\Omega$	—	3	—	—	3	—	—	4	—	
Input Offset Current (Note 1)	I_{OS}	$T_J = +125^\circ C$ $T_A = +125^\circ C$, Device Operating	—	0.8	8	—	0.8	8	—	1.0	12	nA
			—	1.2	14	—	1.2	14	—	1.5	22	
Input Bias Current (Note 1)	I_B	$T_J = +125^\circ C$ $T_A = +125^\circ C$, Device Operating	—	± 1.5	± 10	—	± 1.5	± 10	—	± 1.8	± 15	nA
			—	± 2.2	± 18	—	± 2.2	± 18	—	± 2.7	± 28	
Input Voltage Range	IVR		+10.2 -10.2	+14.6 -11.3	—	+10.2 -10.2	+14.6 -11.3	—	+10.1 -10.1	+14.6 -11.3	—	V
Common-Mode Rejection Ratio	CMRR	$V_{CM} = \pm IVR$	82	97	—	82	97	—	80	93	—	dB
Power Supply Rejection Ratio	PSRR	$V_S = \pm 10V$ to $\pm 16V$ $V_S = \pm 10V$ to $\pm 15V$	—	10	100	—	15	100	—	—	—	$\mu V/V$
			—	—	—	—	—	—	—	23	126	
Large-Signal Voltage Gain	A_{VO}	$R_L \geq 2k\Omega$ $V_O = \pm 10V$	30	110	—	30	110	—	25	100	—	V/mV
Output Voltage Swing	V_O	$R_L \geq 10k\Omega$	± 12	± 13	—	± 12	± 13	—	± 12	± 13	—	V

ELECTRICAL CHARACTERISTICS at $V_S = \pm 15V$, $0^\circ C \leq T_A \leq +70^\circ C$ for E/F Grades, $-40^\circ C \leq T_A \leq +85^\circ C$ for G Grade, unless otherwise noted.

PARAMETER	SYMBOL	CONDITIONS	OP-215E			OP-215F			OP-215G			UNITS
			MIN	TYP	MAX	MIN	TYP	MAX	MIN	TYP	MAX	
Input Offset Voltage	V_{OS}	$R_S = 50\Omega$	—	0.4	1.65	—	1.4	2.65	—	3.5	8.0	mV
Average Input Offset Voltage Drift												
Without External Trim	TCV_{OS}	(Note 3)	—	3	15	—	3	15	—	6	—	$\mu V/^\circ C$
With External Trim	TCV_{OSn}	$R_P = 100k\Omega$	—	3	—	—	3	—	—	4	—	
Input Offset Current (Note 1)	I_{OS}	$T_J = +70^\circ C$ $T_A = +70^\circ C$, Device Operating	—	0.06	0.45	—	0.06	0.45	—	0.08	0.65	nA
			—	0.08	0.80	—	0.08	0.80	—	0.10	1.2	
Input Bias Current (Note 1)	I_B	$T_J = +70^\circ C$ $T_A = +70^\circ C$, Device Operating	—	± 0.12	± 0.70	—	± 0.12	± 0.70	—	± 0.14	± 0.9	nA
			—	± 0.16	± 1.40	—	± 0.16	± 1.40	—	± 0.19	± 1.8	
Input Voltage Range	IVR		+10.2 -10.2	+14.7 -11.4	—	+10.2 -10.2	+14.7 -11.4	—	+10.1 -10.1	+14.7 -11.3	—	V
Common-Mode Rejection Ratio	CMRR	$V_{CM} = \pm IVR$	80	98	—	80	98	—	76	94	—	dB
Power Supply Rejection Ratio	PSRR	$V_S = \pm 10V$ to $\pm 16V$ $V_S = \pm 10V$ to $\pm 15V$	—	13	100	—	13	100	—	—	—	$\mu V/V$
			—	—	—	—	—	—	—	20	159	
Large-Signal Voltage Gain	A_{VO}	$R_L \geq 2k\Omega$ $V_O = \pm 10V$	50	180	—	50	180	—	35	130	—	V/mV
Output Voltage Swing	V_O	$R_L \geq 10k\Omega$	± 12	± 13	—	± 12	± 13	—	± 12	± 13	—	V

NOTES:

- Input bias current is specified for two different conditions. The $T_J = 25^\circ C$ specification is with the junction at ambient temperature; the Device Operating specification is with the device operating in a warmed-up condition at $25^\circ C$ ambient. The warmed-up bias current value is correlated to the junction temperature value via the curves of I_B vs. T_J and I_B vs. T_A . PMI has a bias current compensation circuit which gives improved bias current and bias current over temperature vs. standard JFET input op amps. I_B and I_{OS} are measured at $V_{CM} = 0$.
- Settling time is defined here for a unity gain inverter connection using $2k\Omega$ resistors. It is the time required for the error voltage (the voltage at the inverting input pin on the amplifier) to settle to within a specified percent of its final value from the time a $10V$ step input is applied to the inverter. See settling time test circuit.
- Sample tested.

OP-215

DICE CHARACTERISTICS (125°C TESTED DICE AVAILABLE)

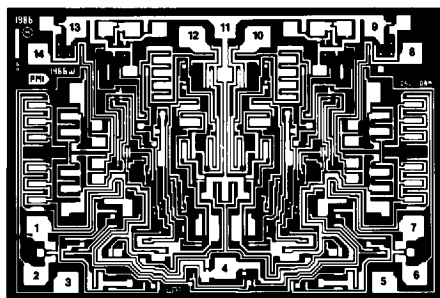

- | | |
|---------------------------|------------------------|
| 1. INVERTING INPUT (A) | 8. NULL (B) |
| 2. NONINVERTING INPUT (A) | 9. V+ |
| 3. NULL (A) | 10. V _O (B) |
| 4. V- | 11. V+ |
| 5. NULL (B) | 12. V _O (A) |
| 6. NONINVERTING INPUT (B) | 13. V+ |
| 7. INVERTING INPUT (B) | 14. NULL (A) |

ALL V+ PADS ARE INTERNALLY CONNECTED.

DIE SIZE 0.110 × 0.075 inch, 8250 sq. mils
(2.79 × 1.91 mm, 5.33 sq. mm)

WAFER TEST LIMITS at $V_S = \pm 15V$, $T_A = 25^\circ C$ for OP-215N, OP-215G and OP-215GR devices; $T_A = 125^\circ C$ for OP-215NT and OP-215GT devices, unless otherwise noted.

PARAMETER	SYMBOL	CONDITIONS	OP-215NT LIMIT	OP-215N LIMIT	OP-215GT LIMIT	OP-215G LIMIT	OP-215GR LIMIT	UNITS
Input Offset Voltage	V_{OS}	$R_S = 50\Omega$	2	1	3	2	6	mV MAX
Input Bias Current	I_B		±18	—	±18	—	—	nA MAX
Input Offset Current	I_{OS}		14	—	14	—	—	nA MAX
Large-Signal Voltage Gain	A_{VO}	$V_O = \pm 10V$, $R_L = 2k\Omega$	30	150	30	75	50	V/mV MIN
Input Voltage Range	IVR		±10.2	±10.2	±10.2	±10.2	±10.1	V MIN
Common-Mode Rejection Ratio	CMRR	$V_{CM} = \pm IVR$	82	86	82	86	82	dB MIN
Power Supply Rejection Ratio	PSRR	$V_S = \pm 10$ to $\pm 16V$ $V_S = \pm 10$ to $\pm 15V$	100	51	100	80	—	μV/V MAX
Output Voltage Swing	V_O	$R_L = 10k\Omega$ $R_L = 2k\Omega$	±12	±12 ±11	±12	±12 ±11	±12 ±11	V MIN
Supply Current	I_{SY}		—	8.5	—	8.5	12.0	mA MAX

NOTES:

For 25°C characteristics of NT & GT devices, see N & G characteristics respectively.

Electrical tests are performed at wafer probe to the limits shown. Due to variations in assembly methods and normal yield loss, yield after packaging is not guaranteed for standard product dice. Consult factory to negotiate specifications based on dice lot qualification through sample lot assembly and testing.

TYPICAL ELECTRICAL CHARACTERISTICS at $V_S = \pm 15V$, $T_A = +25^\circ C$, unless otherwise noted.

PARAMETER	SYMBOL	CONDITIONS	OP-215NT TYPICAL	OP-215N TYPICAL	OP-215GT TYPICAL	OP-215G TYPICAL	OP-215GR TYPICAL	UNITS
Average Input Offset Voltage Drift	TCV_{OS}	Unnulled $R_P = 100k\Omega$	2	2	3	3	4	μV/°C
Average Input Offset Voltage Drift	TCV_{OSn}	Nulled $R_P = 100k\Omega$	0.5	0.5	1	1	2	μV/°C
Input Offset Current	I_{OS}		3	3	3	3	3	pA
Input Bias Current	I_B		±15	±15	±15	±15	±15	pA
Slew Rate	SR	$A_{VCL} = +1$	17	17	16	16	15	V/μs
Settling Time	t_S	to 0.01%	2.2	2.2	2.3	2.3	2.4	μs
		to 0.05%	1.1	1.1	1.1	1.1	1.2	
		to 0.10%	0.9	0.9	0.9	0.9	1.0	
Gain Bandwidth Product	GBW		6.0	6.0	5.7	5.7	5.4	MHz
Closed-Loop Bandwidth	CLBW	$A_{VCL} = +1$	14	14	13	13	12	MHz
Input Noise Voltage Density	e_n	$f_O = 100Hz$	20	20	20	20	20	nV/√Hz
		$f_O = 1000Hz$	15	15	15	15	15	
Input Noise Current Density	i_n	$f_O = 100Hz$ $f_O = 1000Hz$	0.01	0.01	0.01	0.01	0.01	pA/√Hz
Input Capacitance	C_{IN}		3	3	3	3	3	pF

TYPICAL PERFORMANCE CHARACTERISTICS

LARGE-SIGNAL TRANSIENT RESPONSE

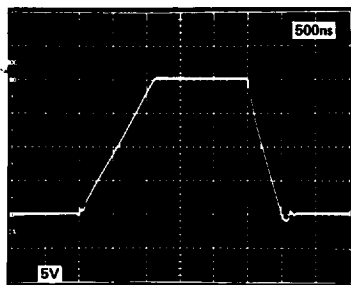

SMALL-SIGNAL TRANSIENT RESPONSE

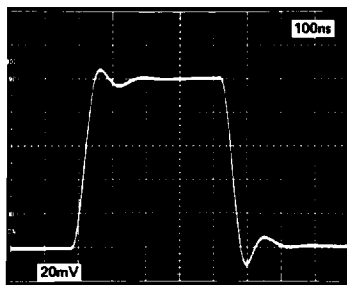

SETTLING TIME

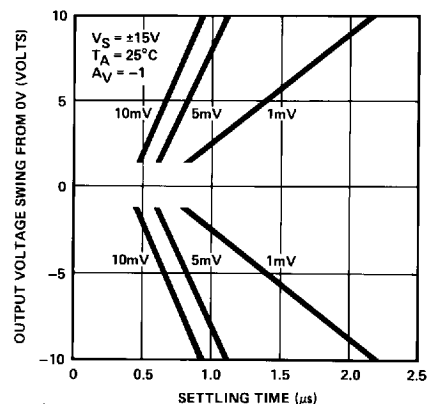

CLOSED-LOOP BANDWIDTH AND PHASE SHIFT vs FREQUENCY

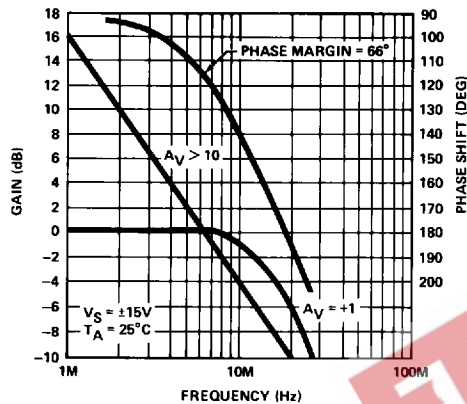

BANDWIDTH vs TEMPERATURE

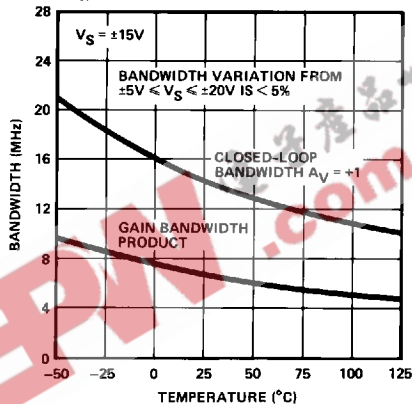

OPEN-LOOP FREQUENCY RESPONSE

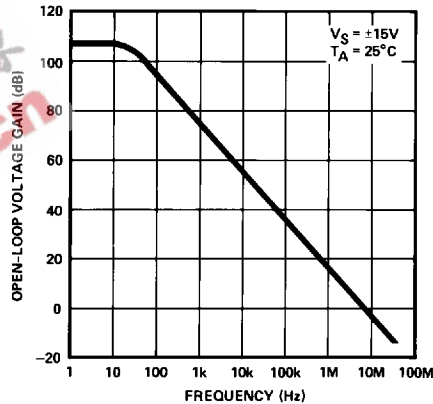

MAXIMUM OUTPUT SWING vs FREQUENCY

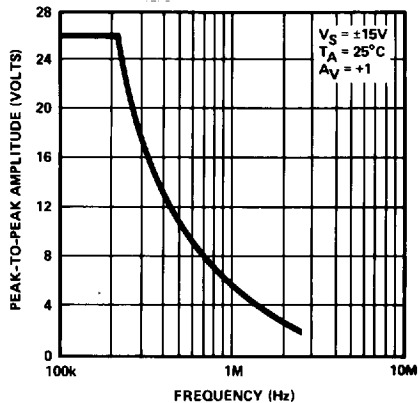

SLEW RATE vs TEMPERATURE

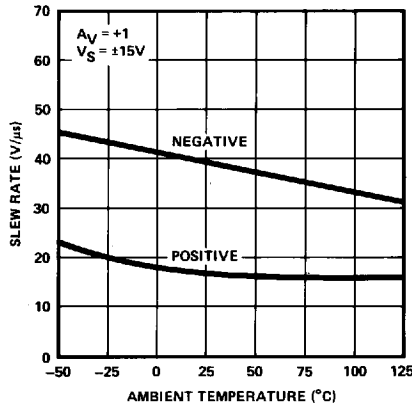

COMMON-MODE REJECTION RATIO vs FREQUENCY

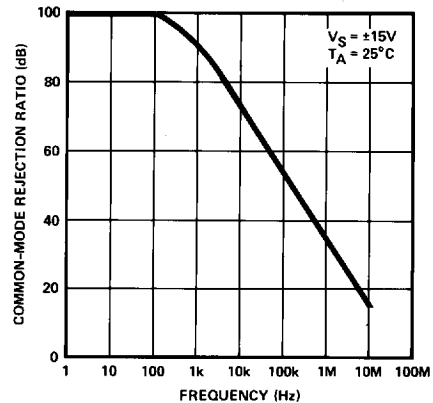

OP-215

TYPICAL PERFORMANCE CHARACTERISTICS

POWER SUPPLY REJECTION vs FREQUENCY

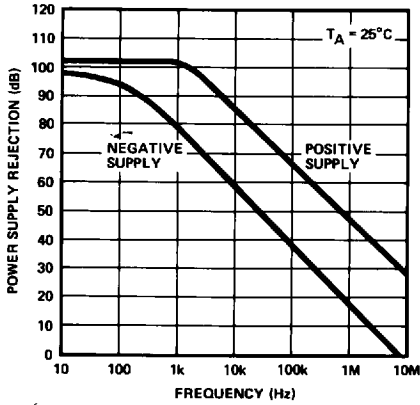

OUTPUT IMPEDANCE vs FREQUENCY

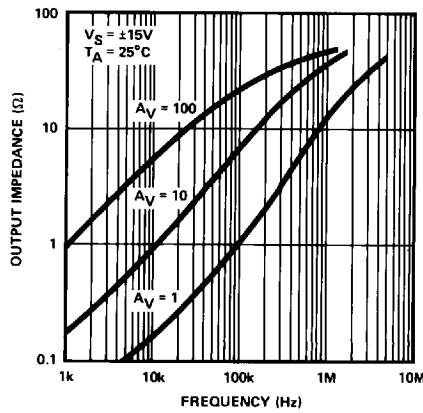

VOLTAGE NOISE DENSITY vs FREQUENCY

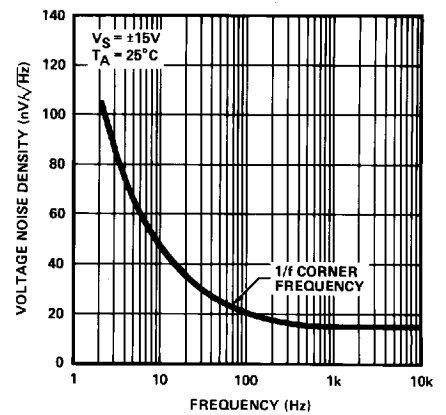

BASIC CONNECTIONS

SETTLING TIME TEST CIRCUIT

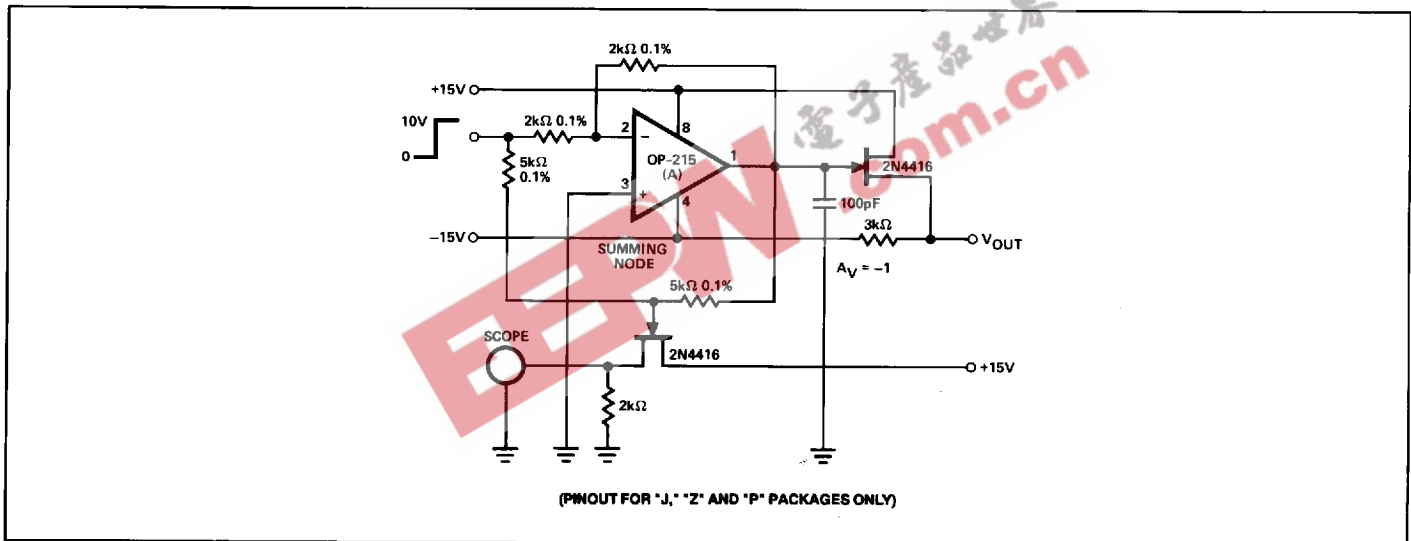

SLEW RATE TEST CIRCUIT

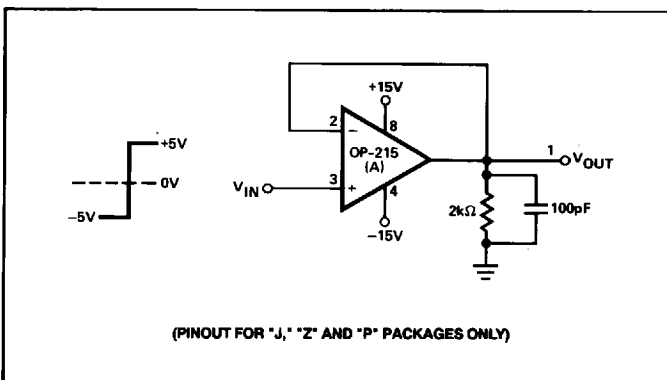

INPUT OFFSET VOLTAGE NULLING

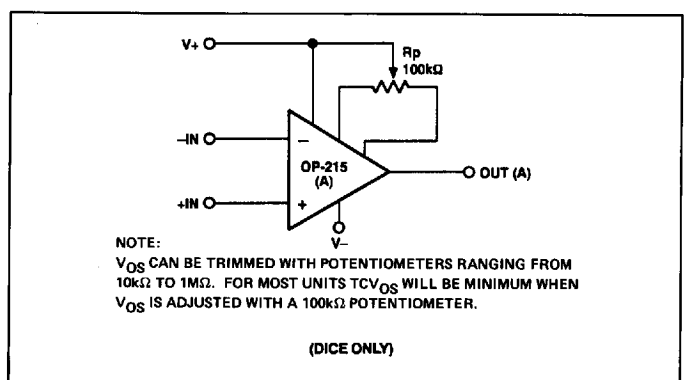

BASIC CONNECTIONS

BURN-IN CIRCUIT

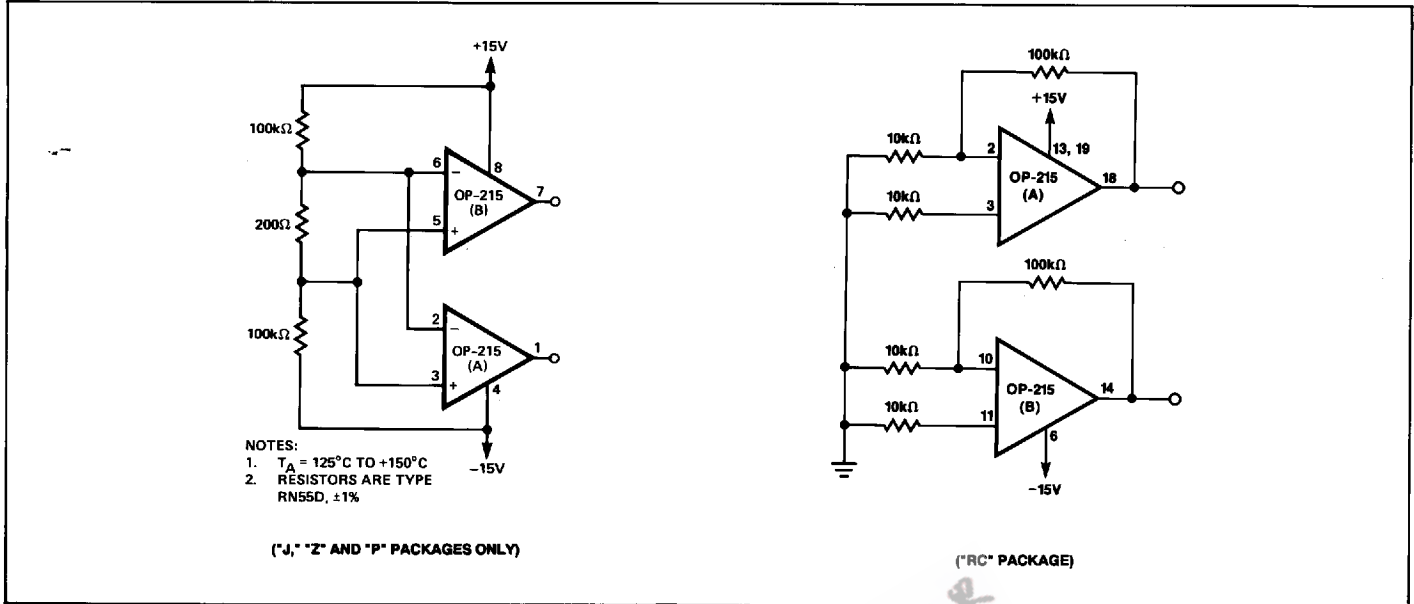

APPLICATIONS INFORMATION

DYNAMIC OPERATING CONSIDERATIONS

As with most amplifiers, care should be taken with lead dress, component placement and supply decoupling in order to ensure stability. For example, resistors from the output to an input should be placed with the body close to the input to minimize “pick-up” and maximize the frequency of the feedback pole by minimizing the capacitance from the input to ground.

A feedback pole is created when the feedback around any amplifier is resistive. The parallel resistance and capacitance from the input of the device (usually the inverting input) to

AC ground sets the frequency of the pole. In many instances, the frequency of this pole is much greater than the expected 3dB frequency of the closed-loop gain and consequently there is negligible effect on stability margin. However, if the feedback pole is less than approximately six times the expected 3dB frequency, a lead capacitor should be placed from the output to the negative input of the op amp. The value of the added capacitor should be such that the RC time constant of this capacitor and the resistance it parallels is greater than, or equal to, the original feedback-pole time constant.

EEPW 电子产品世界
.com.cn