

OP07C, OP07D PRECISION OPERATIONAL AMPLIFIERS

SLOS099E – OCTOBER 1983 – REVISED MAY 2004

- **Low Noise**
- **No External Components Required**
- **Replace Chopper Amplifiers at a Lower Cost**
- **Wide Input-Voltage Range**
... 0 to ± 14 V Typ
- **Wide Supply-Voltage Range**
... ± 3 V to ± 18 V

**D OR P PACKAGE
(TOP VIEW)**

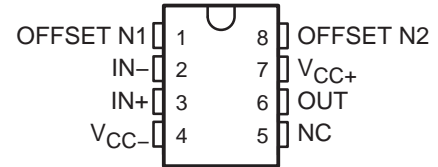

NC – No internal connection

description/ordering information

These devices offer low offset and long-term stability by means of a low-noise, chopperless, bipolar-input-transistor amplifier circuit. For most applications, external components are not required for offset nulling and frequency compensation. The true differential input, with a wide input-voltage range and outstanding common-mode rejection, provides maximum flexibility and performance in high-noise environments and in noninverting applications. Low bias currents and extremely high input impedances are maintained over the entire temperature range. The OP07 is unsurpassed for low-noise, high-accuracy amplification of very-low-level signals.

These devices are characterized for operation from 0°C to 70°C.

ORDERING INFORMATION

TA	PACKAGE†		ORDERABLE PART NUMBER	TOP-SIDE MARKING
0°C to 70°C	PDIP (P)	Tube of 50	OP07CP	OP07CP
		Tube of 50	OP07DP	OP07DP
	SOIC (D)	Tube of 75	OP07CD	OP07C
		Reel of 2500	OP07CDR	
		Tube of 75	OP07DD	OP07D
		Reel of 2500	OP07DDR	

† Package drawings, standard packing quantities, thermal data, symbolization, and PCB design guidelines are available at www.ti.com/sc/package.

symbol

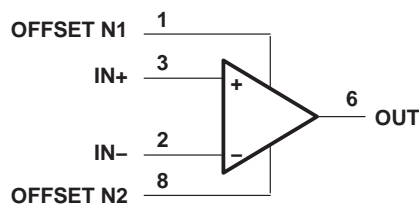

Please be aware that an important notice concerning availability, standard warranty, and use in critical applications of Texas Instruments semiconductor products and disclaimers thereto appears at the end of this data sheet.

PRODUCTION DATA information is current as of publication date. Products conform to specifications per the terms of Texas Instruments standard warranty. Production processing does not necessarily include testing of all parameters.

**TEXAS
INSTRUMENTS**

POST OFFICE BOX 655303 • DALLAS, TEXAS 75265

Copyright © 2004, Texas Instruments Incorporated

OP07C, OP07D PRECISION OPERATIONAL AMPLIFIERS

SLOS099E – OCTOBER 1983 – REVISED MAY 2004

schematic

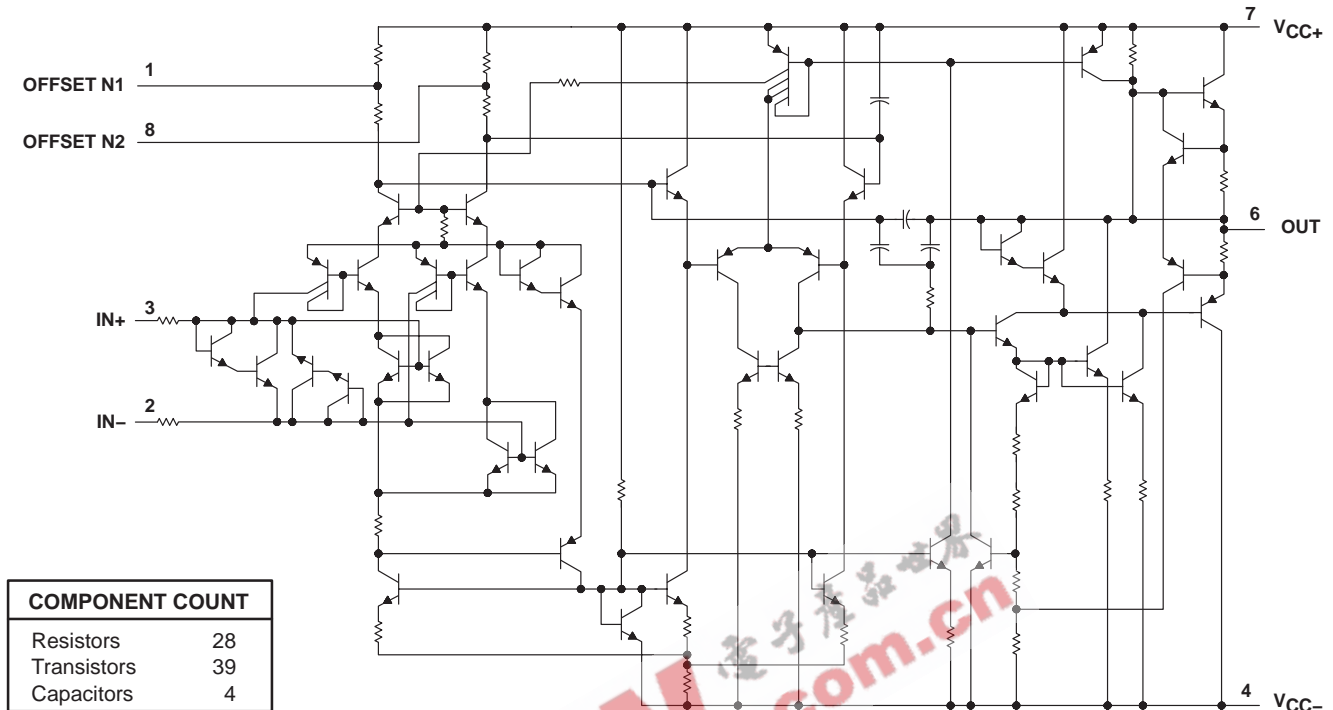

absolute maximum ratings over operating free-air temperature range (unless otherwise noted)†

Supply voltage: V_{CC+} (see Note 1)	22 V
V_{CC-} (see Note 1)	-22 V
Differential input voltage (see Note 2)	± 30 V
Input voltage, V_I (either input, see Note 3)	± 22 V
Duration of output short circuit (see Note 4)	Unlimited
Package thermal impedance, θ_{JA} (see Notes 5 and 6): D package	97°C/W
P package	85°C/W
Operating virtual junction temperature, T_J	150°C
Lead temperature 1,6 mm (1/16 inch) from case for 10 seconds	260°C
Storage temperature range, T_{stg}	-65°C to 150°C

† Stresses beyond those listed under "absolute maximum ratings" may cause permanent damage to the device. These are stress ratings only, and functional operation of the device at these or any other conditions beyond those indicated under "recommended operating conditions" is not implied. Exposure to absolute-maximum-rated conditions for extended periods may affect device reliability.

- NOTES:
- All voltage values, unless otherwise noted, are with respect to the midpoint between V_{CC+} and V_{CC-} .
 - Differential voltages are at $IN+$ with respect to $IN-$.
 - The magnitude of the input voltage must never exceed the magnitude of the supply voltage or 15 V, whichever is less.
 - The output may be shorted to ground or to either power supply.
 - Maximum power dissipation is a function of $T_J(max)$, θ_{JA} , and T_A . The maximum allowable power dissipation at any allowable ambient temperature is $P_D = (T_J(max) - T_A)/\theta_{JA}$. Selecting the maximum of 150°C can affect reliability.
 - The package thermal impedance is calculated in accordance with JESD 51-7.

OP07C, OP07D PRECISION OPERATIONAL AMPLIFIERS

SLOS099E – OCTOBER 1983 – REVISED MAY 2004

recommended operating conditions

		MIN	MAX	UNIT
$V_{CC\pm}$	Supply voltage	± 3	± 18	V
V_{IC}	Common-mode input voltage	$V_{CC\pm} = \pm 15$ V		V
T_A	Operating free-air temperature	0	70	°C

EEPW 电子產品世界
.com.cn

OP07C, OP97D PRECISION OPERATIONAL AMPLIFIERS

SLOS099E – OCTOBER 1983 – REVISED MAY 2004

electrical characteristics at specified free-air temperature, $V_{CC\pm} = \pm 15\text{ V}$ (unless otherwise noted)

PARAMETER	TEST CONDITION†	T _A	OP07C			OP07D			UNIT
			MIN	TYP	MAX	MIN	TYP	MAX	
V _{IO}	V _O = 0, R _S = 50 Ω	25°C	60	150	150	60	150	150	μV
		0°C to 70°C	85	250	250	85	250	250	
α _{VIO}	V _O = 0, R _S = 50 Ω	0°C to 70°C	0.5	1.8	1.8	0.7	2.5	2.5	μV/°C
	See Note 6		0.4			0.5			μV/mo
	R _S = 20 kΩ, See Figure 1	25°C	±4			±4			mV
I _{IO}		25°C	0.8	6	6	0.8	6	6	nA
		0°C to 70°C	1.6	8	8	1.6	8	8	
α _{IIO}		0°C to 70°C	12	50	50	12	50	50	pA/°C
I _{IB}		25°C	±1.8	±7	±7	±2	±12	±12	nA
		0°C to 70°C	±2.2	±9	±9	±3	±14	±14	
α _{IIB}		0°C to 70°C	18	50	50	18	50	50	pA/°C
V _{ICR}		25°C	±13	±14		±13	±14		V
		0°C to 70°C	±13	±13.5		±13	±13.5		
V _{OM}	R _L ≥ 10 kΩ	25°C	±12	±13		±12	±13		V
	R _L ≥ 2 kΩ		±11.5	±12.8		±11.5	±12.8		
	R _L ≥ 1 kΩ		±12			±12			
	R _L ≥ 2 kΩ	0°C to 70°C	±11	±12.6		±11	±12.6		
	V _{CC±} = ±3 V, V _O = ±0.5 V, R _L ≥ 500 kΩ	25°C	100	400		400			V/mV
		25°C	120	400		120	400		
	V _O = ±10 V, R _L = 2 kΩ	0°C to 70°C	100	400		100	400		
B ₁		25°C	0.4	0.6		0.4	0.6		MHz
r _i		25°C	8	33		7	31		MΩ
CMRR	V _{IC} = ±13 V, R _S = 50 Ω	25°C	100	120		94	110		dB
		0°C to 70°C	97	120		94	106		
k _{SVS}	V _{CC±} = ±3 V to ±18 V, R _S = 50 Ω	25°C	7	32		7	32		μV/V
		0°C to 70°C	10	51		10	51		
P _D	V _O = 0, No load	25°C	80	150		80	150		mW
	V _{CC±} = ±3 V, V _O = 0, No load		4	8		4	8		

† All characteristics are measured under open-loop conditions, with zero common-mode input voltage, unless otherwise noted.
NOTE 7: Since long-term drift cannot be measured on the individual devices prior to shipment, this specification is not intended to be a warranty. It is an engineering estimate of the averaged trend line of drift versus time over extended periods after the first 30 days of operation.

OP07C, OP07D PRECISION OPERATIONAL AMPLIFIERS

SLOS099E – OCTOBER 1983 – REVISED MAY 2004

operating characteristics, $V_{CC\pm} = \pm 15\text{ V}$, $T_A = 25^\circ\text{C}$

PARAMETER	TEST CONDITION [†]	OP07C	OP07D	UNIT
		TYP	TYP	
V_n Equivalent input noise voltage	$f = 10\text{ Hz}$	10.5	10.5	$\text{nV}/\sqrt{\text{Hz}}$
	$f = 100\text{ Hz}$	10.2	10.3	
	$f = 1\text{ kHz}$	9.8	9.8	
$V_N(\text{PP})$ Peak-to-peak equivalent input noise voltage	$f = 0.1\text{ Hz to }10\text{ Hz}$	0.38	0.38	μV
I_n Equivalent input noise current	$f = 10\text{ Hz}$	0.35	0.35	$\text{pA}/\sqrt{\text{Hz}}$
	$f = 100\text{ Hz}$	0.15	0.15	
	$f = 1\text{ kHz}$	0.13	0.13	
$I_N(\text{PP})$ Peak-to-peak equivalent input noise current	$f = 0.1\text{ Hz to }10\text{ Hz}$	15	15	pA
SR Slew rate	$R_L \geq 2\text{ k}\Omega$	0.3	0.3	$\text{V}/\mu\text{s}$

[†] All characteristics are measured under open-loop conditions, with zero common-mode input voltage, unless otherwise noted.

APPLICATION INFORMATION

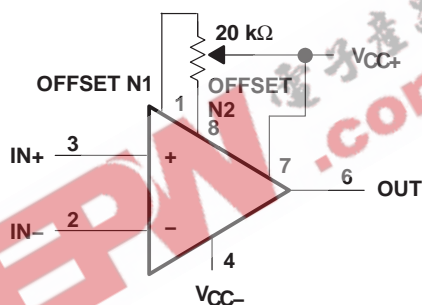

Figure 1. Input Offset-Voltage Null Circuit

PACKAGING INFORMATION

Orderable Device	Status ⁽¹⁾	Package Type	Package Drawing	Pins	Package Qty	Eco Plan ⁽²⁾	Lead/Ball Finish	MSL Peak Temp ⁽³⁾
OP-07DPSR	ACTIVE	SO	PS	8	2000	Green (RoHS & no Sb/Br)	CU NIPDAU	Level-1-260C-UNLIM
OP-07DPSRE4	ACTIVE	SO	PS	8	2000	Green (RoHS & no Sb/Br)	CU NIPDAU	Level-1-260C-UNLIM
OP07CD	ACTIVE	SOIC	D	8	75	Green (RoHS & no Sb/Br)	CU NIPDAU	Level-1-260C-UNLIM
OP07CDE4	ACTIVE	SOIC	D	8	75	Green (RoHS & no Sb/Br)	CU NIPDAU	Level-1-260C-UNLIM
OP07CDG4	ACTIVE	SOIC	D	8	75	Green (RoHS & no Sb/Br)	CU NIPDAU	Level-1-260C-UNLIM
OP07CDR	ACTIVE	SOIC	D	8	2500	Green (RoHS & no Sb/Br)	CU NIPDAU	Level-1-260C-UNLIM
OP07CDRE4	ACTIVE	SOIC	D	8	2500	Green (RoHS & no Sb/Br)	CU NIPDAU	Level-1-260C-UNLIM
OP07CDRG4	ACTIVE	SOIC	D	8	2500	Green (RoHS & no Sb/Br)	CU NIPDAU	Level-1-260C-UNLIM
OP07CP	ACTIVE	PDIP	P	8	50	Pb-Free (RoHS)	CU NIPDAU	N / A for Pkg Type
OP07CPE4	ACTIVE	PDIP	P	8	50	Pb-Free (RoHS)	CU NIPDAU	N / A for Pkg Type
OP07DD	ACTIVE	SOIC	D	8	75	Green (RoHS & no Sb/Br)	CU NIPDAU	Level-1-260C-UNLIM
OP07DDE4	ACTIVE	SOIC	D	8	75	Green (RoHS & no Sb/Br)	CU NIPDAU	Level-1-260C-UNLIM
OP07DDR	ACTIVE	SOIC	D	8	2500	Green (RoHS & no Sb/Br)	CU NIPDAU	Level-1-260C-UNLIM
OP07DDRE4	ACTIVE	SOIC	D	8	2500	Green (RoHS & no Sb/Br)	CU NIPDAU	Level-1-260C-UNLIM
OP07DP	ACTIVE	PDIP	P	8	50	Pb-Free (RoHS)	CU NIPDAU	N / A for Pkg Type
OP07DPE4	ACTIVE	PDIP	P	8	50	Pb-Free (RoHS)	CU NIPDAU	N / A for Pkg Type

⁽¹⁾ The marketing status values are defined as follows:

ACTIVE: Product device recommended for new designs.

LIFEBUY: TI has announced that the device will be discontinued, and a lifetime-buy period is in effect.

NRND: Not recommended for new designs. Device is in production to support existing customers, but TI does not recommend using this part in a new design.

PREVIEW: Device has been announced but is not in production. Samples may or may not be available.

OBSOLETE: TI has discontinued the production of the device.

⁽²⁾ Eco Plan - The planned eco-friendly classification: Pb-Free (RoHS), Pb-Free (RoHS Exempt), or Green (RoHS & no Sb/Br) - please check <http://www.ti.com/productcontent> for the latest availability information and additional product content details.

TBD: The Pb-Free/Green conversion plan has not been defined.

Pb-Free (RoHS): TI's terms "Lead-Free" or "Pb-Free" mean semiconductor products that are compatible with the current RoHS requirements for all 6 substances, including the requirement that lead not exceed 0.1% by weight in homogeneous materials. Where designed to be soldered at high temperatures, TI Pb-Free products are suitable for use in specified lead-free processes.

Pb-Free (RoHS Exempt): This component has a RoHS exemption for either 1) lead-based flip-chip solder bumps used between the die and package, or 2) lead-based die adhesive used between the die and leadframe. The component is otherwise considered Pb-Free (RoHS compatible) as defined above.

Green (RoHS & no Sb/Br): TI defines "Green" to mean Pb-Free (RoHS compatible), and free of Bromine (Br) and Antimony (Sb) based flame retardants (Br or Sb do not exceed 0.1% by weight in homogeneous material)

(3) MSL, Peak Temp. -- The Moisture Sensitivity Level rating according to the JEDEC industry standard classifications, and peak solder temperature.

Important Information and Disclaimer:The information provided on this page represents TI's knowledge and belief as of the date that it is provided. TI bases its knowledge and belief on information provided by third parties, and makes no representation or warranty as to the accuracy of such information. Efforts are underway to better integrate information from third parties. TI has taken and continues to take reasonable steps to provide representative and accurate information but may not have conducted destructive testing or chemical analysis on incoming materials and chemicals. TI and TI suppliers consider certain information to be proprietary, and thus CAS numbers and other limited information may not be available for release.

In no event shall TI's liability arising out of such information exceed the total purchase price of the TI part(s) at issue in this document sold by TI to Customer on an annual basis.

EEPW 电子產品世界
.com.cn

MECHANICAL DATA

MPDI001A – JANUARY 1995 – REVISED JUNE 1999

P (R-PDIP-T8)

PLASTIC DUAL-IN-LINE



- NOTES: A. All linear dimensions are in inches (millimeters).
 B. This drawing is subject to change without notice.
 C. Falls within JEDEC MS-001

For the latest package information, go to http://www.ti.com/sc/docs/package/pkg_info.htm



POST OFFICE BOX 655303 • DALLAS, TEXAS 75265

MECHANICAL DATA

D (R-PDSO-G8)

PLASTIC SMALL-OUTLINE PACKAGE

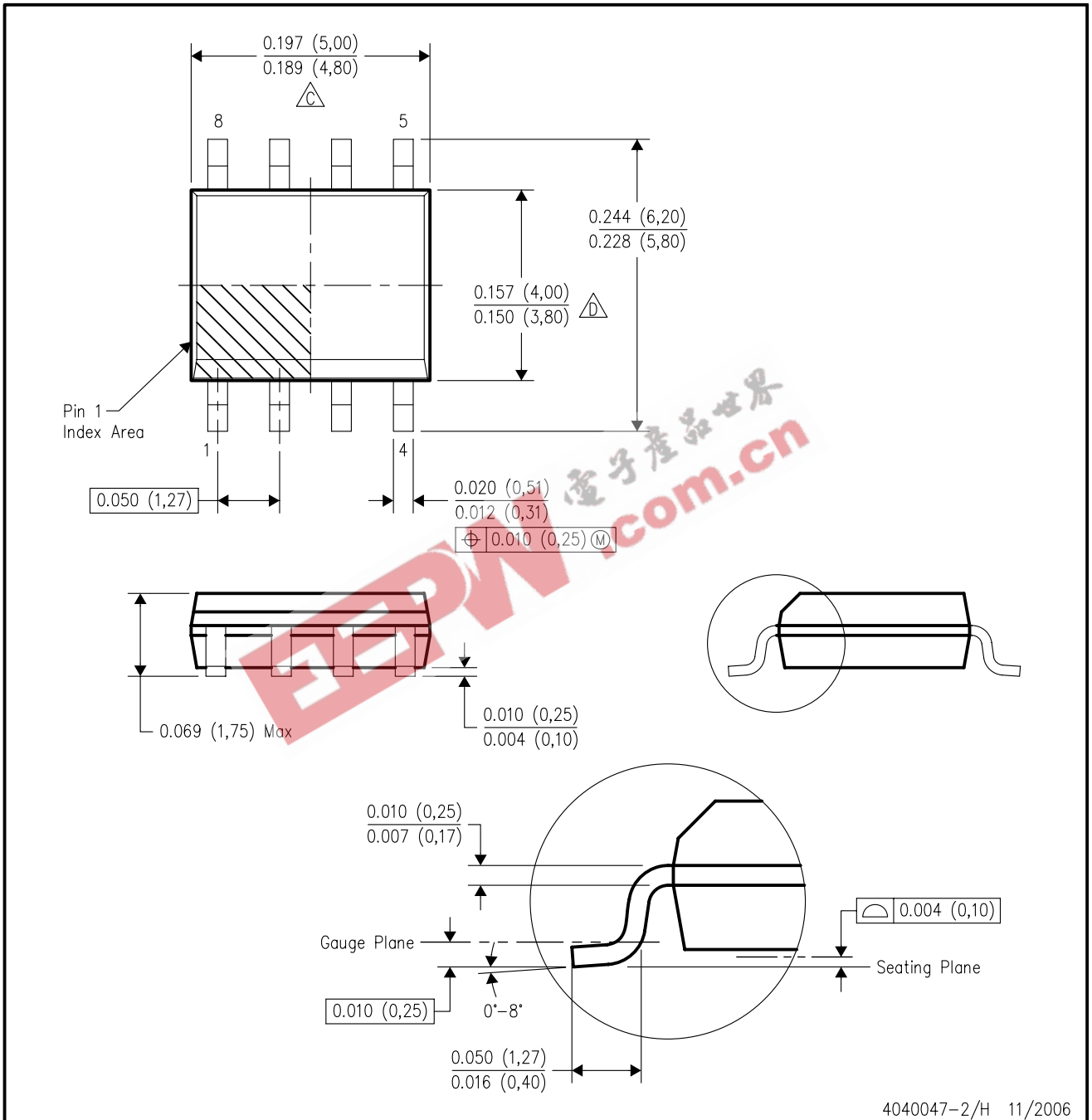

- NOTES:
- A. All linear dimensions are in inches (millimeters).
 - B. This drawing is subject to change without notice.
 - C. Body length does not include mold flash, protrusions, or gate burrs. Mold flash, protrusions, or gate burrs shall not exceed .006 (0,15) per end.
 - D. Body width does not include interlead flash. Interlead flash shall not exceed .017 (0,43) per side.
 - E. Reference JEDEC MS-012 variation AA.

MECHANICAL DATA

PS (R-PDSO-G8)

PLASTIC SMALL-OUTLINE PACKAGE

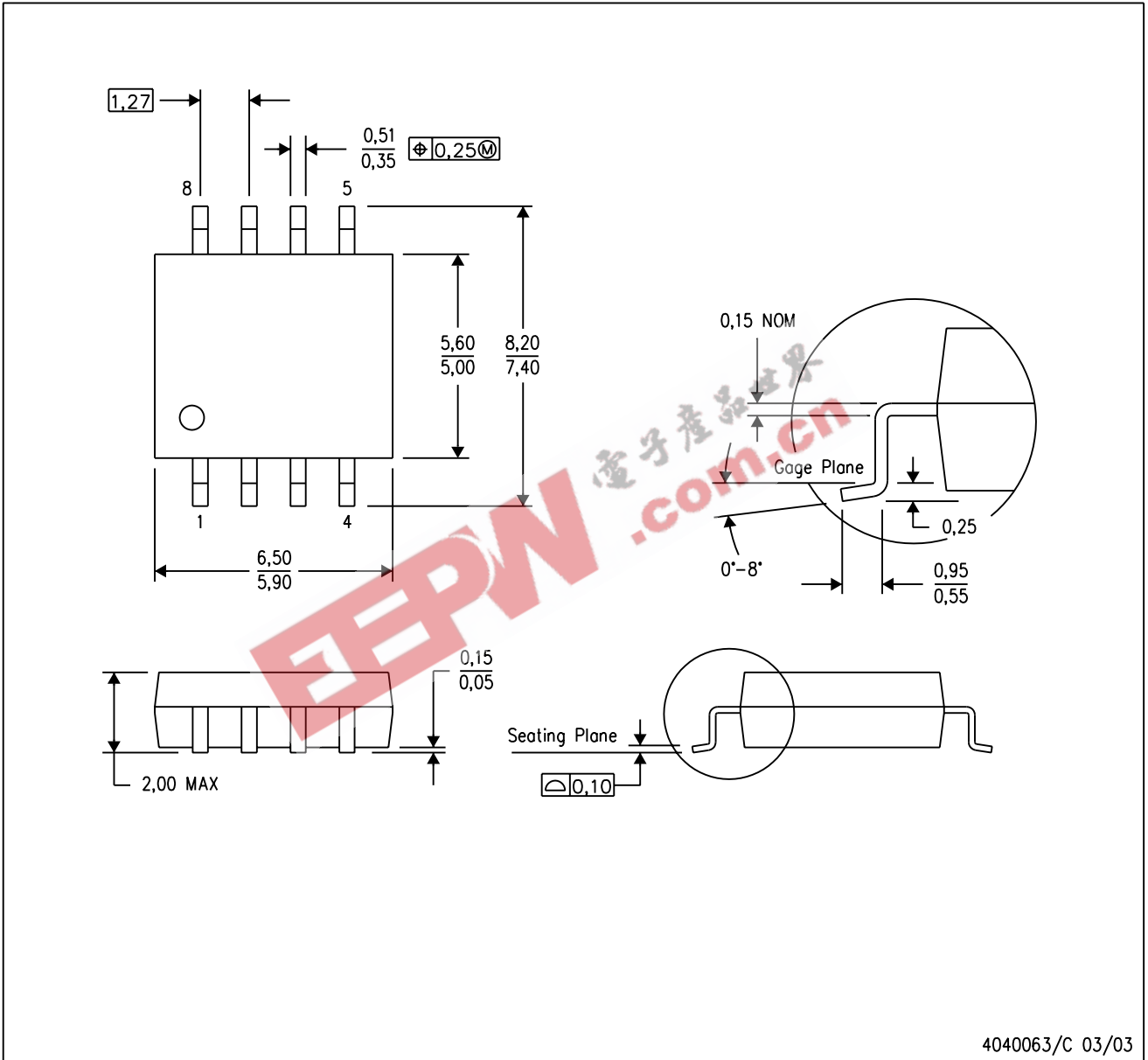

- NOTES:
- A. All linear dimensions are in millimeters.
 - B. This drawing is subject to change without notice.
 - C. Body dimensions do not include mold flash or protrusion, not to exceed 0,15.

IMPORTANT NOTICE

Texas Instruments Incorporated and its subsidiaries (TI) reserve the right to make corrections, modifications, enhancements, improvements, and other changes to its products and services at any time and to discontinue any product or service without notice. Customers should obtain the latest relevant information before placing orders and should verify that such information is current and complete. All products are sold subject to TI's terms and conditions of sale supplied at the time of order acknowledgment.

TI warrants performance of its hardware products to the specifications applicable at the time of sale in accordance with TI's standard warranty. Testing and other quality control techniques are used to the extent TI deems necessary to support this warranty. Except where mandated by government requirements, testing of all parameters of each product is not necessarily performed.

TI assumes no liability for applications assistance or customer product design. Customers are responsible for their products and applications using TI components. To minimize the risks associated with customer products and applications, customers should provide adequate design and operating safeguards.

TI does not warrant or represent that any license, either express or implied, is granted under any TI patent right, copyright, mask work right, or other TI intellectual property right relating to any combination, machine, or process in which TI products or services are used. Information published by TI regarding third-party products or services does not constitute a license from TI to use such products or services or a warranty or endorsement thereof. Use of such information may require a license from a third party under the patents or other intellectual property of the third party, or a license from TI under the patents or other intellectual property of TI.

Reproduction of information in TI data books or data sheets is permissible only if reproduction is without alteration and is accompanied by all associated warranties, conditions, limitations, and notices. Reproduction of this information with alteration is an unfair and deceptive business practice. TI is not responsible or liable for such altered documentation.

Resale of TI products or services with statements different from or beyond the parameters stated by TI for that product or service voids all express and any implied warranties for the associated TI product or service and is an unfair and deceptive business practice. TI is not responsible or liable for any such statements.

Following are URLs where you can obtain information on other Texas Instruments products and application solutions:

Products		Applications	
Amplifiers	amplifier.ti.com	Audio	www.ti.com/audio
Data Converters	dataconverter.ti.com	Automotive	www.ti.com/automotive
DSP	dsp.ti.com	Broadband	www.ti.com/broadband
Interface	interface.ti.com	Digital Control	www.ti.com/digitalcontrol
Logic	logic.ti.com	Military	www.ti.com/military
Power Mgmt	power.ti.com	Optical Networking	www.ti.com/opticalnetwork
Microcontrollers	microcontroller.ti.com	Security	www.ti.com/security
Low Power Wireless	www.ti.com/lpw	Telephony	www.ti.com/telephony
		Video & Imaging	www.ti.com/video
		Wireless	www.ti.com/wireless

Mailing Address: Texas Instruments
Post Office Box 655303 Dallas, Texas 75265