

# Plastic Infrared Emitting Diode

## OP265AA Series



### Features:

- T-1 (3 mm) package style
- Narrow irradiance pattern
- Dome lens
- Higher power output than GaAs at equivalent drive currents
- 850 nm diode

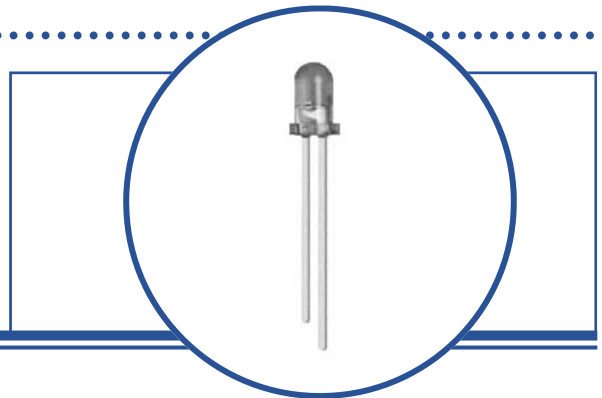

### Description:

Each device in the **OP265AA** series is a high intensity gallium arsenide infrared emitting diode (GaAIAs) that is molded in an IR transmissive clear or amber-tinted epoxy package with a dome lens. Devices feature a narrow source irradiance pattern and a variety of electrical characteristics. The small T-1 package style makes these devices ideal for space-limited applications.

These devices are mechanically and spectrally matched to other OPTEK products as follows:

*OP265 devices conform to the OP505 and OP535 series devices.*

*Please refer to Application Bulletins 208 and 210 for additional design information and reliability (degradation) data.*

### Applications:

- Space-limited applications
- Applications requiring coupling efficiency
- Battery-operated or voltage-limited applications

Ordering Information					
Part Number	LED Peak Wavelength	Output Power (mW/cm <sup>2</sup> ) Min / Max	I <sub>F</sub> (mA) Typ / Max	Total Beam Angle	Lead Length
OP265AA	850 nm	6.0 / NA	20 / 50	18°	0.50"
OP265AB		8.0 / 12.0			
OP265AC		12.0 / 16.0			
OP265AD		16.0 / NA			

DIMENSIONS ARE IN: [MILLIMETERS]  
[INCHES]

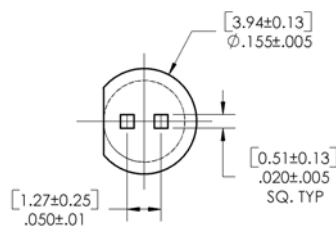
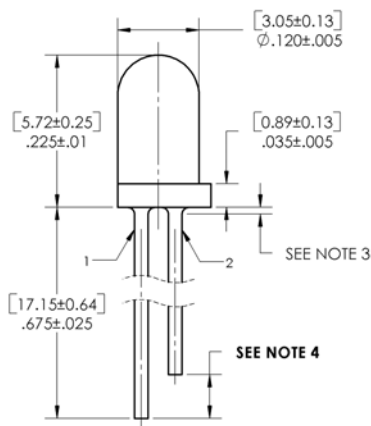

#### DISCRETE PIN-OUT

- 1 CATHODE
- 2 ANODE



**IMPORTANT:**  
For identification purposes, ANODE lead is shorter than the CATHODE lead in order to differentiate this product from regular OP265 and/or OP313.

#### NOTES:

1. OUTSIDE DISCRETE SHELL IS POLYSULFONE P1700 CLEAR.
2. THIS LED IS BUILT WITH A 850nm CHIP.
3. MAX ALLOWABLE EPOXY MINISCUS IS 0.030.
4. FOR IDENTIFICATION PURPOSES, ANODE LEAD IS .065 ± .035 SHORTER THAN THE CATHODE LEAD.

Pin #	LED
1	Cathode
2	Anode



RoHS

OPTEK reserves the right to make changes at any time in order to improve design and to supply the best product possible.

**CONTAINS POLYSULFONE**  
To avoid stress cracking, we suggest using ND Industries' **Vibra-Tite** for thread-locking. **Vibra-Tite** evaporates fast without causing structural failure in OPTEK'S molded plastics.

# Plastic Infrared Emitting Diode

## OP265AA Series



### Absolute Maximum Ratings ( $T_A=25^\circ\text{C}$ unless otherwise noted)

Storage and Operating Temperature Range	-40° C to +100° C
Reverse Voltage	2.0 V
Continuous Forward Current	50 mA
Peak Forward Current (1 $\mu\text{s}$ pulse width, 300 pps)	3.0 A
Lead Soldering Temperature [1/16 inch (1.6 mm) from case for 5 seconds with soldering iron]	260° C <sup>(1)</sup>
Power Dissipation	100 mW <sup>(2)</sup>

Notes:

1. RMA flux is recommended. Duration can be extended to 10 second maximum when flow soldering. A maximum of 20 grams force may be applied to the leads when soldering.
2. Derate linearly at 1.33 mW/° C above 25° C.
3.  $E_{E(APT)}$  is a measurement of the average apertured radiant incidence upon a sensing area 0.081" (2.06 mm) in diameter, perpendicular to and centered on the mechanical axis of the lens and 0.590" (14.99 mm) from the measurement surface.  $E_{E(APT)}$  is not necessarily uniform within the measured area.

### Electrical Characteristics ( $T_A = 25^\circ\text{C}$ unless otherwise noted)

SYMBOL	PARAMETER	MIN	TYP	MAX	UNITS	TEST CONDITIONS
--------	-----------	-----	-----	-----	-------	-----------------

#### Input Diode

$E_{E(APT)}$	Apertured Radiant Incidence					$I_F = 20\text{ mA}$ Aperture = 0.081" diameter Distance = 0.590" from seating surface to aperture surface
	OP265AA	5.50	-	-	mW/cm <sup>2</sup>	
	OP265AB	7.50	-	12.5		
	OP265AC	11.50	-	16.5		
OP265AD	15.50	-	-			
$V_F$	Forward Voltage	-	-	1.80	V	$I_F = 20\text{ mA}$
$I_R$	Reverse Current	-	10	-	$\mu\text{A}$	$V_R = 10\text{ V}$
$\lambda_P$	Wavelength at Peak Emission	-	850	-	nm	$I_F = 10\text{ mA}$
$\Delta\lambda_P / \Delta T$	Spectral Shift with Temperature	-	$\pm 0.18$	-	nm/°C	$I_F = \text{Constant}$
$\theta_{HP}$	Emission Angle at Half Power Points	-	18	-	Degree	$I_F = 20\text{ mA}$
$t_r$	Output Rise Time	-	10	-	ns	$I_{F(PK)} = 100\text{ mA}$ , PW=10 $\mu\text{s}$ , D.C.=10.0%
$t_f$	Output Fall Time	-	10	-	ns	

OPTEK reserves the right to make changes at any time in order to improve design and to supply the best product possible.

# Plastic Infrared Emitting Diode

## OP265AA Series



### OP265 (AA, AB, AC, AD)

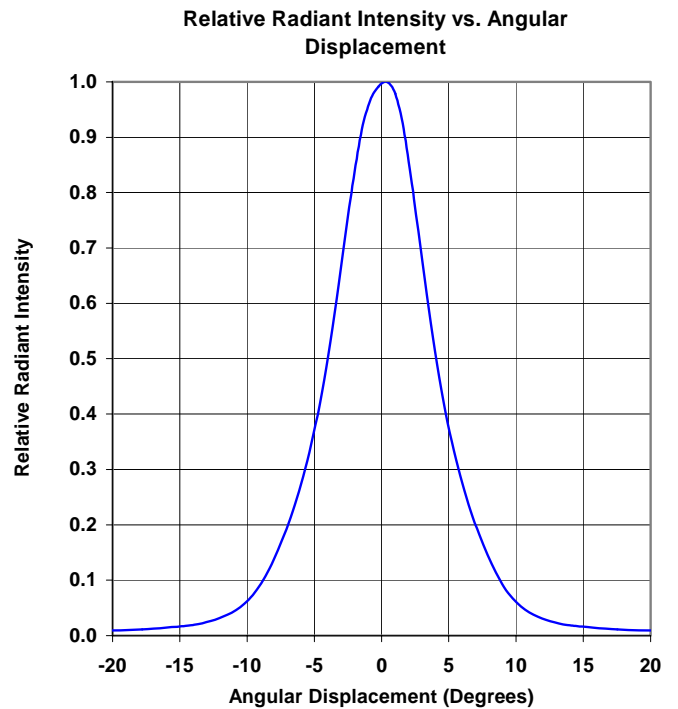
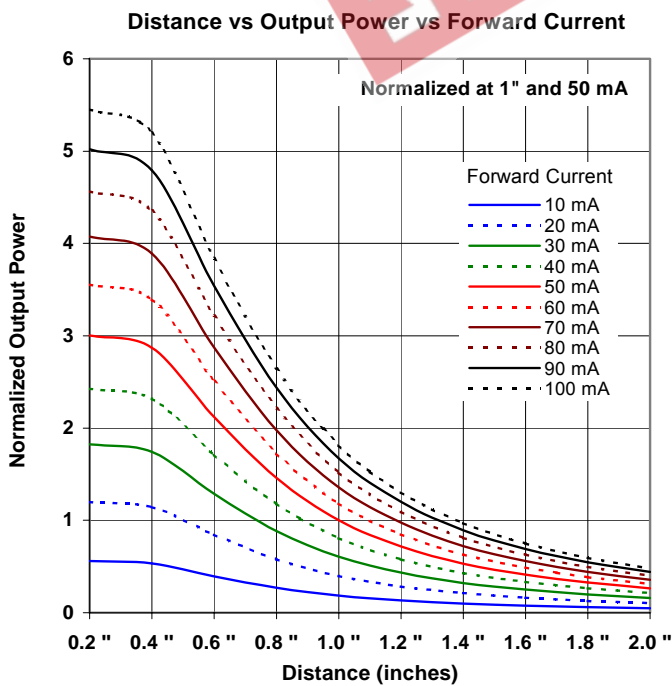
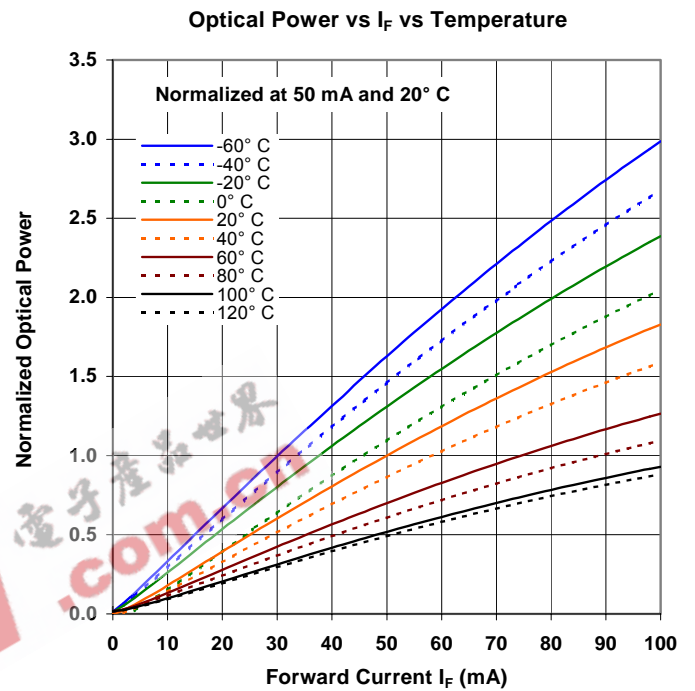
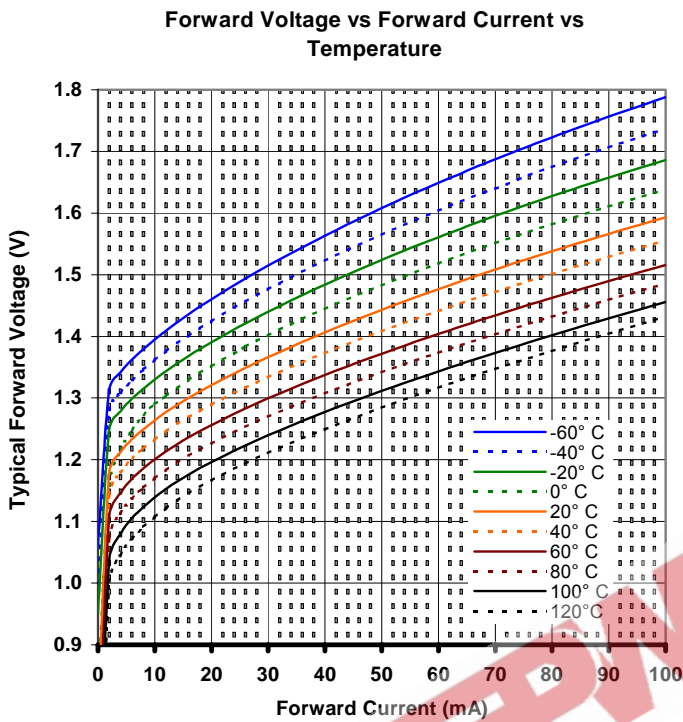

OPTEK reserves the right to make changes at any time in order to improve design and to supply the best product possible.