



OPA501

High Current, High Power OPERATIONAL AMPLIFIER

FEATURES

- HIGH OUTPUT CURRENT: $\pm 10A$ Peak
- WIDE POWER SUPPLY RANGE:
 ± 10 to $\pm 40V$
- LOW QUIESCENT CURRENT: 2.6mA
- ISOLATED CASE TO-3 PACKAGE

APPLICATIONS

- MOTOR DRIVER
- SERVO AMPLIFIER
- VALVE ACTUATOR
- SYNCRO DRIVER
- PROGRAMMABLE POWER SUPPLY

DESCRIPTION

The OPA501 is a high output current operational amplifier. It can be used in virtually all common op amp circuits, yet is capable of output currents up to $\pm 10A$. Power supply voltages up to $\pm 40V$ allow very high output power for driving motors or other electro-mechanical loads.

Safe operating area is fully specified, and user-set current limits provide protection for both the amplifier and load. The class-B (zero output stage bias) provides low quiescent current during small-signal conditions.

This rugged hybrid integrated circuit is packaged in a metal 8-pin TO-3 package. Both industrial and military temperature range models are available.

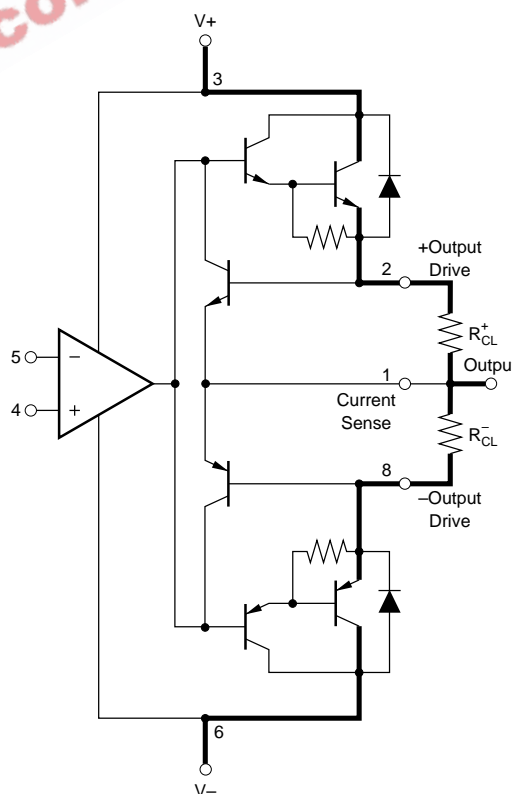

SPECIFICATIONS

ELECTRICAL

At $T_c = +25^\circ\text{C}$, $V_s = \pm 28\text{V}$, (OPA501RM, AM); $V_s = \pm 34\text{V}$ (OPA501SM, BM) unless otherwise noted.

PARAMETER	CONDITIONS	OPA501RM, AM			OPA501SM, BM			UNITS
		MIN	TYP	MAX	MIN	TYP	MAX	
RATED OUTPUT ^(1,2) Output Current Continuous ⁽³⁾ Output Voltage ⁽³⁾	$R_L = 2\Omega$ (RM, AM) $R_L = 2.6\Omega$ (SM, BM) $I_O = 10\text{A peak}$	± 10 ± 10 ± 20	± 23		*	*	± 26 ± 29	A A V
DYNAMIC RESPONSE Bandwidth, Unity Gain Full Power Bandwidth Slew Rate	Small Signal $V_O = 40\text{Vp-p}$, $R_L = 8\Omega$ $R_L = 5\Omega$ (RM, AM) $R_L = 6.5\Omega$ (SM, BM)	10 1.35 1.35	1 16		*	*		MHz kHz V/ μs v/ μs
INPUT OFFSET VOLTAGE Initial Offset vs Temperature vs Supply Voltage	$-25^\circ\text{C} < T < +85^\circ\text{C}$ (AM, BM) $-55^\circ\text{C} < T < +125^\circ\text{C}$ (RM, SM)		± 5 ± 10	± 10 ± 65		± 2 ± 10 *	± 5 ± 40	mV $\mu\text{V}/^\circ\text{C}$ $\mu\text{V}/^\circ\text{C}$ $\mu\text{V}/\text{V}$
INPUT BIAS CURRENT Initial vs Temperature vs Supply Voltage	$T_{\text{CASE}} = +25^\circ\text{C}$		15 ± 0.05 ± 0.02	40		*	20	nA $\text{nA}/^\circ\text{C}$ nA/V
INPUT DIFFERENCE CURRENT Initial vs Temperature	$T_{\text{CASE}} = +25^\circ\text{C}$ $-25^\circ\text{C} < T < +85^\circ\text{C}$ (AM, BM) $-55^\circ\text{C} < T < +125^\circ\text{C}$ (RM, SM)		± 5 ± 0.01	± 10		± 2 ± 0.01	± 3	nA $\text{nA}/^\circ\text{C}$ $\text{nA}/^\circ\text{C}$
OPEN-LOOP GAIN, DC $R_L = 5\Omega$ (RM, AM) $R_L = 6.5\Omega$ (SM, BM)		94	115		98	115		dB dB
INPUT IMPEDANCE Differential Common-mode			10 250			*		$\text{M}\Omega$ $\text{M}\Omega$
INPUT NOISE Voltage Noise $f_n = 10\text{Hz to } 10\text{kHz}$ Current Noise $f_n = 10\text{Hz to } 10\text{kHz}$	$f_n = 0.3\text{Hz to } 10\text{Hz}$ $f_n = 0.3\text{Hz to } 10\text{Hz}$	5 4.5	3 20		*	*	μVrms pArms	$\mu\text{Vp-p}$ pAp-p
INPUT VOLTAGE RANGE Common-mode Voltage ⁽⁴⁾ Common-mode Rejection	Linear Operation $f = \text{DC}$, $V_{\text{CM}} = \pm(V_S - 6)$	$\pm(V_S - 6)$ 70	$\pm(V_S - 3)$ 110		*	*	80	V dB
POWER SUPPLY Rated Voltage Operating Voltage Range Current, quiescent		± 10	± 28 ± 2.6	± 36 ± 10	*	± 34 *	± 40 *	V V mA
TEMPERATURE RANGE Specification, RM, SM AM, BM Operating, derated performance, AM, BM Storage	case	-55 -25 -55 -65		+125 +85 +125 +150	*	*	*	$^\circ\text{C}$ $^\circ\text{C}$ $^\circ\text{C}$ $^\circ\text{C}$
THERMAL RESISTANCE	Steady State θ_{JC}		2.0	2.2		*	*	$^\circ\text{C}/\text{W}$

*Specification same as for OPA501RM, AM.

NOTES: (1) Package must be derated based on a junction-to-case thermal resistance of $2.2^\circ\text{C}/\text{W}$ or a junction-to-ambient thermal resistance of $30^\circ\text{C}/\text{W}$. (2) Safe Operating Area and Power Derating Curves must be observed. (3) With $\pm R_{\text{SC}} = 0$. Peak output current is typically greater than 10A if duty cycle and pulse width limitations are observed. Output current greater than 10A is not guaranteed. (4) The absolute maximum voltage is 3V less than supply voltage.

The information provided herein is believed to be reliable; however, BURR-BROWN assumes no responsibility for inaccuracies or omissions. BURR-BROWN assumes no responsibility for the use of this information, and all use of such information shall be entirely at the user's own risk. Prices and specifications are subject to change without notice. No patent rights or licenses to any of the circuits described herein are implied or granted to any third party. BURR-BROWN does not authorize or warrant any BURR-BROWN product for use in life support devices and/or systems.

ABSOLUTE MAXIMUM RATINGS

Power Supply Voltage (V_S)	$\pm 40V$
Power Dissipation at +25°C ^(1, 2)	79W
Differential Input Voltage	$\pm V_S - 3V$
Common-Mode Input Voltage	$\pm V_S$
Operating Temperature Range	-55°C to +125°C
Storage Temperature Range	-65°C to +150°C
Lead Temperature (soldering, 10s)	+300°C
Junction Temperature	+200°C
Output Short-Circuit Duration ⁽³⁾	Continuous

NOTES: (1) At case temperature of +25°C. Derate at 2.2°C/W above case temperature of +25°C. (2) Average dissipation. (3) Within safe operating area and with appropriate derating.

CONNECTION DIAGRAM

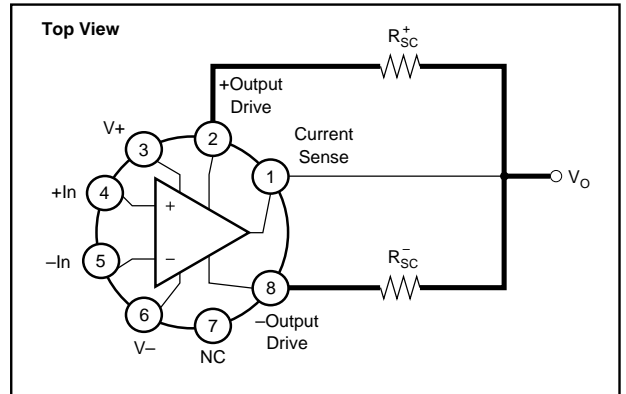

ORDERING INFORMATION

MODEL	PACKAGE	TEMPERATURE RANGE
OPA501AM	8-Pin Metal TO-3	-25°C to +85°C
OPA501BM	8-Pin Metal TO-3	-25°C to +85°C
OPA501RM	8-Pin Metal TO-3	-55°C to +125°C
OPA501SM	8-Pin Metal TO-3	-55°C to +125°C

PACKAGE INFORMATION

MODEL	PACKAGE	PACKAGE DRAWING NUMBER ⁽¹⁾
OPA501AM	8-Pin Metal TO-3	030
OPA501BM	8-Pin Metal TO-3	030
OPA501RM	8-Pin Metal TO-3	030
OPA501SM	8-Pin Metal TO-3	030

NOTE: (1) For detailed drawing and dimension table, please see end of data sheet, or Appendix D of Burr-Brown IC Data Book.

TYPICAL PERFORMANCE CURVES

Typical at +25°C case and $\pm V_s = 28\text{VDC}$, unless otherwise noted.

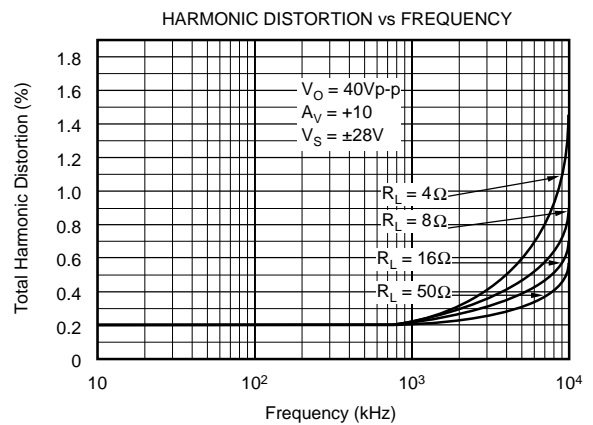
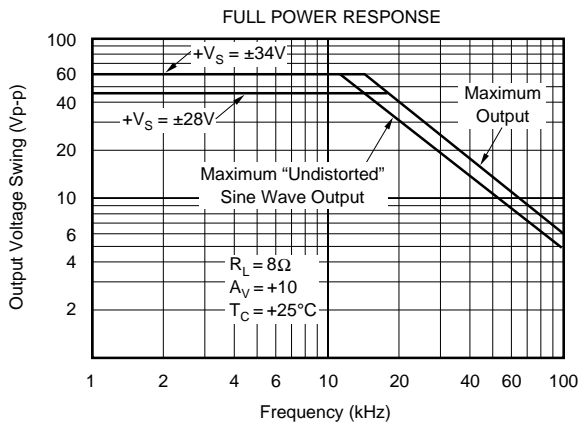
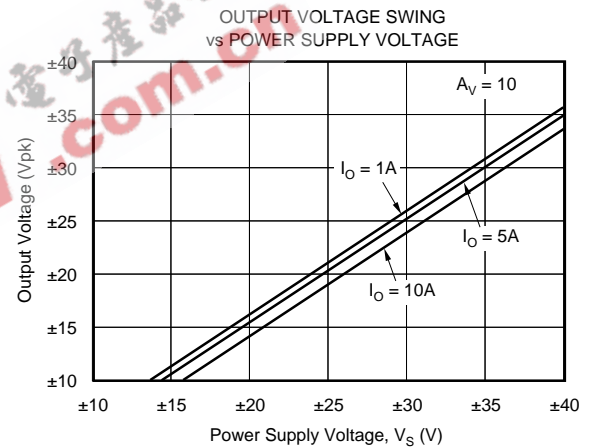
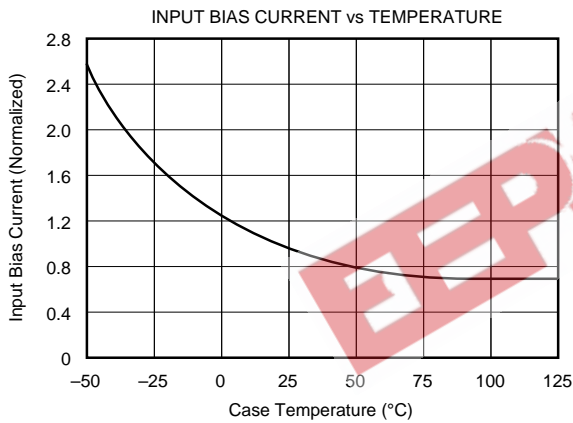
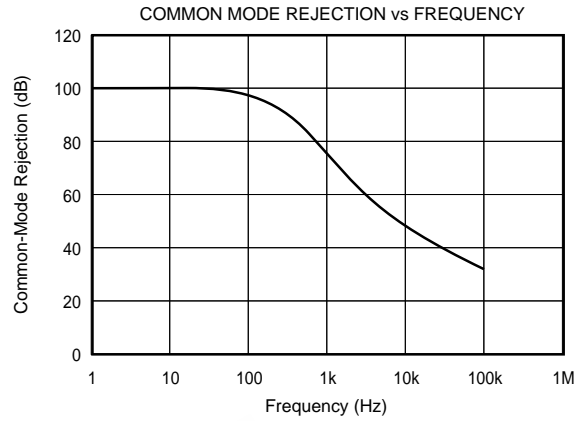
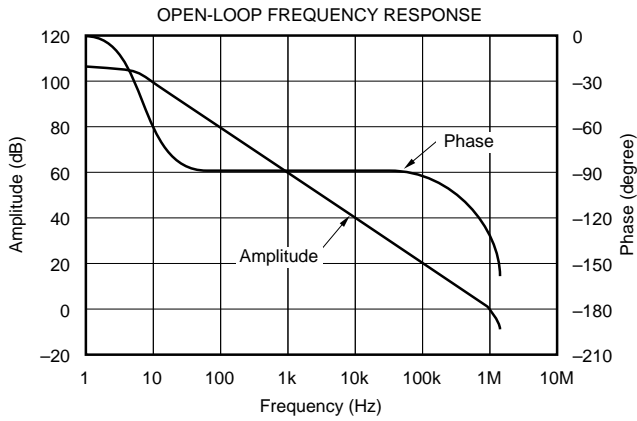

TYPICAL PERFORMANCE CURVES (CONT)

Typical at +25°C case and $\pm V_S = 28\text{VDC}$, unless otherwise noted.

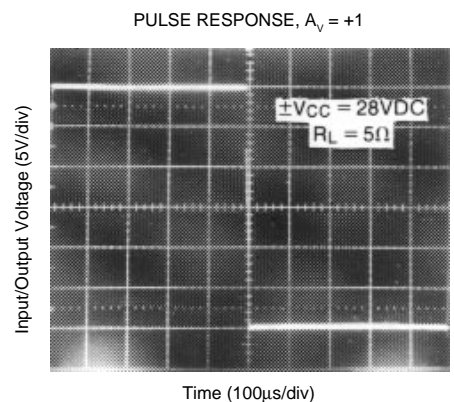
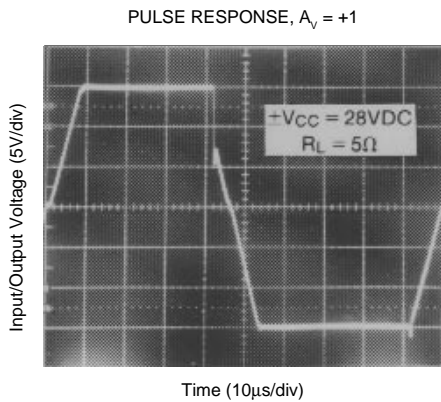
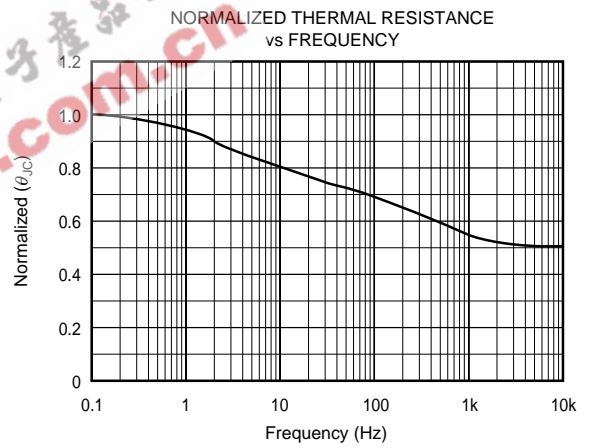
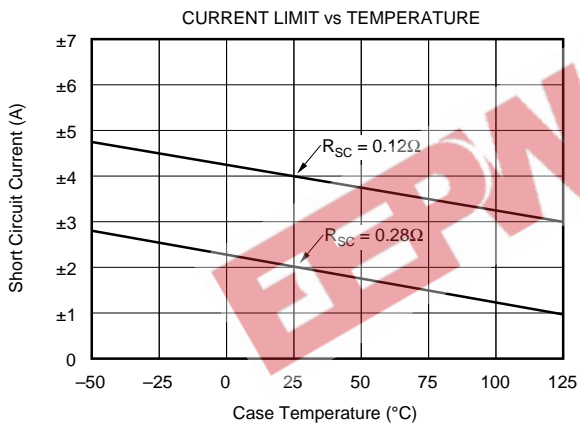
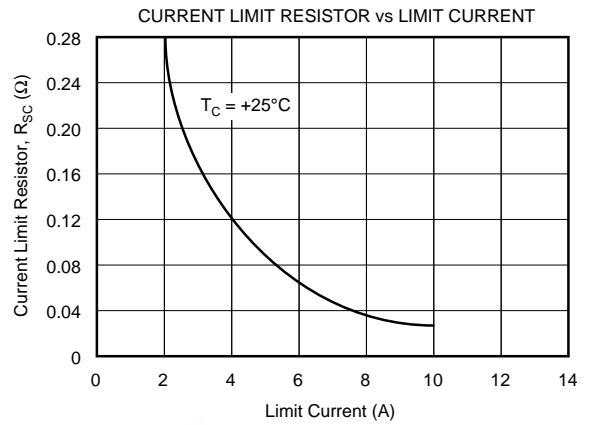
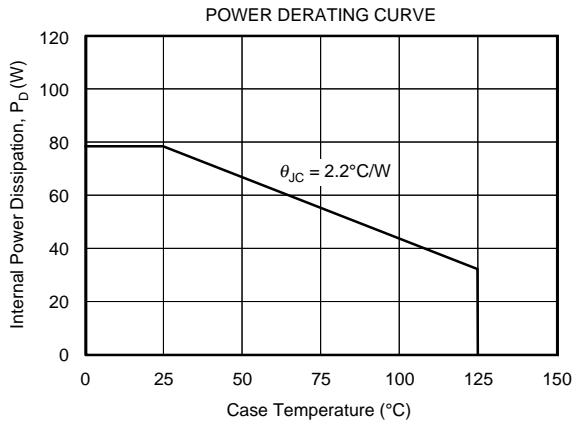

APPLICATIONS INFORMATION

Grounding techniques can greatly affect the performance of a power op amp. Figure 1 shows grounds connected so that load current does not flow through signal ground connections. Power supply and load connections should be physically separated from the amplifier input and signal connections.

Power supply connections to the amplifier should be bypassed with 10 μ F tantalum capacitors connected close to the device pins. The capacitors should be connected to load ground as shown.

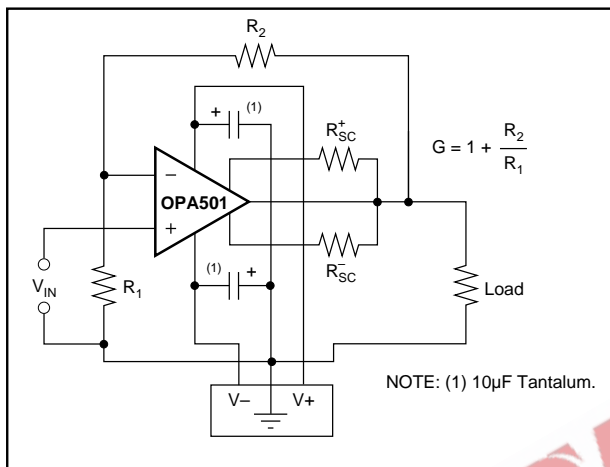

FIGURE 1. Basic Circuit Connections.

CURRENT LIMITS

The OPA501 has independent positive and negative current limit circuits. Current limits are set by the value of R_{SC+} and R_{SC-} . The approximate value of these resistors is:

$$R_{SC} = \frac{0.65}{I_{LIMIT}} - 0.0437\Omega$$

I_{LIMIT} is the desired maximum current at room temperature in Amperes and R_{SC} is in ohms. The current limit value decreases with increasing temperature—see typical performance curves. The current limit resistors conduct the full amplifier output current. Power dissipation of the current limit resistors at maximum current is:

$$P_{MAX} = (I_{LIMIT})^2 R_{SC}$$

The current limit resistors can be chosen from a variety of types. Most wire-wound types are satisfactory, although some physically large resistors may have excessive inductance which can cause instability.

SAFE OPERATING AREA

Stress on the output transistor is determined by the output current and the voltage across the conducting output transistor. The power dissipated by the output transistor is equal to the product of the output current and the voltage across the conducting transistor, V_{CE} . The Safe Operating Area (SOA),

Figure 2, shows the permissible range of voltage and current. SOA is reduced at high operating temperature—see Figure 3.

The safe output current decreases as V_{CE} increases. Output short-circuits are very demanding. A short-circuit to ground forces the full power supply voltage (positive or negative side) across the conducting transistor. With $V_S = \pm 30V$, the current limit must be set for 2A to be safe for short-circuit to ground. For further information on SOA and evaluating signal and load conditions, consult Applications Bulletin AB-039.

HEAT SINKING

Most applications require a heat sink to assure that the maximum junction temperature of 200°C is not exceeded. The size of the heat sink required depends on the power dissipated by the amplifier and ambient temperature conditions. Application Bulletin AB-039 explains how to find maximum power dissipation for DC, AC, reactive loads, and other conditions. Applications Bulletin AB-038 shows how to determine heat sink requirements.

The case of the OPA501 is isolated from all circuitry and can be fastened directly to a heat sink. This eliminates cumbersome insulating hardware that degrades thermal performance. See Applications Bulletin AB-037 for information on mounting techniques and procedures.

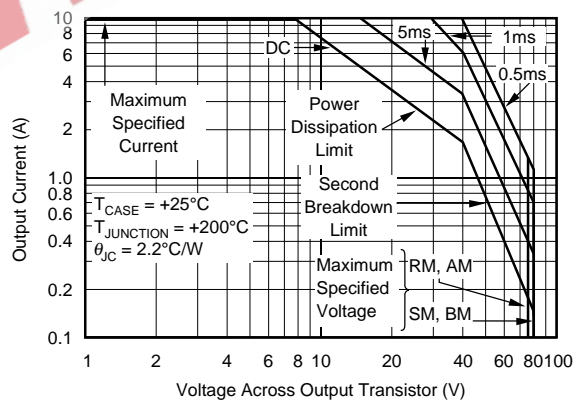

FIGURE 2. Transistor Safe Operating Area at +25°C Case Temperature.

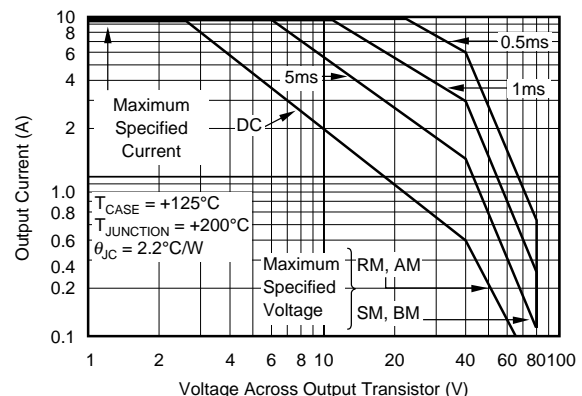

FIGURE 3. Transistor Safe Operating Area at +125°C Case Temperature.