

OPA633

High Speed BUFFER AMPLIFIER

FEATURES

- WIDE BANDWIDTH: 260MHz
- HIGH SLEW RATE: 2500V/ μ s
- HIGH OUTPUT CURRENT: 100mA
- LOW OFFSET VOLTAGE: 1.5mV
- REPLACES HA-5033
- IMPROVED PERFORMANCE/PRICE:
LH0033, LTC1010, H0S200

APPLICATIONS

- OP AMP CURRENT BOOSTER
- VIDEO BUFFER
- LINE DRIVER
- A/D CONVERTER INPUT BUFFER

DESCRIPTION

The OPA633 is a monolithic unity-gain buffer amplifier featuring very wide bandwidth and high slew rate. A dielectric isolation process incorporating both NPN and PNP high frequency transistors achieves performance unattainable with conventional integrated circuit technology. Laser trimming provides low input offset voltage.

High output current capability allows the OPA633 to drive 50 Ω and 75 Ω lines, making it ideal for RF, IF and video applications. Low phase shift allows the OPA633 to be used inside amplifier feedback loops. OPA633 is available in a low cost plastic DIP package specified for 0°C to +75°C operation.

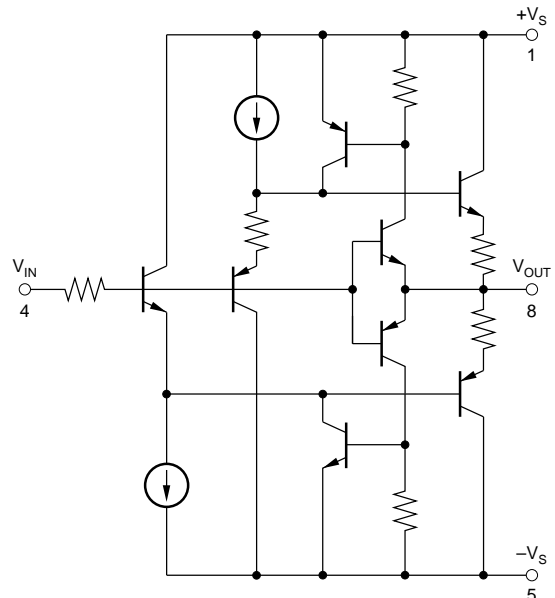

SPECIFICATIONS

ELECTRICAL

At +25°C, $V_S = \pm 12V$, $R_S = 50\Omega$, $R_L = 100\Omega$, and $C_L = 10pF$, unless otherwise specified.

PARAMETER	CONDITIONS	OPA633KP			UNITS
		MIN	TYP	MAX	
FREQUENCY RESPONSE					
Small Signal Bandwidth	$V_O = 1V_{rms}$, $R_L = 1k\Omega$ $V_O = 10V$, $V_S = \pm 15V$, $R_L = 1k\Omega$ $V_O = 500mV$		260		MHz
Full Power Bandwidth			40		MHz
Slew Rate		1000	2500		V/ μs
Rise Time, 10% to 90%			2.5		ns
Propagation Delay			1		ns
Overshoot			10		%
Settling Time, 0.1%			50		ns
Differential Phase Error ⁽¹⁾			0.1		Degrees
Differential Gain Error ⁽¹⁾			0.1		%
Total Harmonic Distortion		$V_O = 1V_{rms}$, $R_L = 1k\Omega$, $f = 100kHz$ $V_O = 1V_{rms}$, $R_L = 100\Omega$, $f = 100kHz$		0.005 0.02	
OUTPUT CHARACTERISTICS					
Voltage	$T_A = T_{MIN}$ to T_{MAX} $R_L = 1k\Omega$, $V_S = \pm 15V$	± 8	± 10		V
Current		± 11	± 13		V
Resistance		± 80	± 100		mA
			5		Ω
TRANSFER CHARACTERISTICS					
Gain	$R_L = 1k\Omega$ $T_A = T_{MIN}$ to T_{MAX}	0.93	0.95 0.99 0.95		V/V V/V V/V
INPUT					
Offset Voltage	$T_A = +25^\circ C$ $T_A = T_{MIN}$ to T_{MAX}		± 5 ± 6	± 15 ± 25	mV mV
vs Temperature			± 33		$\mu V/^\circ C$
vs Supply	$T_A = T_{MIN}$ to T_{MAX}	54	72		dB
Bias Current	$T_A = +25^\circ C$ $T_A = T_{MIN}$ to T_{MAX}		± 15 ± 20	± 35 ± 50	μA μA
Noise Voltage	10Hz to 1MHz		20		$\mu Vp-p$
Resistance			1.5		M Ω
Capacitance			1.6		pF
POWER SUPPLY					
Rated Supply Voltage	Specified Performance		± 12		V
Operating Supply Voltage	Derated Performance	± 5		± 16	V
Current, Quiescent	$I_O = 0$ $I_O = 0$, $T_A = T_{MIN}$ to T_{MAX}		21 21	25 30	mA mA
TEMPERATURE RANGE					
Specification, Ambient		0		+75	$^\circ C$
Operating, Ambient		-25		+85	$^\circ C$
θ Junction, Ambient			90		$^\circ C/W$

NOTE: (1) Differential phase error in video transmission systems is the change in phase of a color subcarrier resulting from a change in picture signal from blanked to white. Differential gain error is the change in amplitude at the color subcarrier frequency resulting from a change in picture signal from blanked to white.

PIN CONFIGURATION

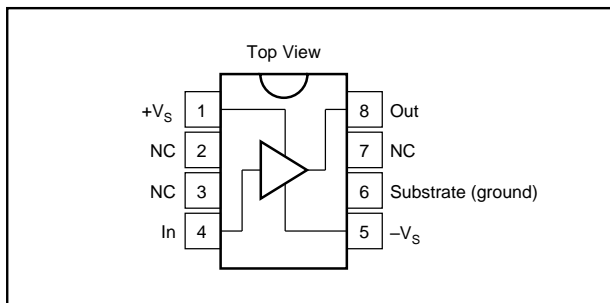

ABSOLUTE MAXIMUM RATINGS

Power Supply, $\pm V_S$	$\pm 20V$
Input Voltage V_{IN}	$+V_S + 2V$ to $-V_S - 2V$
Output Current (peak)	$\pm 200mA$
Internal Power Dissipation (25°C)	1.95W
Junction Temperature	200°C
Storage Temperature Range	-40°C to +85°C
Lead Temperature (soldering, 10s)	300°C

PACKAGE INFORMATION⁽¹⁾

MODEL	PACKAGE	PACKAGE DRAWING NUMBER
OPA633KP	8-Pin Plastic DIP	006

NOTE: (1) For detailed drawing and dimension table, please see end of data sheet, or Appendix D of Burr-Brown IC Data Book.

ORDERING INFORMATION

MODEL	PACKAGE	TEMPERATURE RANGE
OPA633KP	8-Pin Plastic DIP	0°C to +75°C



OPA633

TYPICAL PERFORMANCE CURVES

At +25°C, $V_S = \pm 12V$, $R_S = 50\Omega$, $R_L = 100\Omega$, and $C_L = 10pF$, unless otherwise specified.

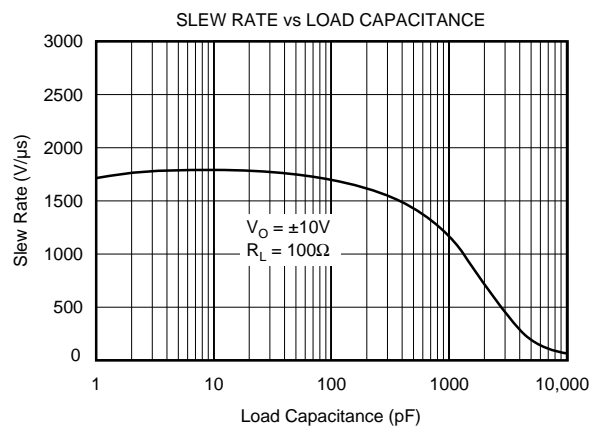
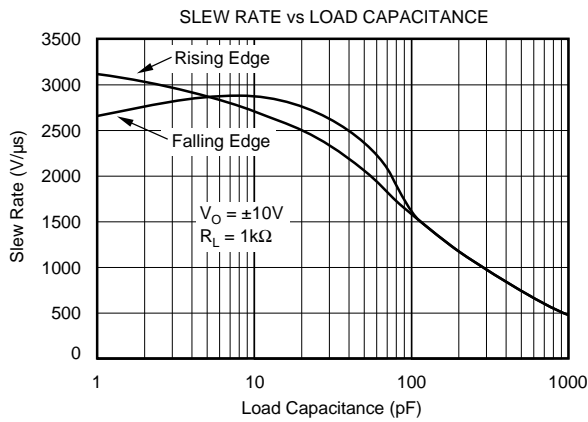
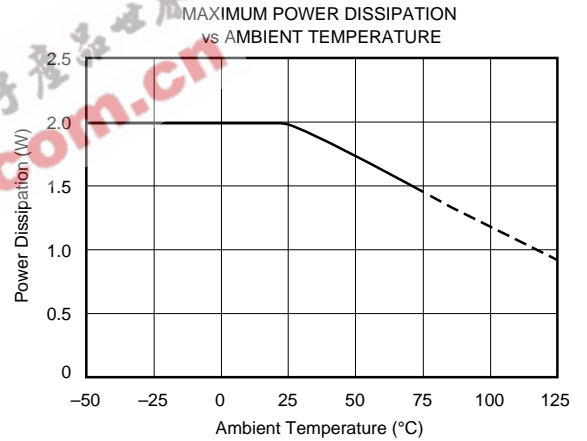
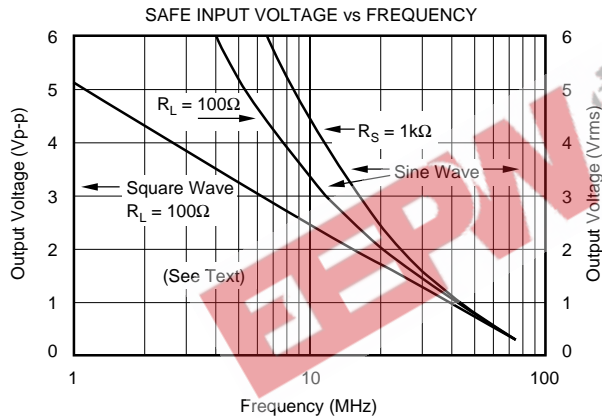
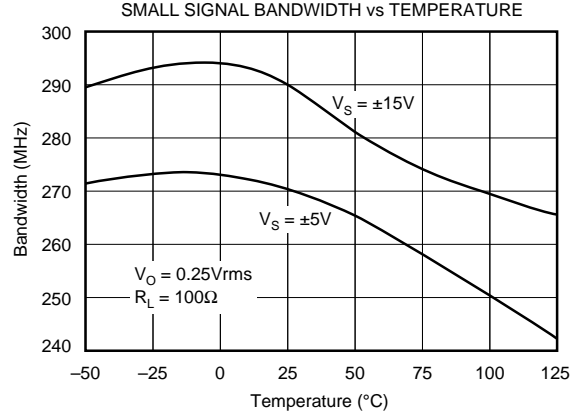
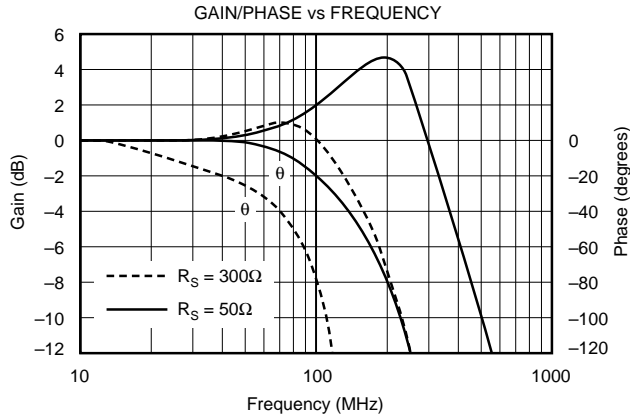

TYPICAL PERFORMANCE CURVES (CONT)

At +25°C, $V_S = \pm 12V$, $R_S = 50\Omega$, $R_L = 100\Omega$, and $C_L = 10pF$, unless otherwise specified.

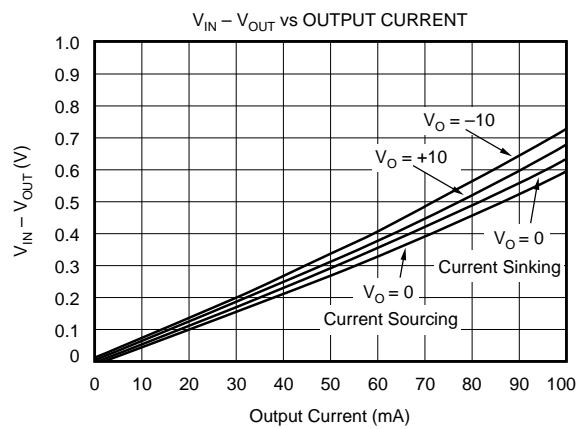
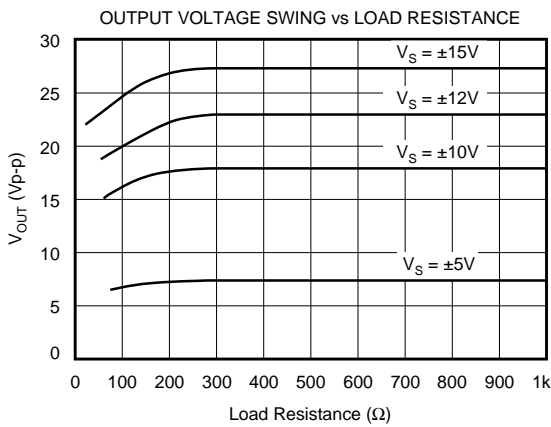
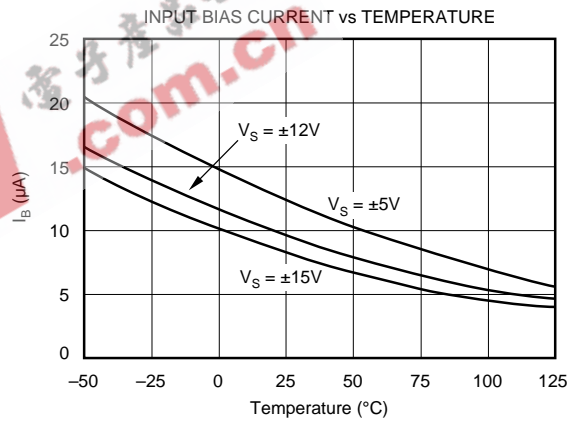
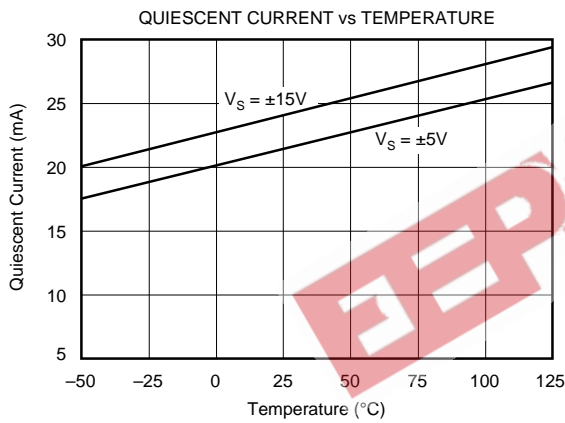
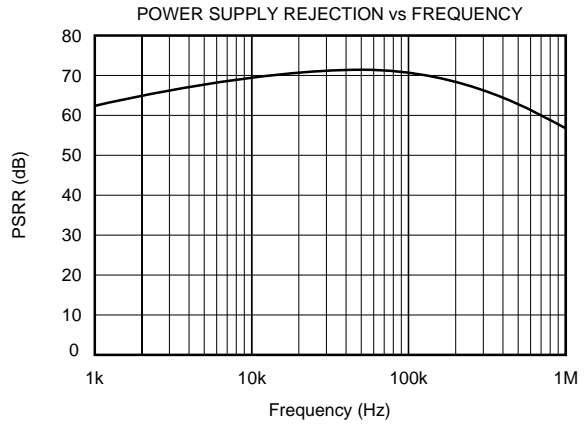
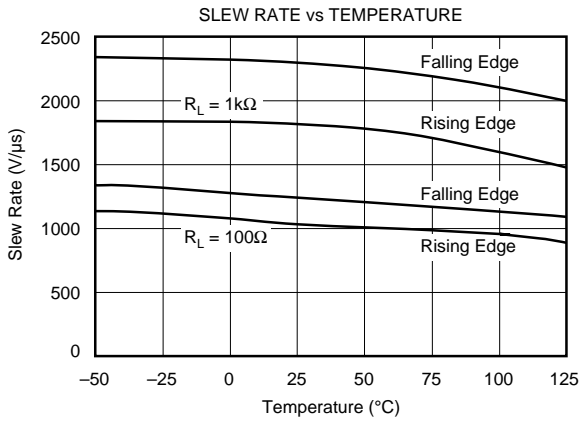

TYPICAL PERFORMANCE CURVES (CONT)

At +25°C, $V_S = \pm 12V$, $R_S = 50\Omega$, $R_L = 100\Omega$, and $C_L = 10pF$, unless otherwise specified.

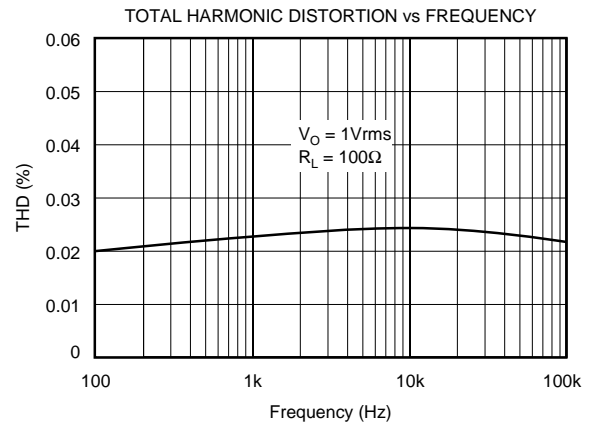
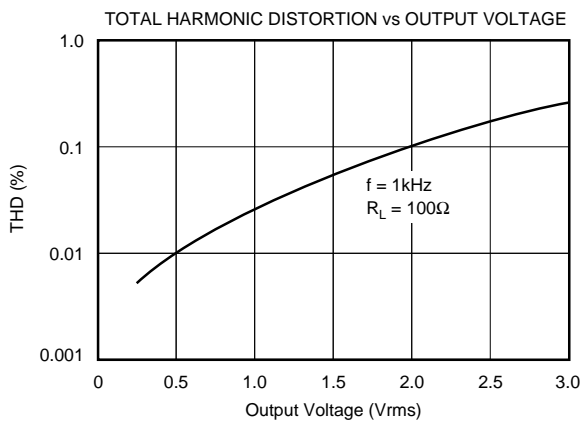
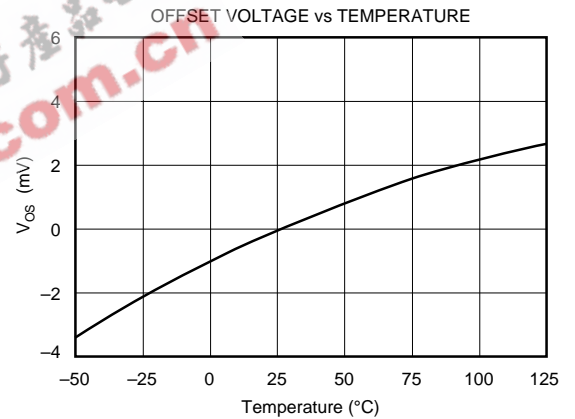
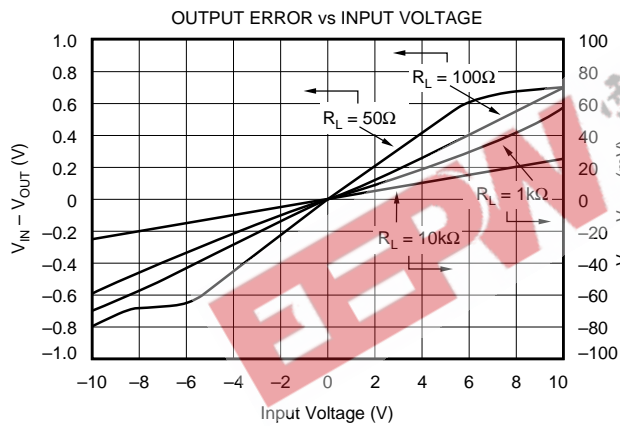
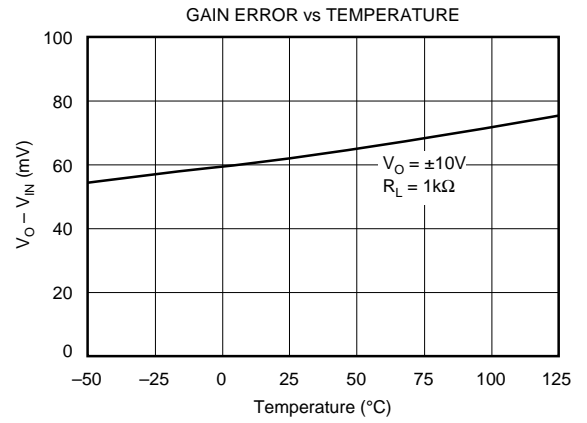
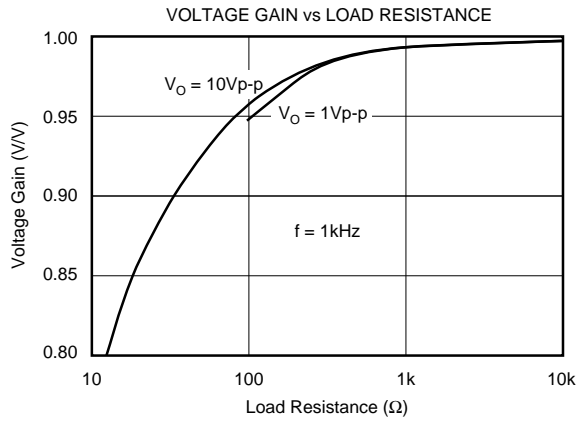

APPLICATIONS INFORMATION

As with any high frequency circuitry, good circuit layout technique must be used to achieve optimum performance. Power supply connections must be bypassed with high frequency capacitors. Many applications benefit from the use of two capacitors on each power supply—a ceramic capacitor for good high frequency decoupling and a tantalum type for lower frequencies. They should be located as close as possible to the buffer's power supply pins. A large ground plane is used to minimize high frequency ground drops and stray coupling.

Pin 6 connects to the substrate of the integrated circuit and should be connected to ground. In principle it could also be connected to $+V_s$ or $-V_s$, but ground is preferable. The additional lead length and capacitance associated with sockets may cause problems in applications requiring the highest fidelity of high speed pulses.

Depending on the nature of the input source impedance, a series input resistor may be required for best stability. This behavior is influenced somewhat by the load impedance (including any reactive effects). A value of 50Ω to 200Ω is typical. This resistor should be located close to the OPA633's input pin to avoid stray capacitance at the input which could reduce bandwidth (see Gain and Phase versus Frequency curve).

OVERLOAD CONDITIONS

The input and output circuitry of the OPA633 are not protected from overload. When the input signal and load characteristics are within the device's capabilities, no protection circuitry is required. Exceeding device limits can result in permanent damage.

The OPA633's small package and high output current capability can lead to overheating. The internal junction temperature should not be allowed to exceed 150°C . Although failure is unlikely to occur until junction temperature exceeds 200°C , reliability of the part will be degraded significantly at such high temperatures. Since significant heat transfer takes place through the package leads, wide printed circuit traces to all leads will improve heat sinking. Sockets reduce heat transfer significantly and are not recommended.

Junction temperature rise is proportional to internal power dissipation. This can be reduced by using the minimum supply voltage necessary to produce the required output voltage swing. For instance, 1V video signals can be easily handled with $\pm 5\text{V}$ power supplies thus minimizing the internal power dissipation.

Output overloads or short circuits can result in permanent damage by causing excessive output current. The 50Ω or 75Ω series output resistor used to match line impedance will, in most cases, provide adequate protection. When this resistor is not used, the device can be protected by limiting the power supply current. See "Protection Circuits."

Excessive input levels at high frequency can cause increased internal dissipation and permanent damage. See the safe

input voltage versus frequency curves. When used to buffer an op amp's output, the input to the OPA633 is limited, in most cases, by the op amp. When high frequency inputs can exceed safe levels, the device must be protected by limiting the power supply current.

PROTECTION CIRCUITS

The OPA633 can be protected from damage due to excessive currents by the simple addition of resistors in series with the power supply pins (Figure 5a). While this limits output current, it also limits voltage swing with low impedance loads. This reduction in voltage swing is minimal for AC or high crest factor signals since only the average current from the power supply causes a voltage drop across the series resistor. Short duration load-current peaks are supplied by the bypass capacitors.

The circuit of Figure 5b overcomes the limitations of the previous circuit with DC loads. It allows nearly full output voltage swing up to its current limit of approximately 140mA. Both circuits require good high frequency capacitors (e.g., tantalum) to bypass the buffer's power supply connections.

CAPACITIVE LOADS

The OPA633 is designed to safely drive capacitive loads up to $0.01\mu\text{F}$. It must be understood, however, that rapidly changing voltages demand large output load currents:

$$I_{\text{LOAD}} = C_{\text{LOAD}} \frac{dV}{dt}$$

Thus, a signal slew rate of $1000\text{V}/\mu\text{s}$ and load capacitance of $0.01\mu\text{F}$ demands a load current of 10A. Clearly maximum slew rates cannot be combined with large capacitive loads. Load current should be kept less than 100mA continuous (200mA peak) by limiting the rate of change of the input signal or reducing the load capacitance.

USE INSIDE A FEEDBACK LOOP

The OPA633 may be used inside the feedback path of an op amp such as the OPA602. Higher output current is achieved without degradation in accuracy. This approach may actually improve performance in precision applications by removing load-dependent dissipation from a precision op amp. All vestiges of load-dependent offset voltage and temperature drift can be eliminated with this technique. Since the buffer is placed within the feedback loop of the op amp, its DC errors will have a negligible effect on overall accuracy. Any DC errors contributed by the buffer are divided by the loop gain of the op amp.

The low phase shift of the OPA633 allows its use inside the feedback loop of a wide variety of op amps. To assure stability, the buffer must not add significant phase shift to the loop at the gain crossing frequency of the circuit—the frequency at which the open loop gain of the op amp is equal to the closed loop gain of the application. The OPA633 has a typical phase shift of less than 10° up to 70MHz, thus making it useful even with wideband op amps.

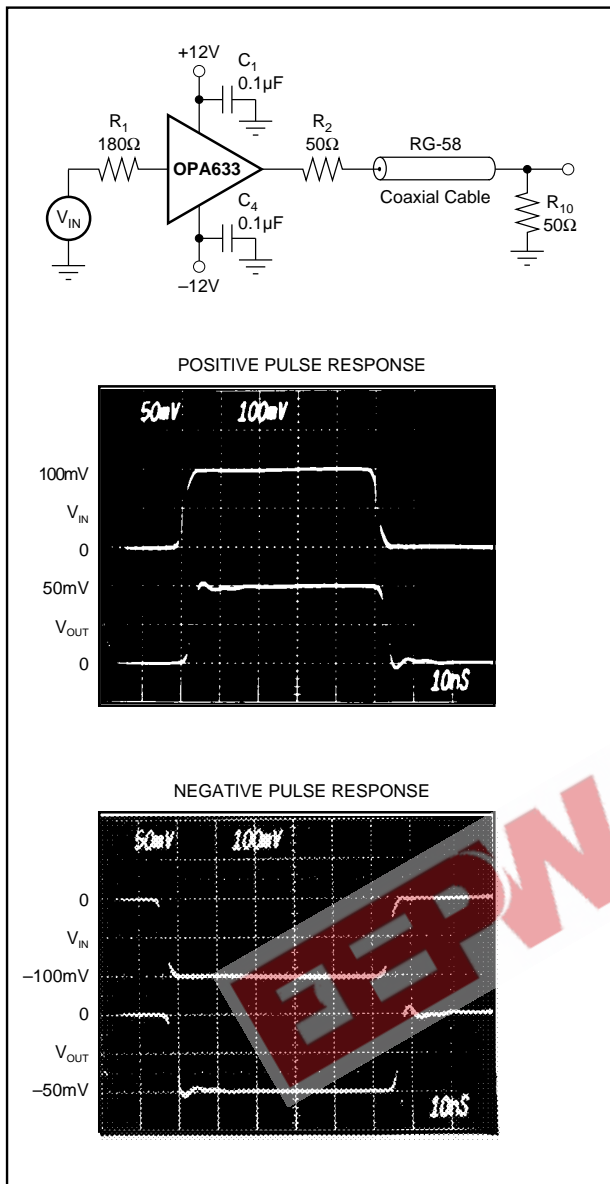

FIGURE 1. Coaxial Cable Driver Circuit.

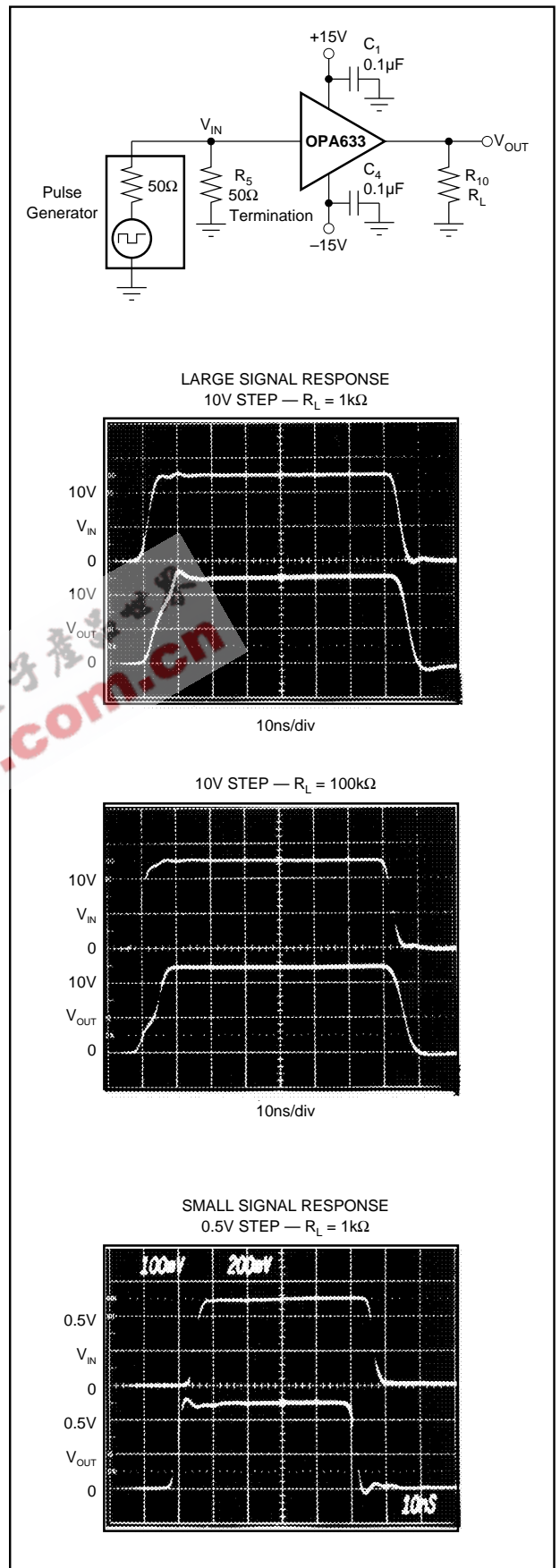

FIGURE 2. Dynamic Response Test Circuit.

