



INSTRUCTION MANUAL

VHF MARINE TRANSCEIVER

IC-M59

電子產品世界
EPW.com.cn

Icom Inc.

IN CASE OF EMERGENCY

If your vessel requires assistance, contact other vessels and the Coast Guard by sending a distress call on channel 16.

○ **USING CHANNEL 16**

DISTRESS CALL PROCEDURE

1. "MAYDAY MAYDAY MAYDAY"
2. "THIS IS -----" (name of vessel)
3. Your call sign or other indication of the vessel (AND 9-digit DSC ID if you have one).
4. "LOCATED AT -----" (your position)
5. The nature of the distress and assistance required.
6. Any other information which might facilitate the rescue.

Or, transmit your distress call using digital selective calling on channel 70 (the optional UX-120 DSC UNIT must be installed).

○ **USING DIGITAL SELECTIVE CALLING (ch 70)** (UX-120 required)

DISTRESS CALL PROCEDURE

1. Push and hold [16•EMER] for 5 sec. until you hear 5 short beeps change to one long beep.
2. Then, push [PTT] to transmit the call.
3. Wait for an acknowledgment from a coast station.
 - When received, channel 16 is automatically selected.
4. Push and hold [PTT], then transmit the appropriate information as at left.

TABLE OF CONTENTS

IN CASE OF EMERGENCY	i		
TABLE OF CONTENTS	ii		
IMPORTANT	iii		
CAUTIONS.....	iii		
1 OPERATING RULES	1		
2 PANEL DESCRIPTION	2 – 5		
■ Front panel	2		
■ Microphone	3		
■ Function display	4		
3 BASIC OPERATION	6 – 11		
■ Power ON	6		
■ Channel selection	6		
■ Receiving	8		
■ Transmitting	9		
■ Scan function	10		
■ Call channel programming	11		
■ Display backlighting	11		
4 DIGITAL SELECTIVE CALLING	12 – 18		
■ General	12		
■ Distress call transmission	13		
■ All ships call transmission	14		
■ Individual call transmission	15		
■ Receiving DSC calls	16		
5 SET MODE	19 – 21		
■ Entering SET mode	19		
■ SET mode items	19		
6 CONNECTIONS AND MAINTENANCE	22 – 27		
■ Unpacking	22		
■ Additional requirements	22		
■ Connections	23		
■ Mounting the transceiver	24		
■ Dimensions	25		
■ Antenna	26		
■ Fuse replacement	26		
■ Cleaning	26		
■ Optional unit installations	26		
7 TROUBLESHOOTING	28		
8 VHF MARINE CHANNEL LIST	29		
9 SPECIFICATIONS	30		
10 OPTIONS	31		

IMPORTANT

READ ALL INSTRUCTIONS carefully and completely before using the transceiver.

SAVE THIS INSTRUCTION MANUAL—This instruction manual contains important operating instructions for the IC-M59.

YOU MUST HAVE a DSC vessel ID in order to operate the optional DSC functions of the transceiver. See your Dealer for details.

CAUTIONS

⚠ WARNING NEVER connect the transceiver to an AC outlet. This may pose a fire hazard or result in an electric shock.

⚠ WARNING HIGH VOLTAGE! NEVER touch the antenna or an internal antenna connector during transmission. This may result in an electric shock or a burn.

NEVER connect the transceiver to a power source of more than 16 V DC. This connection will ruin the transceiver.

WHEN INSTALLING THE DSC UNIT

NEVER transmit a distress call when your vessel does not need immediate help. Distress calls can be used only in times of emergency.

AVOID using or placing the transceiver in direct sunlight or in areas with temperatures below -20°C (-4°F) or above $+60^{\circ}\text{C}$ ($+140^{\circ}\text{F}$).

DO NOT operate the transceiver without running the vessel's engine. When your vessel's engine is OFF and the transceiver is transmitting, the vessel's battery will soon become exhausted.

KEEP the transceiver out of the reach of children.

KEEP the antenna cable and DC power cable as far away as possible from electrical pumps, generators and other electronic instruments to prevent instrument malfunctions.

KEEP the transceiver and microphone at least 1 meter away from your vessel's magnetic navigation compass.

◇ Priorities

- Read all rules and regulations pertaining to priorities and keep an up-to-date copy handy. Safety and distress calls take priority over all others.
- You must monitor channel 16 when you are not operating on another channel.
- False or fraudulent distress calls are prohibited under law.

◇ Privacy

- Information overheard but not intended for you cannot lawfully be used in any way.
- Indecent or profane language is prohibited.

◇ Radio licenses

SHIP STATION LICENSE

When your craft is equipped with a VHF FM transceiver, you must have a current radio station license before using the transceiver. It is unlawful to operate a ship station which is not licensed.

Inquire through your dealer or the appropriate government agency for a Ship-Radiotelephone license. This license includes the call sign which is your craft's identification for radio purposes.

OPERATOR'S LICENSE

A restricted Radiotelephone Operator Permit is the license most often held by small vessel radio operators when a radio is not required for safety purposes.

The Restricted Radiotelephone Operator Permit must be posted near the transceiver or be kept with the operator. Only a licensed radio operator may operate a transceiver.

However, non-licensed individuals may talk over a transceiver if a licensed operator starts, supervises, ends the call and makes the necessary log entries.

A current copy of the applicable government rules and regulations is only required to be on hand for vessels in which a radio telephone is compulsory. However, even if you are not required to have these on hand it is your responsibility to be thoroughly acquainted with all pertinent rules and regulations.

■ Front panel

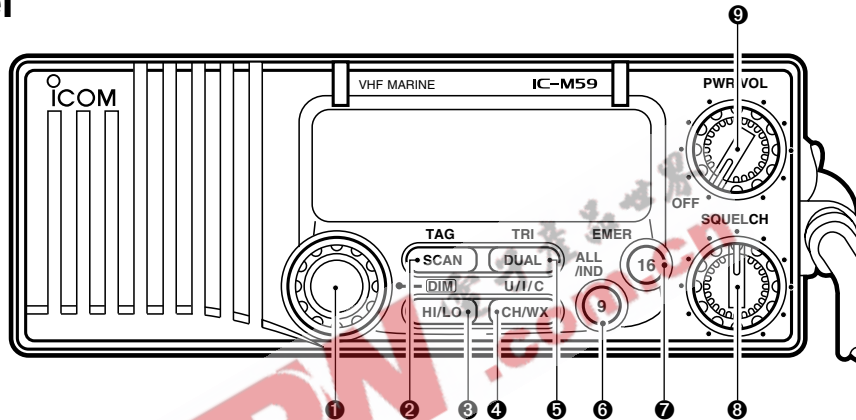

❶ CHANNEL SELECTOR [CHANNEL]

Selects an operating channel in the selected channel group.

❷ SCAN SWITCH [SCAN•TAG]

- Starts and stops normal or priority scan when tag channels are programmed. (p. 10)
- Push and hold for 1 sec. to toggle the tag setting for the displayed channel. (p. 10)

❸ HIGH/LOW POWER SWITCH [HI/LO•DIM]

- Toggles between high and low output powers. (p. 9)
- While pushing, rotate the channel selector to adjust the

display and control/switch backlighting intensity. (p. 11)

❹ CHANNEL/WEATHER CHANNEL SWITCH [CH/WX•U/I/C]

- Selects and toggles between regular and weather channels.
- Selects one of 3 regular channels in sequence when pushed for 1 sec. (p. 7)
 - ▣ International, U.S.A. and Canadian channels are available for regular channels.

❺ DUAL/TRI-WATCH SWITCH [DUAL•TRI] (p. 8)

- Activates dualwatch for checking channel 16.

- Push and hold for 1 sec. to activate tri-watch for checking channel 16 and the call channel.

⑥ CALL CHANNEL SWITCH [9•ALL/IND]

- Selects the call channel—the call channel is programmable, channel 9 being the default. (p. 11)
- Push and hold for 1 sec. to enter the standby condition of a DSC call. (When an optional UX-120 is installed). (pgs. 14, 15)
 - ⇒ Both “All ships call” and “Individual call” are selectable.

⑦ CHANNEL 16 SWITCH [16•EMER]

- Selects channel 16. (p. 6)
- Push and hold to enter the standby condition for a distress call transmission using the DSC function (when an optional UX-120 is installed). (p. 13)

⑧ SQUELCH CONTROL [SQUELCH]

- Rotate clockwise to eliminate audio noise. (p. 8)
- Activates the built-in attenuator when rotated deep clockwise. (p. 8)

⑨ POWER/VOLUME CONTROL [PWR/VOL]

Turns power ON and OFF and adjusts the audio output level. (p. 6)

■ Microphone

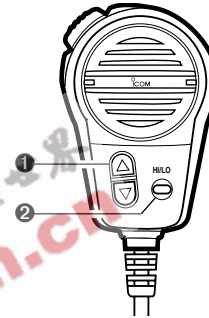

① CHANNEL UP/DOWN SWITCHES [▼]/[▲]

- Select an operating channel in the selected channel group.
 - ⇒ These switches can be used instead of the transceiver’s channel selector.

② HIGH/LOW POWER SWITCH [HI/LO]

- The same function as the transceiver’s front panel.
- Toggles between high and low output powers. (p. 9)
 - While pushing, push the [▼]/[▲] switches to adjust the display and control/switch backlighting intensity. (p. 11)

2 PANEL DESCRIPTION

■ Function display

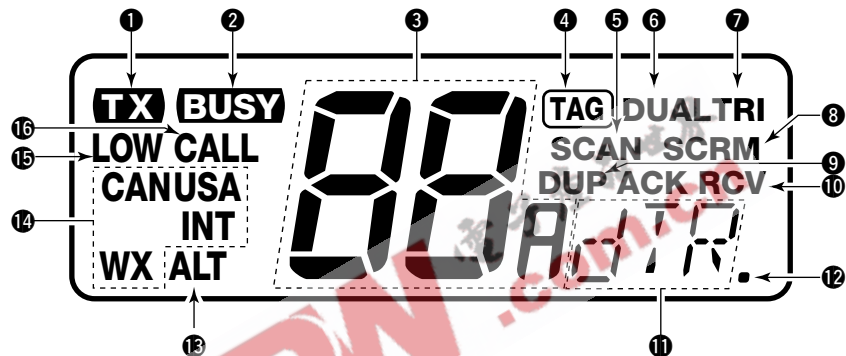

① TRANSMIT INDICATOR

Appears while transmitting. (p. 9)

② BUSY INDICATOR

Appears when receiving a signal or when [SQUELCH] is rotated too far counterclockwise. (p. 8)

③ CHANNEL INDICATOR

Shows the operating channel. (pgs. 6, 7)

④ TAG CHANNEL INDICATOR

Appears when the selected channel is set as a tag channel. (p. 10)

⑤ SCAN INDICATOR

Appears and flashes during scan operation. (p. 10)

⑥ DUALWATCH INDICATOR

Appears and flashes during dualwatch operation. (p. 8)

⑦ TRI-WATCH INDICATOR

Appears and flashes during tri-watch operation. (p. 8)

⑧ VOICE SCRAMBLER INDICATOR

Appears while the optional voice scrambler is activated. (p. 8)

9 DUPLEX INDICATOR

Appears when the selected channel is a duplex channel.

10 ACKNOWLEDGEMENT/RECEIVE INDICATORS

Appear during optional DSC operation. (pgs. 13–18)

- “RCV” appears when a DSC call is received.
- “ACK RCV” appears when an acknowledgement is received.
- “ACK” and “**T X**” appear when transmitting an acknowledgement.

11 DSC INDICATORS (pgs. 13–18)

Appear during optional DSC operation and show a format specifier, message, etc.

12 NMEA INDICATOR

Appears when NMEA devices (such as a GPS receiver) are connected. (p. 12)

13 WEATHER ALERT INDICATOR

Indicates the weather alert function is activated. (p. 7)

14 MODE INDICATORS (p. 7)

- “USA” shows USA channels are selected.
- “CAN” shows Canadian channels are selected.
- “INT” shows International channels are selected.
- “WX” shows weather channels are selected.

15 LOW POWER INDICATOR

Shows that low output power is selected. (p. 9)

16 CALL CHANNEL INDICATOR

Appears when the call channel is selected. (p. 6)

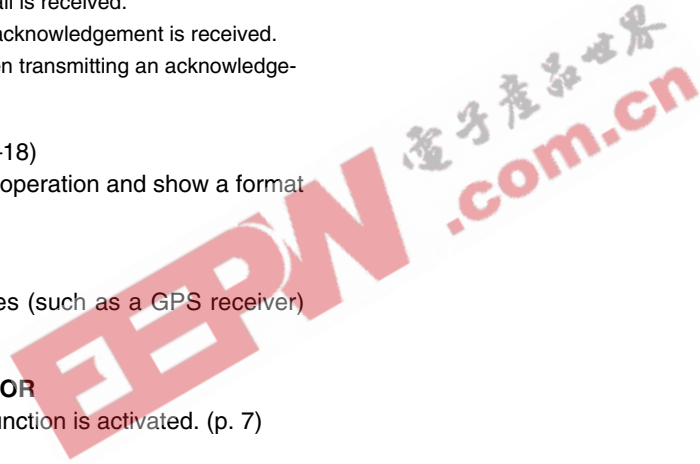

■ Power ON

- ① Rotate [PWR/VOL] clockwise to turn power ON.



All display indications appear briefly*.

*"SCRM" appears only when an optional UT-79 is installed.

"dSC" appears only when an optional UX-120 is installed.

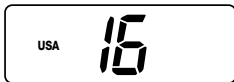

- ② Operate the transceiver as indicated in the following sections.

◇ Low voltage indicator

When "b" appears and flashes as shown at right, there is a DC power source problem. In this case, check your vessel's battery and DC power cable.



■ Channel selection

◇ Channel 16

Channel 16 is the distress channel. It is used for establishing initial contact with another station and for emergency communications. Channel 16 is monitored during dualwatch/tri-watch. While standing by you are required to monitor channel 16.

Push



or hang the microphone on the microphone hanger.

◇ Call channel

The call channel is used to store your most often-used channel for quick recall. In addition, the call channel is monitored during tri-watch. The default setting for the call channel is channel 9 which is for pleasure use.

Push



"CALL" indicates that the call channel is selected.

◇ **U.S.A., Canadian and international channels**

There are 61 U.S.A., 57 Canadian and 57 international channels. These channel groups may be specified for the operating area.

- ① Push [CH/WX] to select a regular channel.
 - If a weather channel appears, push [CH/WX] again.
- ② Rotate the channel selector to select a channel.
 - “DUP” appears for duplex channels.
- ③ To change the channel group, push [CH/WX•U/I/C] for 1 sec.
 - U.S.A., Canadian and international channels can be selected in sequence.

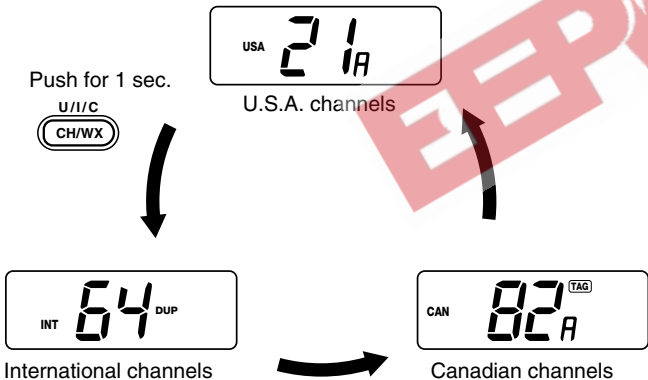

◇ **Weather channels**

There are 10 weather channels. These are used for monitoring NOAA (National Oceanographic and Atmospheric Administration) weather broadcasts.

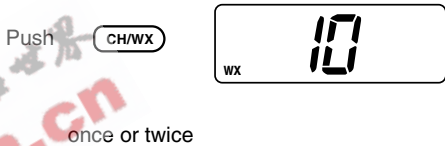

✓ **CONVENIENT**

Weather alert function: NOAA broadcast stations transmit a weather alert tone before an important weather announcement.

When the weather alert function is turned ON, the “ALT” indicator flashes until any key is pushed. This function is activated when a weather channel is selected or during any scan. See “SET mode items” on p. 19.

3 BASIC OPERATION

■ Receiving

- ① Rotate [PWR/VOL] to turn power ON.
- ② Rotate [SQUELCH] fully counterclockwise.
- ③ Adjust [PWR/VOL] to a suitable listening level.
- ④ Rotate [SQUELCH] clockwise until the audio noise disappears.
- ⑤ Select the desired channel. See pgs. 6–7 for details.
 - When a signal is received:
 - ▶ The squelch opens;
 - ▶ Audio is emitted from the speaker;
 - ▶ “BUSY” appears in the function display.
- ⑥ When an interrupting signal is received; rotate [SQUELCH] deeply clockwise.

◇ Voice scrambler function

For confidential communications, use the optional voice scrambler function. All members of your group must have the UT-79 VOICE SCRAMBLER UNIT installed in order to communicate using this function.

- ▶ While pushing [HI/LO], push [CH/WX] to toggle the function ON and OFF.
- “SCRM” appears when the function is ON.
 - This function cannot be used on CH 16.
 - Set the scramble code in SET mode in advance (p. 19).

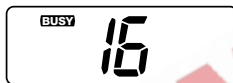

◇ Dual/tri-watch functions

These functions allow you to conveniently check the distress channel (ch 16) or, both the distress and pleasure call channel (ch 9; programmable) while receiving another channel. When receiving a signal on one of these channels, the transceiver stops on the channel until the signal disappears.

- ▶ Push [DUAL•TRI] momentarily for dualwatch.



Checking channel 16 every 2 sec.

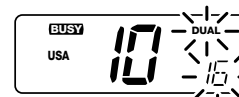

When receiving a signal on channel 16, channel 16 is monitored until the signal disappears.

- ▶ Push and hold [DUAL•TRI] for tri-watch.



Checking channel 16 and the call channel every 2 sec.



When receiving a signal on the call channel, the call channel is monitored while checking ch 16 in 2 sec. intervals.

When receiving a signal on channel 16, channel 16 has priority.



■ Transmitting

Before transmitting, read the call procedures at right.

- ① Select an operating channel. See pgs. 6, 7 for details.
- ② Push [HI/LO] to select transmit output power.
 - “LOW” appears when low output power is selected.
 - High power cannot be selected on some channels. Refer to the channel list on p. 29.
- ③ Push and hold the PTT switch to transmit.
 - “TX” appears.
- ④ Speak into the microphone at your normal voice level.
 - Do not hold the microphone too closely to your mouth or speak too loudly. This may distort the transmit signal.
- ⑤ Release the PTT switch to receive.

IMPORTANT: In order to maximize the readability of your transmitted signal, pause for a moment after pushing [PTT], hold the microphone 15–20 cm from your mouth, then speak into the microphone at an even, normal voice level.

MOMENTARY HIGH POWER

On U.S.A. channels 13, 15 and 67, transmission using high power is momentarily possible. To use high power, push and hold [HI/LO] while transmitting.

CALL PROCEDURES

You must identify yourself when you transmit and you must respect time limits.

- 1) Give your call sign each time you call another vessel or a coast station. If you have no call sign, identify the station by giving the vessel name and the name of the license.
- 2) Give your call sign at the end of each transmission that lasts more than 3 minutes.
- 3) You must pause and give your call sign at least once every 15 minutes during long ship-to-shore calls.
- 4) Keep your calls short (less than 3 minutes). Wait 2 minutes before repeating a call.
- 5) Unnecessary transmissions are not allowed.

TIME-OUT TIMER (U.S.A. version only)

The transceiver has a time-out timer function to prevent continuous, long transmissions. Transmit is automatically inhibited after 5 min. of continuous transmission.

3 BASIC OPERATION

■ Scan function

The transceiver has a high speed scan function for standing by on utility signals. The scan speed is 8 channels/sec. (except when the weather alert function is in use).

Two scan types are available: *normal scan* (scans all tag channels in sequence) and *priority scan* (checks channel 16 while scanning). These scans can be selected in set mode (p. 19).

◇ Setting tag channels

You can specify channels as tag channels for efficient scanning. Tag channels can be set for each channel group (USA, CAN, INT) independently.

- Select the desired channel, then push and hold [SCAN•TAG] for 1 sec. to toggle the tag setting.

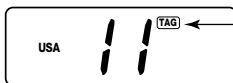

Appears when the channel is specified as a tag channel.

✓ Clearing all tag channels:

While pushing [HI/LO], push and hold [SCAN•TAG] for 3 sec. until the long beep becomes 2 short beeps.

- All tag channels in the selected channel group are released.

◇ Scan operation

- ① Select the desired channel group (USA, CAN, INT) or WX channels with [CH/WX•U/I/C].
 - When the weather alert function is in use, select the desired WX channel in the display, then perform the above operation.
- ② Push [SCAN] to start scanning.
 - “SCAN” appears and flashes in the function display.
 - “16” appears during priority scan.
- ③ To stop the scan, push [SCAN] again.
 - “SCAN” disappears.

✓ Scan resume timer:

When a signal is detected, scan pauses until the signal disappears or resumes after pausing 5 sec., according to the set mode setting. (p. 19)

✓ Confirming tag channels:

While operating scan, rotate [DIAL].

- Only tag channels are selected.
- Stop rotating [DIAL] to resume scan.

✓ Weather alert function:

When the function is turned ON (p. 19), the selected weather channel is checked during scan. Refer to p. 7 for a description of weather alert.

■ Call channel programming

The call channel key, [9], is used to select channel 9, however, you can program your most often-used channels in each channel group for quick recall.

- ① Push [CH/WX•U/I/C] for 1 sec. one or more times to select the desired channel group (USA, INT, CAN) to be programmed.

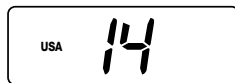

- ② Push [9] to select the call channel of the selected channel group.



- "CALL" and the call channel number appear.

- ③ While pushing [HI/LO] push [9] to enter call channel write mode.



- Call channel number and channel group to be programmed flash.

- ④ Rotate the channel selector to select the desired channel.



- ⑤ Push [9] again to program the displayed channel as the call channel.



- The call channel number and channel group stop flashing.

■ Display backlighting

The function display and switches can be backlit for better visibility under low light conditions.

While pushing [HI/LO•DIM], rotate the channel selector to adjust the backlighting.

- ➔ Backlighting can be set to 1 of 3 intensities or turned OFF.

■ General

When an optional UX-120 DSC UNIT is installed, digital selective calling (or DSC) can be used via the IC-M59. DSC is a method of radio communications involving digital signals rather than the more conventional method of voice communications. The advantage of using digital communications over voice communications is that information (especially useful for distress calls and other urgent matters) can be pre-programmed into a radio and transmitted accurately.

In addition, when a GPS receiver (NMEA0183 ver. 1.5, 2.0 or 2.1) is connected, your vessel's position and the current UTC time are transmitted together with the vessel's identity when making a distress call.

See p. 27 for unit installation.

DSC TYPE	DESCRIPTION	REF.
Distress call	This sends distress information which includes your vessel's ID (and position data/UTC time when a GPS receiver is connected). Send under <i>emergency conditions only</i> . DSC acknowledgement will be received from a coast station after making a distress call.	pgs. 13, 16
Distress relay call	This is used to alert Coast stations (or other ships) when a vessel in distress is unable to do so. The IC-M59 can <i>only receive</i> this type of signal; not transmit.	p. 16
All ships call	This is used for non-emergency situations. This signal includes information which allows a receiving transceiver to automatically select a specified channel for voice communication.	pgs. 14, 16
Individual call	This allows you to send a signal to a specific vessel only. The vessel's ID code must be pre-programmed in advance. Two kinds of acknowledgements (able to comply/unable to comply) are available (for sending or receiving) after an individual call.	pgs. 15, 17
Geographical area call	This is used for announcement to all ships in the specified area—when a GPS receiver is connected calls directed to areas other than yours are rejected. <i>Receive only</i> for the IC-M59.	p. 17

■ Distress call transmission

CAUTION: Distress calls may be transmitted under conditions of emergency only i.e. your vessel is in danger of sinking and/or a person's life is in danger.

- ① Push and hold [16•EMER] until you hear 4 short beeps change to one long beep.
 - The display changes as at right.
- ② Push [PTT] to transmit the distress call.



- ③ The transceiver remains on channel 70 until an acknowledgement is received.
 - When no acknowledgement is received, the distress call is repeated until an acknowledgement is received.
 - To cancel this, turn power OFF then ON again.
 - Calls to you other than distress acknowledgement cannot be received.

- ④ When a distress acknowledgement is received, emergency alarm sounds and channel 16 is automatically selected.
 - Push any key to cancel the alarm.



- ⑤ Transmit your distress call particulars by voice using the following procedure:

1. "MAYDAY."
2. "THIS IS " (name of vessel).
3. The 9-digit identity AND the call sign (or other identification of the vessel).
4. The vessel's position if DSC does not include it.
5. The nature of the distress and assistance required.
6. Any other information which might facilitate the rescue.

NOTE: When a GPS receiver (NMEA 0183) is connected, your vessel's position is automatically transmitted with the distress call.

NOTE: Acknowledgement of a DSC distress alert is normally made by coast stations only.

4 DIGITAL SELECTIVE CALLING

■ All ships call transmission

Large ships use channel 70 as their “listening channel.” When you want to announce a message to these ships, use the “all ships call” function.

- ① Select a simplex channel for the traffic channel (for voice communication after sending the all ships call).

- Some ‘A’ channels (eg. channel 88A) cannot be used.



- ② Rotate [SQUELCH] clockwise until the audio noise disappears.

- ③ While pushing [9•ALL/IND] rotate the channel selector to select “ALL” as at right.



- ④ Push and hold [9•ALL/IND] until you hear 4 short beeps change to one long beep.

- The display changes as at right.



- ⑤ Push [PTT] momentarily to transmit the all ships call.

- After transmission, the channel set in step ① above is selected.



- ⑥ Push and hold [PTT] again to send an announcement to all ships.

NOTE: *Channel busy*

When channel 70 is busy, the all ships call is not transmitted. The transceiver waits until the channel is clear, then transmits the call automatically.



This display appears while the call is in standby.

NOTE: *Error indication*

When a transmission inhibited channel (e.g. ch 70) is selected for the traffic channel, the display at right appears. In this case, an appropriate channel must be selected.

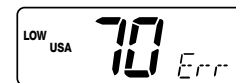

This display may also appear if [9•ALL/IND] is accidentally released early while being pushed and held in step ③.

Individual call transmission

The individual call function allows you to transmit a DSC signal to a specific party only.

- ① Set the ID code for the individual you wish to call in advance.
 - This code is input into the address item in SET mode. (p. 19)
- ② Select the traffic channel (for voice communication after the individual call is sent).
 - Select a simplex channel (some 'A' channels cannot be used) for ship-to-ship contact.
 - Select a duplex channel for ship-to-coast contact.
- ③ Rotate [SQUELCH] clockwise until the audio noise disappears.
- ④ While pushing [9•ALL/IND] rotate the channel selector to select "Ind" as at right.
 - When no address ID is pre-programmed, "Ind" cannot be selected.
- ⑤ Push and hold [9•ALL/IND] until you hear 4 short beeps change to one long beep.
 - The display changes as at right.
 - When "ALL" appears instead of "Ind," rotate the channel selector to select "Ind" while pushing [9•ALL/IND].
- ⑥ Push [PTT] momentarily to transmit the individual call.
 - "HIGH" power is automatically selected while transmitting the call.



- ⑦ Standby on channel 70 until an acknowledgement is received.
- ⑧ When the acknowledgement is received, the display changes as at right.
 - Beeps sound.
 - The channel set in step ② is selected.
- ⑨ Push and hold [PTT] to communicate your message to the responding party.

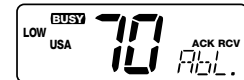

- NOTE: Unable to comply**
When the received acknowledgement includes "unable to comply," the message display changes as at right. In such a case, wait at least 5 min. before re-transmitting the call.



- NOTE: Channel busy error indication**
The same as for the all ships call. Refer to the page opposite for details.

4 DIGITAL SELECTIVE CALLING

■ Receiving DSC calls

Several types of DSC transmissions can be received. The required action depends on the particular DSC type as outlined in the following examples. However, in all examples, you must be monitoring channel 70 in order to receive such signals.

NOTE: When channel 70 is set as a tag channel and scan is functioning, DSC calls will not be received. DSC calls can only be received when channel 70 is selected.

◇ Receiving a distress call

While monitoring channel 70 and a distress call is received:

- ➔ Emergency alarm sounds.
- ➔ “RCV” and “dTR” appear in the display; then, channel 16 is automatically selected.
- ➔ Push [16] to stop the alarm.
- ➔ Continue monitoring channel 16 as a coast station may require assistance in any rescue attempt.

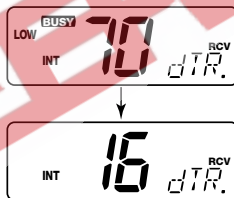

◇ Receiving a distress relay call

A distress relay call may be transmitted from a large ship to a coast station. While monitoring channel 70 and a distress relay call is received:

- ➔ Emergency alarm sounds.
- ➔ “RCV” and “RLY” appear in the display; then, channel 16 is automatically selected.
- ➔ Push [16] to stop the alarm.
- ➔ Monitor channel 16 until the emergency communication has been completed.

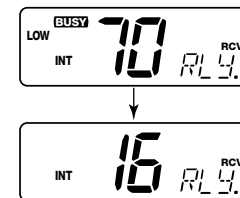

◇ Receiving an all ships call

While monitoring channel 70 and an all ships call is received:

- ➔ Emergency alarm or beeps sound depending on the received category.
- ➔ “RCV” and “ALL” appear in the display; then, the channel specified by the calling station is automatically selected for voice communications.
- ➔ Monitor the selected channel for an announcement from the calling vessel.

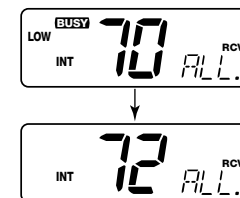

◇ Receiving a geographical area call

While monitoring channel 70 and a geographical area call (for the area you are in) is received:

- Emergency alarm or beeps sound depending on the received category.
- “RCV” and “GEO” appear in the display; then, the channel specified by the calling station is automatically selected for voice communications.
- Monitor the selected channel for an announcement from the calling ship.

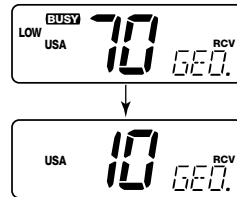

/// **NOTE:** When no GPS receiver is connected or if there is a problem with the connected receiver, all geographical area calls are received, regardless of your position.

◇ Receiving an individual call

When receiving an individual call, an acknowledgement must be sent back to the calling station within 4.5 min. Operation and transceiver function differs depending on the SET mode settings.

Two messages can be selected for acknowledgement:

- “Able to comply”You can communicate with the calling vessel via the mic after a DSC connection.
- “Unable to comply”You cannot communicate with the calling vessel after a DSC connection (e.g. operator leaves transceiver).

While monitoring channel 70 and an individual call is received:

- Emergency alarm or beeps sound depending on the received category.
- “RCV” and “Ind” appear in the display.
- The channel specified by the calling station is automatically selected for checking the channel condition (except when full automatic acknowledgement is selected).
- Proceed as follows on the next page according to your preset conditions.

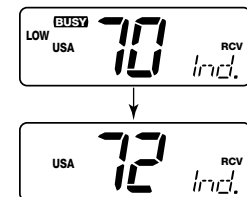

4 DIGITAL SELECTIVE CALLING

- When semi-automatic (SA; default) or manual (SL) is selected in SET mode (p. 21):

① Push and hold [9•ALL/IND] until you hear 4 short beeps change into one long beep to send “Able to comply” message.

- If you want to send “Unable to comply” message, or other individual or all ships call, rotate the channel selector to select them.

② Push [PTT] momentarily to transmit the acknowledgement.

- The channel specified by the calling station is selected.
- When “Unable to comply” is transmitted in step ①, the transceiver remains on channel 70.

③ After receiving a voice transmission, reply via the mic.



- When full automatic (FA) is selected in SET mode (p. 21):

➔ The transceiver automatically replies to the call in one of two ways, depending on the auto acknowledge setting in SET mode (p. 21).

- When able to comply is set (Ab), the transceiver automatically transmits an able to comply acknowledgement and then selects the channel as specified by the calling station for voice communications.



- When unable to comply is set (Un), the transceiver automatically transmits an unable to comply acknowledgement and remains on channel 70.



⚡ Differences between semi-automatic and manual

Semi-automatic: When no operation is performed, the transceiver automatically sends an “Unable to comply” acknowledgement 4.5 min. after the call is received.

Manual: When no operation is performed after receiving a call, NO acknowledgement is transmitted.

■ Entering SET mode

SET mode is used to customize operation of the transceiver to suit your operating needs.

◇ To enter SET mode:

- ① While pushing [16], turn power ON.
 - Keep pushing [16] until the initial SET mode display appears.
 - SET mode is selected.
- ② To exit SET mode, turn power OFF then ON again.

◇ To select an item:

There are up to 8 items in SET mode (depending on options installed) that may be adjusted to suit your operating needs.

- ① Select SET mode as above.
- ② Push [16] to select the desired item; then rotate [CHANNEL] to select the desired condition.
 - See the following pages for details on each SET mode item.

 The diagram at right shows the default settings for each SET mode item and the order of selection.

 Items inside dotted lines only appear when optional units are installed.

■ SET mode items

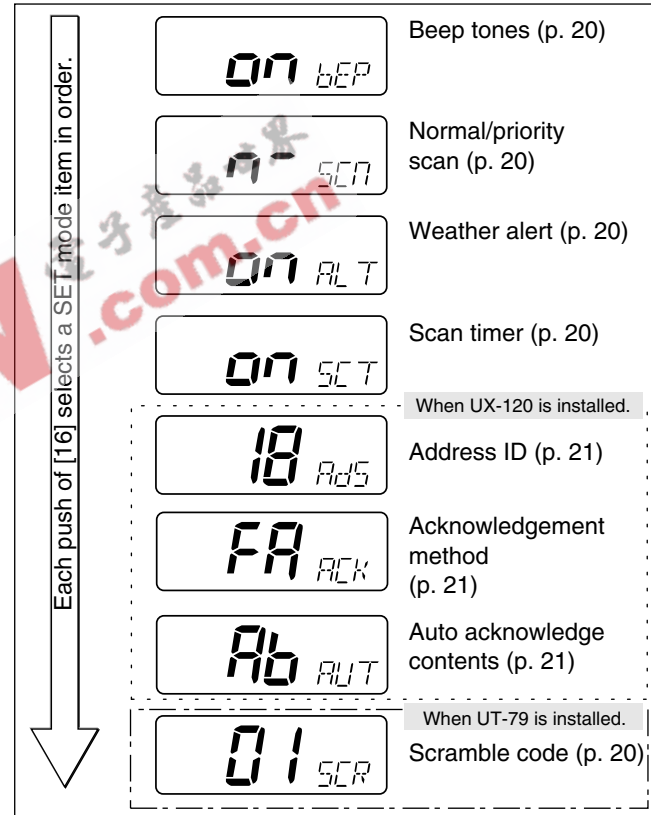

5 SET MODE

◇ BEEP TONES

This item sets the transceiver's confirmation beep tones (when pushing a switch/rotating [CHANNEL]) ON or OFF.

Beep tones ON (default)



Beep tones OFF

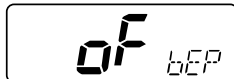

/// **NOTE:** Emergency alarm and beeps for DSC operation cannot be turned OFF.

◇ SCAN TIMER

This item sets the scan timer ON or OFF.

Scan timer ON (default)



Scan timer OFF



- Scan pauses on a signal and resumes 5 sec. later.

- Scan pauses on a signal until the signal disappears, and resumes 2 sec. after that.

◇ NORMAL/PRIORITY SCAN

This item sets the scan function to normal or priority operation. (See p. 10)

Normal scan (default)

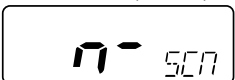

Priority scan



◇ SCRAMBLE CODE

This item sets a scramble code for communication using the optional voice scrambler unit. (p. 8)

Scramble code "01"



Scramble code "127"

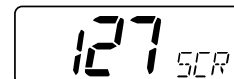

◇ WEATHER ALERT

This item sets the weather alert function ON or OFF. (p. 7)

Weather alert ON (default)



Weather alert OFF



◇ ADDRESS

This item sets the other station's 10-digit ID code for individual calls. Note that your own ID cannot be set in SET mode.

- ① Push [9] to select the digit (1 through 10).
- ② Rotate [CHANNEL] to set the desired value for the selected digit or turn the individual call OFF.
 - Select “-” to clear the digit and turn the individual call OFF.

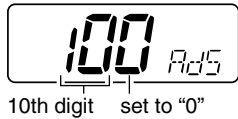

NOTE: The 10th digit must be set to “0” when your ID is 9 digits. This is reserved for future use.

[EXAMPLE]: Setting the ID code to 6042737400

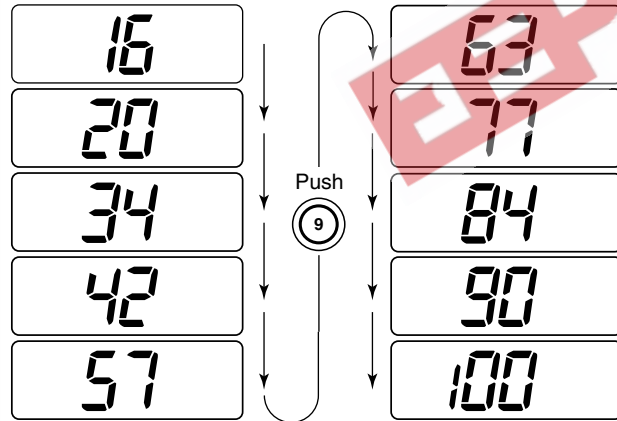

◇ ACKNOWLEDGEMENT METHOD

This item sets the acknowledgement method for reply to a calling station when receiving an individual call. (See p. 18)

Full automatic



Acknowledgement is transmitted automatically using the specified message.

Semi automatic



Acknowledgement is transmitted manually. If no transmission for 4.5 min., acknowledgement is transmitted automatically using the “Unable to comply” message.

Manual



Acknowledgement can only be transmitted manually.

◇ AUTO ACKNOWLEDGE CONTENTS

Appears only when full automatic (FA) is selected in the previous item. This item sets “unable to comply” or “able to comply”

Able to comply



Unable to comply



as the full automatic acknowledgement transmission. (p. 18)

■ Unpacking

① Mounting bracket	1
② DC power cable (OPC-632)	1
③ Microphone hanger (OPC-562)	1
④ Mounting bracket knobs	4
⑤ Mounting screws (5 x 20)	4
⑥ Mic hanger screws (3.5 x 30)	2
⑦ Flat washers (M4)	2
⑧ Sticker (for scrambler function)*	1

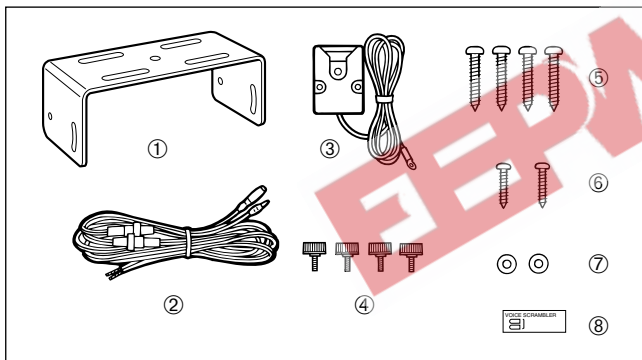

* Attach the sticker on the top side of the front panel when the UT-79 is installed.

■ Additional requirements

◇ FOR GENERAL OPERATION

- Marine VHF antenna
- Coaxial cable

◇ FOR DSC OPERATION

- UX-120 DSC UNIT

◇ FOR ENHANCED DSC OPERATION

- GPS receiver with NMEA0183 output for sending positioning and time data with a distress call

◇ FOR VOICE SCRAMBLER OPERATION

- UT-79 VOICE SCRAMBLER UNIT

Consult with your dealer if you need this function—disassembly and soldering of the transceiver are required for installation.

■ Connections

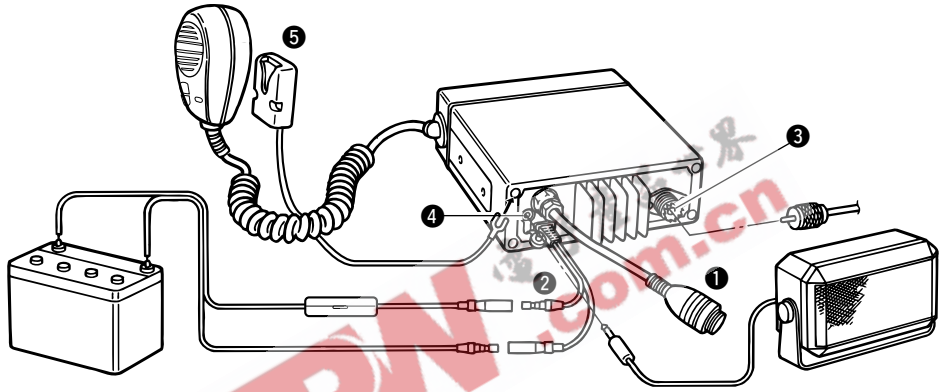

1 DSC CONNECTOR (optional OPC-457; through the UX-120)
 7-pin plug connects a GPS receiver for transmission of position data and time.

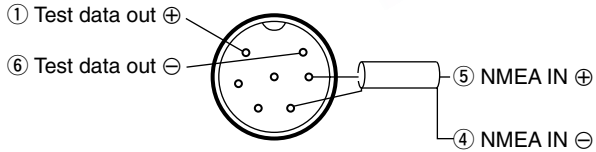

Acceptable command: GAA
 Acceptable format: NMEA0183 ver. 1.5, 2.0 or 2.1

2 DC POWER CONNECTOR
 Connects the supplied DC power cable from this connector to an external 12 V DC power source.

3 ANTENNA CONNECTOR
 Connects a marine VHF antenna with a PL-259 connector to the transceiver.

CAUTION: Transmitting without an antenna will damage the transceiver.

4 EXTERNAL SPEAKER JACK

5 MICROPHONE HANGER

Connects to the transceiver's ground. Resting the microphone on the hanger automatically selects channel 16.

6 CONNECTIONS AND MAINTENANCE

■ Mounting the transceiver

The universal mounting bracket supplied with your transceiver allows overhead or dashboard mounting. Please read the following instructions carefully.

- Mount the transceiver securely with the 4 supplied screws (M5 x 20) to a surface which is more than 10 mm thick and can support more than 5 kg.
- Mount the transceiver so that the face of the transceiver is at 90 ° to your line of sight when operating it.

CAUTION: KEEP the transceiver and microphone at least 1 meter away from your vessel's magnetic navigation compass.

NOTE: Check the installation angle; the function display may not be easy-to-read at some angles.

NOTES FOR SUPPLIED STICKER

When installing an optional UT-79 VOICE SCRAMBLER UNIT: Attach the operation sticker on the top side of the front panel for reference.

When installing an optional UX-120 DSC UNIT: Attach the WARNING sticker supplied with the UX-120 near the transceiver's front panel so that it is clearly visible during operation.

DASHBOARD MOUNTING (with optional MB-28)

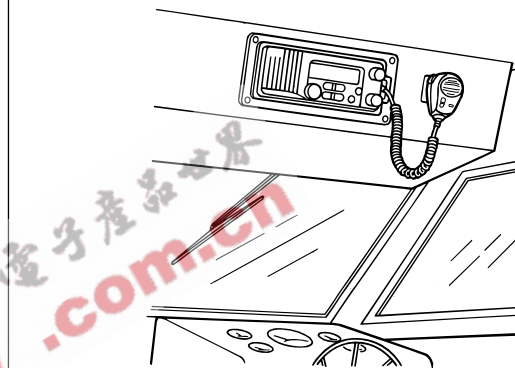

OVERHEAD MOUNTING

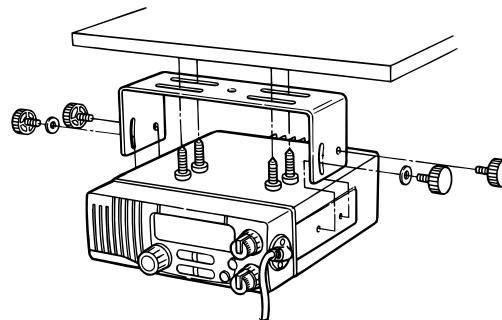

■ Dimensions

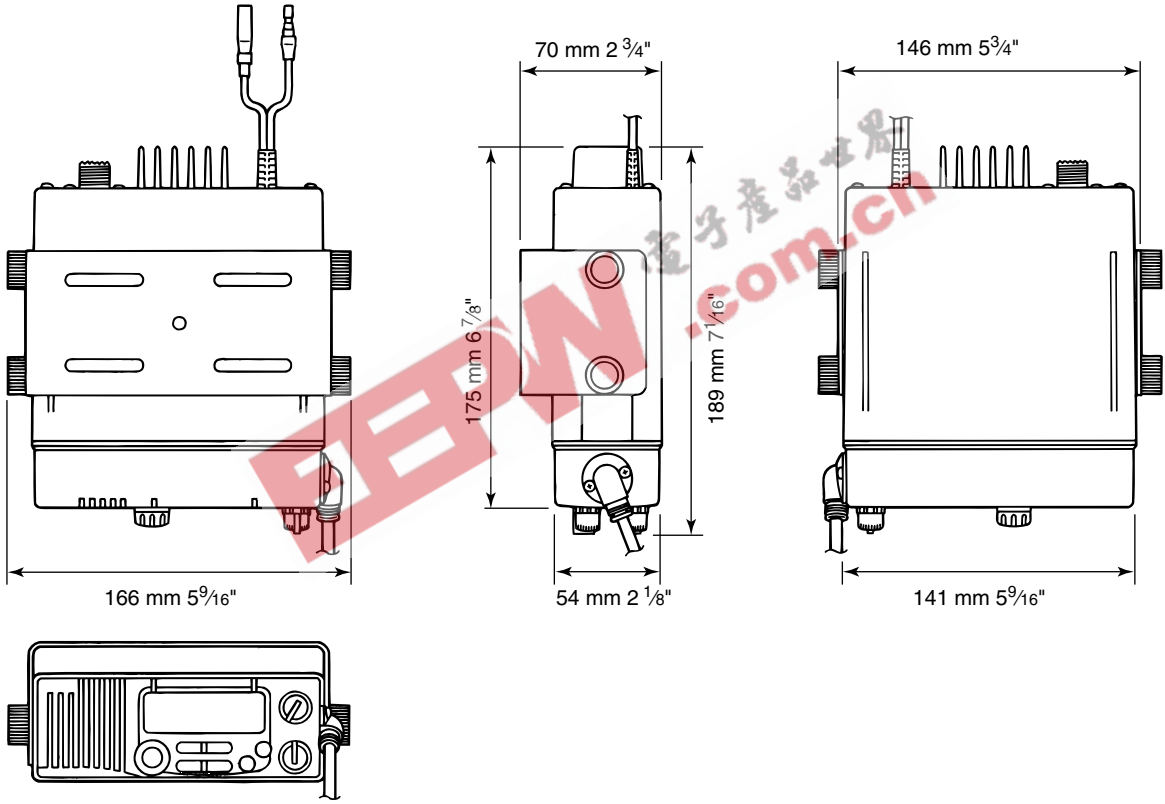

6 CONNECTIONS AND MAINTENANCE

■ Antenna

A key element in the performance of any communication system is an antenna. Ask your Dealer about antennas and the best places to mount them.

■ Fuse replacement

Two fuses are installed in the supplied DC power cable. If a fuse blows or the transceiver stops functioning, track down the source of the problem, if possible, and replace the damaged fuse with a new, rated one.

☛ Fuse rating: 10 A

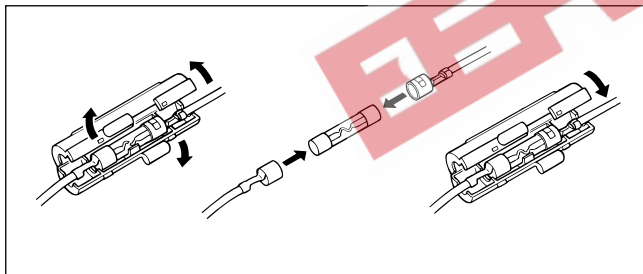

■ Cleaning

If the transceiver becomes dusty or dirty, wipe it clean with a dry, soft cloth.



AVOID the use of solvents such as benzene or alcohol, as they may damage transceiver surfaces.

■ Optional unit installations

In order to add the DSC or voice scrambler functions to the IC-M59, the following optional units must be installed.

UX-120: DSC functions

OPC-457: GPS connection when UX-120 is installed

UT-79: Voice scrambler function

- ① Turn the transceiver power OFF and disconnect the DC power cable.
- ② Unscrew 4 screws from the rear panel, then remove the transceiver cover. (fig. 1)
- ③ Install the desired unit. (fig. 2 to 4)
- ④ Replace the transceiver cover and tighten the screws.
 - 4 to 6 kg of torque **MUST** be applied to ensure water resistance.

Opening the transceiver case (Fig. 1)

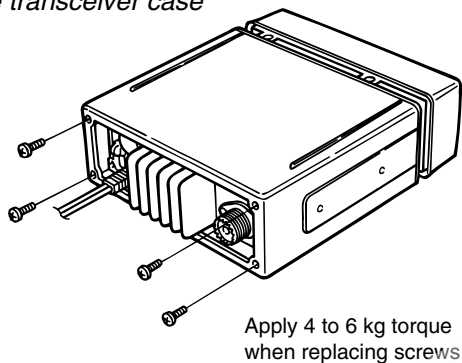

Apply 4 to 6 kg torque when replacing screws.

UT-79 installation (Fig. 2)

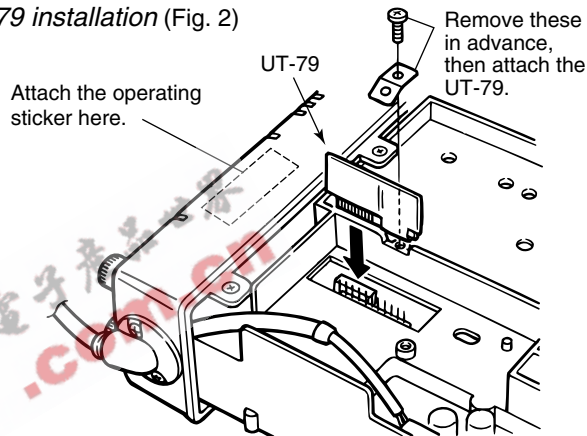

Attach the operating sticker here.

Remove these in advance, then attach the UT-79.

UX-120 installation (Fig. 3)

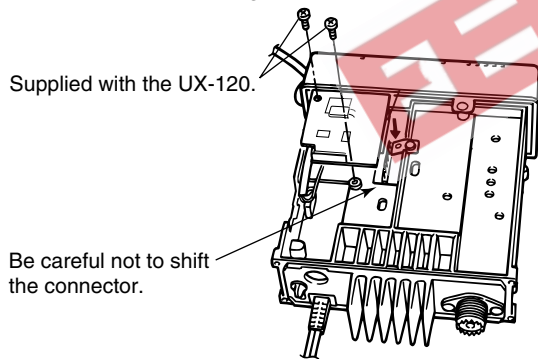

Supplied with the UX-120.

Be careful not to shift the connector.

OPC-457 installation (Fig. 4)

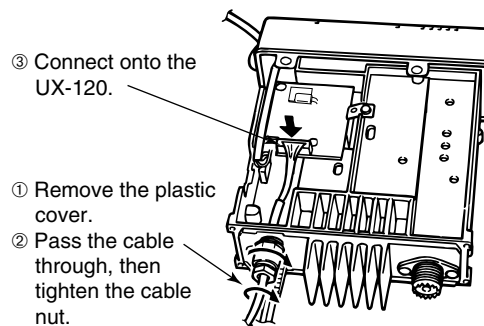

③ Connect onto the UX-120.

① Remove the plastic cover.

② Pass the cable through, then tighten the cable nut.

PROBLEM	POSSIBLE CAUSE	SOLUTION	REF.
No power comes on.	<ul style="list-style-type: none"> • Power cord not connected properly. • Blown fuse. 	<ul style="list-style-type: none"> • Check the power cord connection. • Check the polarity of the power connection, then, replace the fuse. 	p. 23 p. 26
No sound comes from the speaker.	<ul style="list-style-type: none"> • [SQUELCH] is rotated too far clockwise. 	<ul style="list-style-type: none"> • Rotate [SQUELCH] counterclockwise to a suitable position. 	p. 8
No beeps sound even when a switch is pushed.	<ul style="list-style-type: none"> • Beep function is turned OFF. 	<ul style="list-style-type: none"> • Set beeps to ON in SET mode. 	p. 20
Sensitivity is low and only strong signals are audible.	<ul style="list-style-type: none"> • [SQUELCH] is rotated too far clockwise. • Antenna feedline or the antenna connector solder has poor contact or is short circuited. 	<ul style="list-style-type: none"> • Rotate [SQUELCH] counterclockwise to a suitable position. • Check, and if necessary, replace the feedline or solder the antenna connector again. 	p. 8 p. 23
Transmitting is impossible or high power cannot be selected.	<ul style="list-style-type: none"> • Transmission is restricted on some channels. 	<ul style="list-style-type: none"> • Change channels. 	p. 29
Desired channel cannot be selected.	<ul style="list-style-type: none"> • Different channel group is selected. 	<ul style="list-style-type: none"> • Push and hold [CH/WX • U/I/C] to select the appropriate channel group (U.S.A., INT or CAN). 	p. 7
No display backlighting.	<ul style="list-style-type: none"> • Backlight function is turned OFF. 	<ul style="list-style-type: none"> • While pushing [HI/LO • DIM], rotate the channel selector to select the desired brightness. 	p. 11
Scan does not start.	<ul style="list-style-type: none"> • No "TAG" channels are programmed. 	<ul style="list-style-type: none"> • Set channels to be scanned as "TAG" channels. 	p. 10
Receive signal cannot be understood.	<ul style="list-style-type: none"> • Voice scrambler has been turned OFF. • Voice scrambler code has not been set correctly. 	<ul style="list-style-type: none"> • Install the optional UT-79, then activate the function. • Reset the scramble code. 	p. 8 p. 20

VHF MARINE CHANNEL LIST

Channel number			Frequency (MHz)	
USA	INT	CAN	Transmit	Receive
	01	01	156.050	160.650
01A			156.050	156.050
	02	02	156.100	160.700
02A			156.100	156.100
	03	03	156.150	160.750
03A			156.150	156.150
	04		156.200	160.800
04A		04A	156.200	156.200
	05		156.250	160.850
05A		05A	156.250	156.250
06	06	06	156.300	156.300
	07		156.350	160.950
07A		07A	156.350	156.350
08	08	08	156.400	156.400
09	09	09	156.450	156.450
10	10	10	156.500	156.500
11	11	11	156.550	156.550
12	12	12	156.600	156.600
13 ^{*2}	13	13 ^{*1}	156.650	156.650
14	14	14	156.700	156.700
15 ^{*2}	15 ^{*1}	15 ^{*1}	156.750	156.750
16	16	16	156.800	156.800
17 ^{*1}	17	17 ^{*1}	156.850	156.850
	18		156.900	161.500
18A		18A	156.900	156.900

Channel number			Frequency (MHz)	
USA	INT	CAN	Transmit	Receive
	19		156.950	161.550
19A		19A	156.950	156.950
20	20	20	157.000	161.600
20A			157.000	157.000
	21	21	157.050	161.650
21A		21A	157.050	157.050
	22		157.100	161.700
22A		22A	157.100	157.100
	23	23	157.150	161.750
23A			157.150	157.150
24	24	24	157.200	161.800
25	25	25	157.250	161.850
26	26	26	157.300	161.900
27	27	27	157.350	161.950
28	28	28	157.400	162.000
	60	60	156.025	160.625
60A			156.025	156.025
	61		156.075	160.675
61A		61A	156.075	156.075
	62		156.125	160.725
62A		62A	156.125	156.125
	63		156.175	160.775
63A			156.175	156.175
	64	64	156.225	160.825
64A		64A	156.225	156.225

Channel number			Frequency (MHz)	
USA	INT	CAN	Transmit	Receive
	65		156.275	160.875
65A	65A	65A	156.275	156.275
	66		156.325	160.925
66A	66A	66A ^{*1}	156.325	156.325
67 ^{*2}	67	67	156.375	156.375
68	68	68	156.425	156.425
69	69	69	156.475	156.475
70 ^{*3}	70 ^{*3}	70 ^{*3}	156.525	156.525
71	71	71	156.575	156.575
72	72	72	156.625	156.625
73	73	73	156.675	156.675
74	74	74	156.725	156.725
75	75	75	Guard	Guard
76	76	76	Guard	Guard
77 ^{*1}	77	77 ^{*1}	156.875	156.875
	78		156.925	161.525
78A		78A	156.925	156.925
	79		156.975	161.575
79A		79A	156.975	156.975
	80		157.025	161.625
80A		80A	157.025	157.025
	81		157.075	161.675
81A		81A	157.075	157.075
	82		157.125	161.725
82A		82A	157.125	157.125

Channel number			Frequency (MHz)	
USA	INT	CAN	Transmit	Receive
	83	83	157.175	161.775
83A		83A	157.175	157.175
84	84	84	157.225	161.825
84A			157.225	157.225
85	85	85	157.275	161.875
85A			157.275	157.275
86	86	86	157.325	161.925
86A			157.325	157.325
87	87	87	157.375	161.975
87A			157.375	157.375
88	88	88	157.425	162.025
88A			157.425	157.425
WX channel	Frequency (MHz)			
	Transmit	Receive		
01	RX only		162.550	
02	RX only		162.400	
03	RX only		162.475	
04	RX only		162.425	
05	RX only		162.450	
06	RX only		162.500	
07	RX only		162.525	
08	RX only		161.650	
09	RX only		161.775	
10	RX only		163.275	

*1 Low power only. *2 Momentary high power. *3 Receive only (except for DSC transmissions).

General

- Frequency coverage : Transmit 156–157.5 MHz
Receive 156–163 MHz
- Usable channels : All U.S.A., International and Canadian channels plus 10 weather channels
- Mode : 16K0G3E, (16K0G2B when optional DSC is in use)
- Power supply requirement : 13.8 V DC \pm 15%
- Current drain : Transmit
(at 13.8 V DC) high power 6.0 A
low power 1.5 A
Receive
standby 350 mA
max. audio output 1.2 A
- Frequency stability : \pm 10 ppm
- Usable temp. range : -20°C to $+60^{\circ}\text{C}$;
 -4°F to $+140^{\circ}\text{F}$
- Dimensions : 140(W) x 55(H) x 155(D) mm
(projections not included) $5\frac{1}{2}$ (W) x $2\frac{5}{32}$ (H) x $6\frac{3}{32}$ (D) in
- Weight : 1.0 kg; 2.2 lb

Transmitter

- Output power : High 25 W Low 1 W
- Modulation system : Variable reactance phase modulation
- Max. frequency deviation : \pm 5.0 kHz
- Spurious emissions : Less than -70 dB
- Microphone impedance : 600 Ω

Receiver

- Receive system : Double conversion superheterodyne
- Intermediate frequencies : 1st 21.8 MHz 2nd 455 kHz
- Sensitivity : 0.22 μV (typical) for 12 dB SINAD
- Squelch sensitivity : 0.18 μV at threshold
- Adjacent channel selectivity : More than 70 dB
- Spurious response rejection : More than 70 dB
- Intermodulation rejection : More than 70 dB
- Audio output power : 3.5 W at 10% distortion
- Audio output impedance : 4 Ω

All stated specifications are subject to change without notice or obligation

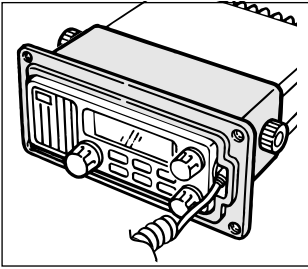

MB-28 FLUSH MOUNT

For mounting the IC-M59 to a panel. Available in black or white.

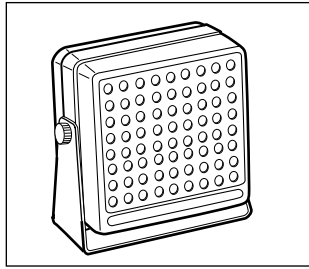

SP-5 EXTERNAL SPEAKER

A large, external speaker for superior audio output.

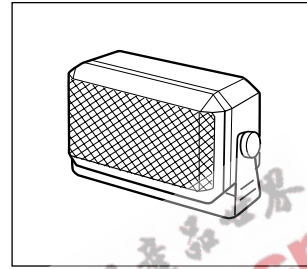

SP-10 EXTERNAL SPEAKER

A compact, external speaker. Features easy installation.

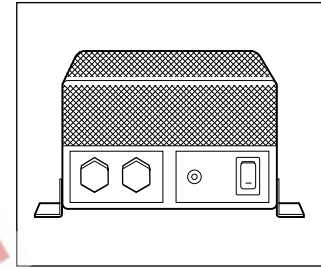

PS-66 DC-DC CONVERTER

Input voltage: 19 to 32 V DC
Output voltage: 13.6 V DC

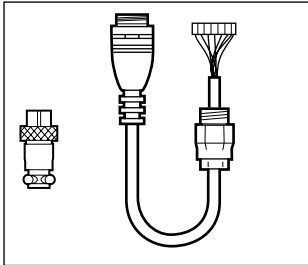

OPC-457

NMEA CABLE

Allows you to connect NMEA equipment such as a GPS receiver.

◆ INTERNAL UNITS

• UT-79 VOICE SCRAMBLER UNIT

Provides private communications. Analog-type voice scrambling unit with 128 scramble codes available.

• UX-120 DSC UNIT

When the UX-120 is installed, the transceiver conforms to U.S. Coast Guard proposal SC-101 for marine digital communications.

Count on us!

EPW 電子產品世界 .com.cn

A-5384D-1EX-①
Printed in Japan
Copyright © 1996 by Icom Inc.

Icom Inc.
1-1-32 Kamiminami, Hirano-ku, Osaka 547-0003 Japan