

Vertical Cavity Surface Emitting Laser in ST Optical Sub-Assembly



OPV214AT, OPV214BT, OPV214YAT, OPV214YBT

Technical Data

Features

- 850 nm VCSEL technology
- High thermal stability
- Up to 1.25 Gbps
- Recommended for multimode fiber applications
- Microbead lens
- Pin out and attenuation options available on request
- Burned in for communication level reliability
- High optical coupling to MM fiber
- ST* style receptacle

Description

The OPV214AT and OPV214BT are high performance 850nm VCSEL packaged for high speed communication links. OPV214AT and OPV214BT combines all the performance advantages of a VCSEL with the addition of a power monitor diode for precise control of optical power.

The OPV214YAT and OPV214YBT are identical electrically and optically and differ only in pin out. Refer to mechanical drawings for details.

This product's combination of features including high speed, high output power and concentric beam make it an ideal transmitter for integration into all types of data communications equipment.

Applications include:

- ◆ Fibre Channel
- ◆ Gigabit Ethernet
- ◆ ATM
- ◆ VSR (Very Short Reach)
- ◆ Intra-system links
- ◆ Optical backplane interconnects.



Absolute Maximum Ratings ($T_A = 25^\circ\text{C}$ unless otherwise noted)

Storage Temperature	-40° C to +125° C
Operating Temperature	-40° C to +85° C
Soldering Lead Temperature	260° C for 10 Seconds
Maximum Forward Peak Current	30 mA
Maximum Reverse Voltage	5 V



This product is classified as 1M per EN/IEC60825-1/A2:2001. The output from class 1M products must not be viewed directly using optical magnifiers within a distance of 100mm (4 inches). Additional laser safety information can be found on the Optek website. See application bulletin #221.

* - ST is a registered trademark of AT&T

OPV214AT, OPV214BT, OPV214YAT, OPV214YBT Technical Data



Electrical/Optical Characteristics (at 25 °C unless otherwise specified)

SYMBOL	PARAMETER	MIN	TYP	MAX	UNITS	TEST CONDITION
P _{T50}	Total Coupled Power 50/125 μm Fiber	800			μW	I _F = 12 mA
		400			μW	I _F = 12 mA
I _{TH}	Threshold Current	2.0		5.5	mA	Note 1
V _F	Forward Voltage	1.7		2.15	V	I _F = 12 mA
I _R	Reverse Current			30	nA	V _R = 5 V
R _S	Series Resistance	14		40	ohms	Note 2
η	Slope Efficiency	80			μW/mA	Note 3
		40			μW/mA	Note 3
I _{RPD}	Reverse Current, photo diode			30	nA	V _R = 5 V
I _M	Monitor Current	30			μA	I _F = 12 mA, V _R = 5 V
λ	Wavelength	830		860	nm	
Δλ	Optical Bandwidth			0.85	nm	
t _r , t _f	Rise and Fall Time		200		ps	20% to 80%
N _{RI}	Relative Intensity Noise		-123		db/Hz	
Δη/ΔT	Temp Coefficient of Slope Efficiency		-0.4		%/°C	(0° - 70° C)
ΔI _{TH} /ΔT	Temp Coefficient of Threshold Current		±1.5		mA	0° - 70° C
Δλ/ΔT	Temp Coefficient of Wavelength		0.06		nm/°C	0° - 70° C
ΔV _f /ΔT	Temperature Coefficient for VF		-2.5		mV/°C	

NOTES:

- Threshold Current is based on the two line intersection method specified in Telcordia GR-468-Core. Line 1 from 6 mA to 8 mA. Line 2 from 0 mA to 2 mA.
- Series Resistance is the slope of the Voltage-Current line from 8 to 12mA.
- Slope efficiency, is the slope of the best fit LI line from 8 mA to 12mA using no larger than .5 mA test interval points. Measured with a 50/125 μm fiber.

OPV214AT, OPV214BT, OPV214YAT, OPV214YBT Technical Data



Coupled Power vs. Forward Current

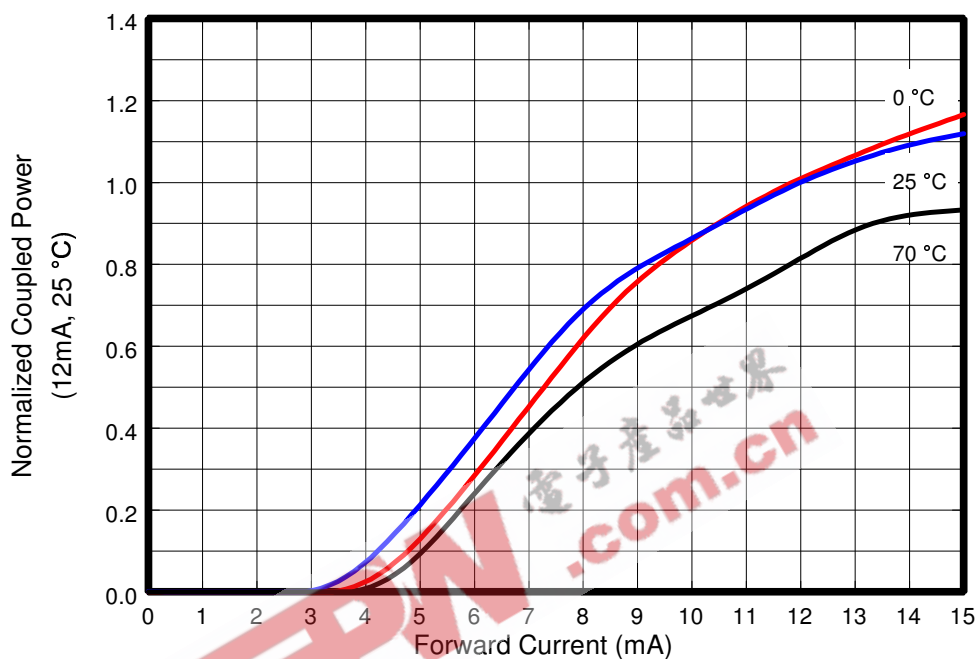

Forward Voltage vs. Forward Current

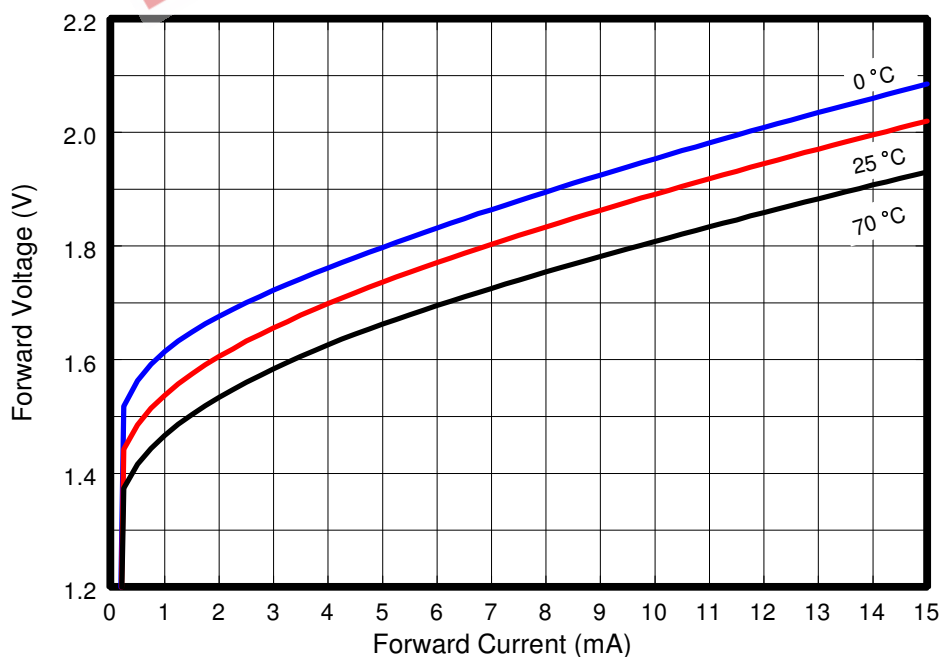

OPV214AT, OPV214BT, OPV214YAT, OPV214YBT Technical Data

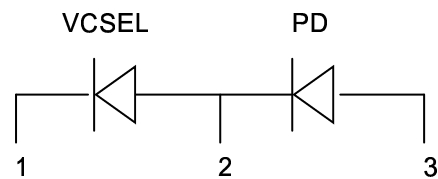
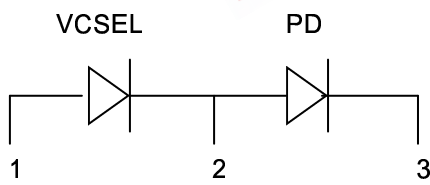
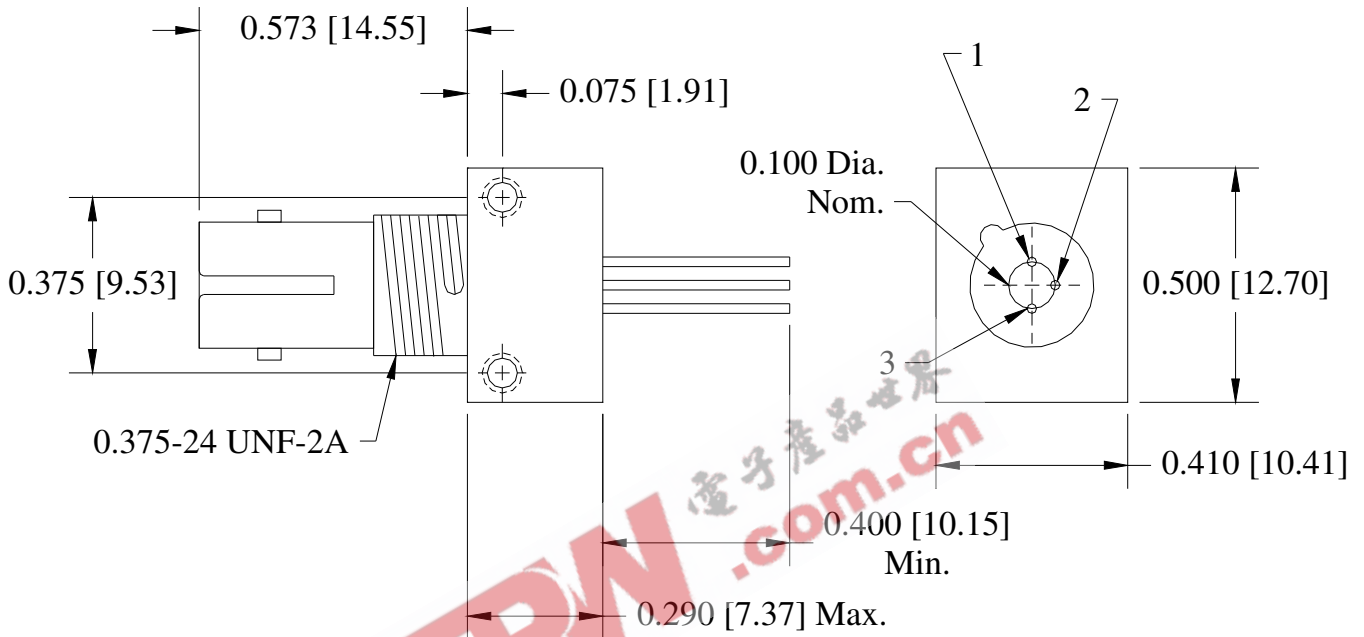

OPV214AT, OPV214BT	
Pin	Connection
1	VCSEL Anode
2	VCSEL Cathode/PD Anode
3	PD Cathode

OPV214YAT, OPV214YBT	
Pin	Connection
1	VCSEL Cathode
2	VCSEL Anode/PD Cathode
3	PD Anode