

# Reflective Object Sensor Type OPB755N

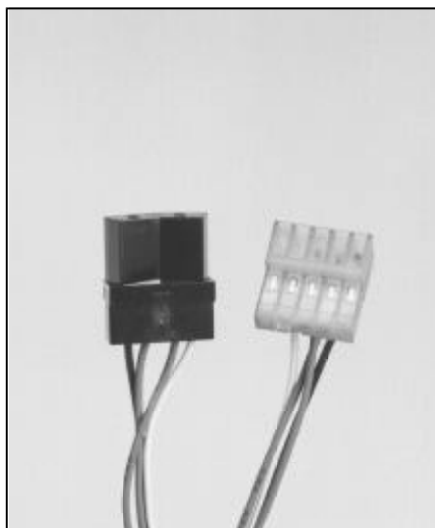

## Features

- High contrast ratio 1000 to 1 minimum
- 12.0" ± 0.5" min. UL#1429 26 AWG wire leads terminated into an AMP #640442-5 connector
- Low cost plastic housing

## Description

The OPB755N reflective assembly features a phototransistor output designed to decrease low-level light gain while not affecting the high-level light gain. Available with two mounting tabs as OPB755T.

Available with PC Board mountable leads as OPB750 series. Photologic® output sensors available in OPB760/OPB770 series.

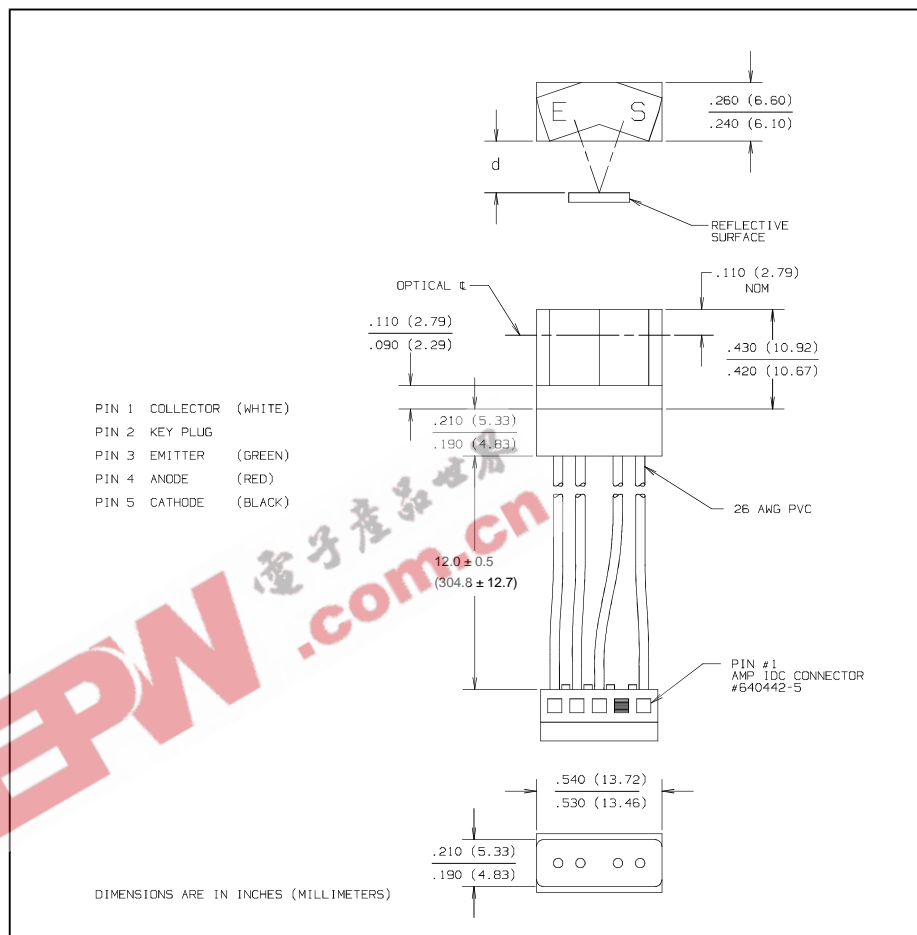

## Absolute Maximum Ratings ( $T_A = 25^\circ\text{C}$ unless otherwise noted)

Storage and Operating Temperature Range . . . . .  $-40^\circ\text{C}$  to  $+80^\circ\text{C}$

### Input Diode

Forward DC Current . . . . . 50 mA  
Peak Forward Current (1  $\mu\text{s}$  pulse width, 300 pps) . . . . . 3.0 A  
Reverse DC Voltage . . . . . 2.0 V  
Power Dissipation . . . . . 100 mW

### Output Phototransistor

Collector-Emitter Voltage . . . . . 30 V  
Collector DC Current . . . . . 30 mA  
Power Dissipation . . . . . 100 mW

### Notes:

- (1) Derate Linearly 1.82 mW/ $^\circ\text{C}$  above  $25^\circ\text{C}$ .
- (2) All parameters tested using pulse technique.
- (3) Methanol or isopropanol are recommended as cleaning agents. Plastic housing is soluble in chlorinated hydrocarbons and ketones.
- (4) Photocurrent is measured using an Eastman Kodak Neutral White test card having a 90% diffuse reflectance as a reflecting surface. Reference: Eastman Kodak, Catalog #1257795.
- (5)  $I_{C(OFF)}$  is the photocurrent measured with current to the input diode and a 5% reflecting surface.

# Type OPB755N

Electrical Characteristics ( $T_A = 25^\circ\text{C}$  unless otherwise noted)

SYMBOL	PARAMETER	MIN	MAX	UNITS	TEST CONDITIONS
<b>Input Diode</b>					
$V_F$	Forward Voltage		1.80	V	$I_F = 40\text{ mA}$
$I_R$	Reverse Current		100	$\mu\text{A}$	$V_R = 2.0\text{ V}$
<b>Output Phototransistor</b>					
$V_{(BR)CEO}$	Collector-Emitter Breakdown Voltage	30		V	$I_C = 100\ \mu\text{A}$
$I_{CEO}$	Collector Dark Current		100	nA	$V_{CE} = 10\text{ V}, I_F = 0, H = 0$
<b>Coupled</b>					
$V_{CE(SAT)}$	Saturation Voltage		0.40	V	$I_C = 150\ \mu\text{A}, I_F = 30\text{ mA}, d = 0.22''$
$I_{C(ON)}$	On-State Collector Current	500		$\mu\text{A}$	$V_{CE} = 5\text{ V}, I_F = 30\text{ mA}, d = 0.08''^{(4)}$
		375		$\mu\text{A}$	$V_{CE} = 5\text{ V}, I_F = 30\text{ mA}, d = 0.15''^{(4)}$
		250		$\mu\text{A}$	$V_{CE} = 5\text{ V}, I_F = 30\text{ mA}, d = 0.22''^{(4)}$
$I_{C(OFF)}$	Off-State Collector Current		250	nA	$I_F = 30\text{ mA}, V_{CE} = 5\text{ V},^{(5)}$ $d = 0.08'', 0.15'', 0.22''$

## Typical Performance Curves

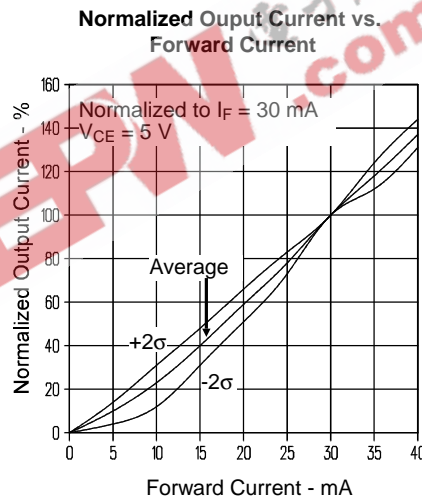
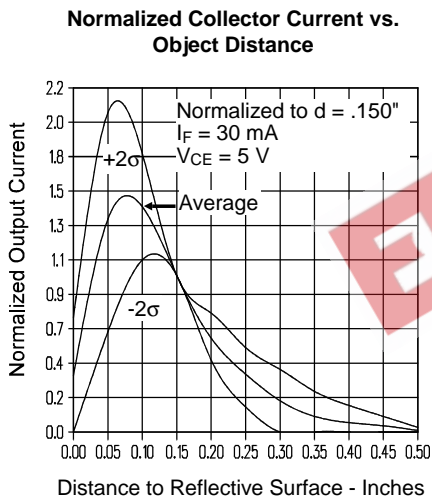

Optek reserves the right to make changes at any time in order to improve design and to supply the best product possible.

Optek Technology, Inc. 1215 W. Crosby Road Carrollton, Texas 75006 (972) 323-2200 Fax (972) 323-2396