

Reflective Object Sensor Type OPB125A

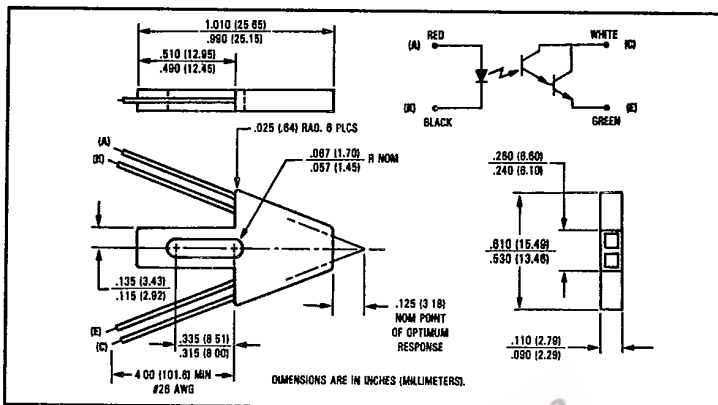
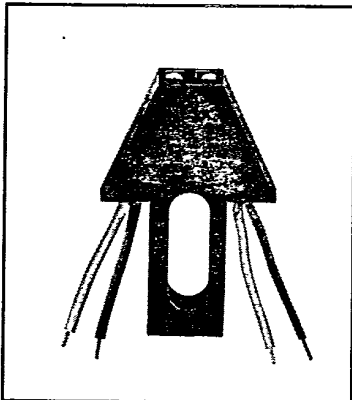

Features

- Photodarlington output
- Low profile to facilitate stacking
- Low cost plastic housing
- 4.0 inches (101.6 mm) minimum length lead wire

Description

The OPB125A consists of an infrared emitting diode and an NPN silicon photodarlington mounted side-by-side on converging optical axes, in a black plastic housing. The photodarlington responds to radiation from the LED only when a reflective object passes within its field of view.

OPB125A utilizes an OP123 or OP223 LED and an OP300 family sensor. Leads are #26 AWG, teflon insulation, 4.0" (101.6 mm) minimum length, stripped and tinned.

Absolute Maximum Ratings (T_A = 25°C unless otherwise noted)

Storage Temperature Range -40°C to +125°C
Operating Temperature Range -40°C to +100°C

Input Diode

Forward DC Current 60 mA
Reverse DC Voltage 2.0 V
Power Dissipation 80 mW⁽¹⁾

Output Photodarlington

Collector-Emitter Voltage 25 V
Emitter-Collector Voltage 5.0 V
Power Dissipation 50 mW⁽²⁾

Notes:

- (1) Derate linearly 1.07 mW/°C above 25°C.
- (2) Derate linearly 0.67 mW/°C above 25°C.
- (3) Measured using an Eastman Kodak neutral white test card having 90% diffuse reflectance as a reflecting surface.
- (4) Measured using a reflecting surface that has a very black dull surface with optical reflectance qualities comparable to a surface coated with carbon black printer's ink.
- (5) Crosstalk (I_{CE}) is the collector current measured with the indicated current in the input diode and with no reflecting surface.
- (6) Lower curve is based on a calculated worst case condition rather than the conventional -2σ limit.
- (7) d is the distance from the assembly head to the reflective surface.

T-41-73

Type OPB125A

Electrical Characteristics (T_A = 25°C unless otherwise noted)

Symbol	Parameter	Min.	Max.	Units	Test Conditions
Input Diode					
V _F	Forward Voltage		1.70	V	I _F = 50 mA
I _R	Reverse Current		100	μA	V _R = 2.0 V
Output Photodarlington					
V _{BRICEO}	Collector-Emitter Breakdown Voltage	25		V	I _C = 100 μA
V _{BRIECO}	Emitter-Collector Breakdown Voltage	5.0		V	I _E = 100 μA
I _{CEO}	Collector Dark Current		1.00	μA	V _{CE} = 10.0 V, I _F = 0, E ₀ ≤ 0.100 μW/cm ²
Combined					
I _{C(O)}	On-State Collector Current	2.0		mA	I _F = 40 mA, V _{CE} = 5.0 V, d = 0.200 in. (5.08 mm) ⁽¹⁾ . See Note 3.
I _{CX}	Crosstalk		20	μA	I _F = 40 mA, V _{CE} = 5.0 V, No Reflecting Surface. See Note 5.
V _{CE(SAT)}	Collector-Emitter Saturation Voltage		1.10	V	I _F = 40 mA, I _C = 1 mA, d = 0.200(5.08mm) ⁽¹⁾⁽²⁾⁽³⁾ .

Typical Performance Curves

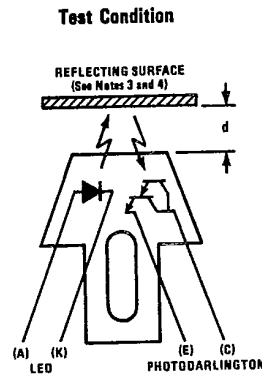
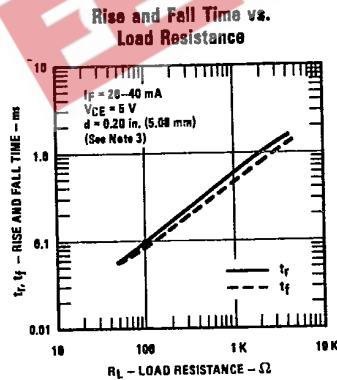
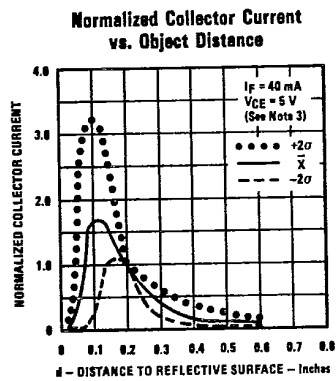
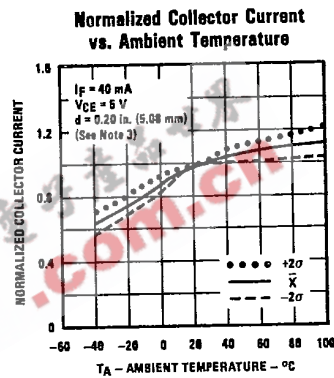
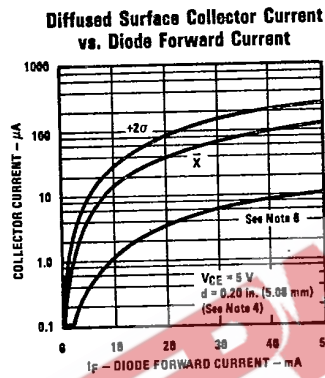
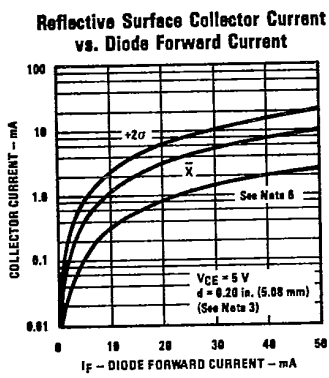

TRW reserves the right to make changes at any time in order to improve design and to supply the best product possible.
 Optoelectronics Division, TRW Electronic Components Group, 1215 W. Crosby Rd., Carrollton, TX 75006 (214) 323-2200, TLX 6716032 or 215049
 © TRW Inc. 1985, 1982. TRW is the name and mark of TRW Inc. Printed in U.S.A.