

OPA353
OPA2353
OPA4353

For most current data sheet and other product information, visit www.burr-brown.com

High-Speed, Single-Supply, Rail-to-Rail OPERATIONAL AMPLIFIERS

MicroAmplifier™ Series

FEATURES

- RAIL-TO-RAIL INPUT
- RAIL-TO-RAIL OUTPUT (within 10mV)
- WIDE BANDWIDTH: 44MHz
- HIGH SLEW RATE: 22V/μs
- LOW NOISE: 5nV/√Hz
- LOW THD+NOISE: 0.0006%
- UNITY-GAIN STABLE
- MicroSIZE PACKAGES
- SINGLE, DUAL, AND QUAD

APPLICATIONS

- CELL PHONE PA CONTROL LOOPS
- DRIVING A/D CONVERTERS
- VIDEO PROCESSING
- DATA ACQUISITION
- PROCESS CONTROL
- AUDIO PROCESSING
- COMMUNICATIONS
- ACTIVE FILTERS
- TEST EQUIPMENT

DESCRIPTION

OPA353 series rail-to-rail CMOS operational amplifiers are designed for low cost, miniature applications. They are optimized for low voltage, single-supply operation. Rail-to-rail input/output, low noise (5nV/√Hz), and high speed operation (44MHz, 22V/μs) make them ideal for driving sampling analog-to-digital converters. They are also well suited for cell phone PA control loops and video processing (75Ω drive capability) as well as audio and general purpose applications. Single, dual, and quad versions have identical specifications for design flexibility.

The OPA353 series operates on a single supply as low as 2.5V with an input common-mode voltage range that

extends 300mV beyond the supply rails. Output voltage swing is to within 10mV of the supply rails with a 10kΩ load. Dual and quad designs feature completely independent circuitry for lowest crosstalk and freedom from interaction.

The single (OPA353) packages are the tiny 5-lead SOT-23-5 surface mount and SO-8 surface mount. The dual (OPA2353) comes in the miniature MSOP-8 surface mount and SO-8 surface mount. The quad (OPA4353) packages are the space-saving SSOP-16 surface mount and SO-14 surface mount. All are specified from -40°C to +85°C and operate from -55°C to +125°C.

SPICE Model available at www.burr-brown.com

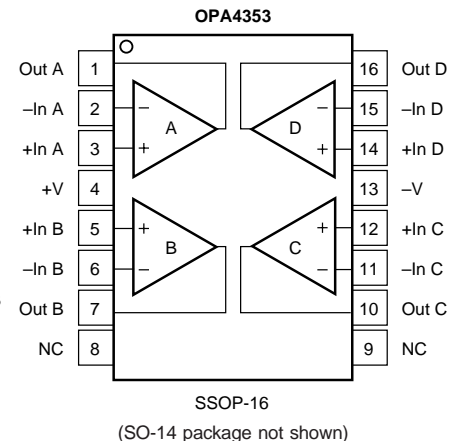
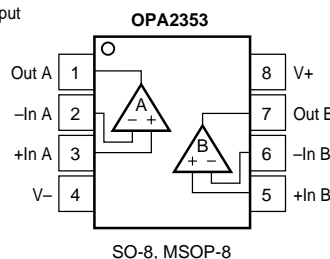
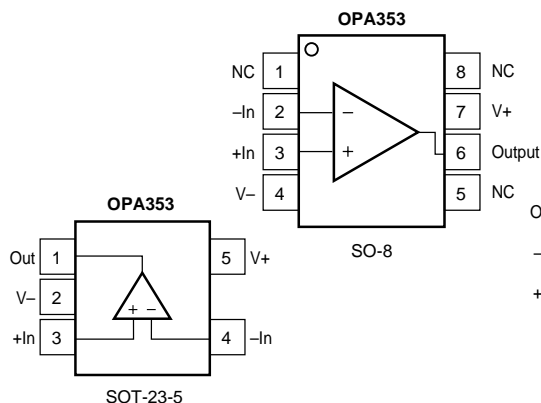

International Airport Industrial Park • Mailing Address: PO Box 11400, Tucson, AZ 85734 • Street Address: 6730 S. Tucson Blvd., Tucson, AZ 85706 • Tel: (520) 746-1111
Twx: 910-952-1111 • Internet: <http://www.burr-brown.com/> • Cable: BBRCORP • Telex: 066-6491 • FAX: (520) 889-1510 • Immediate Product Info: (800) 548-6132

SPECIFICATIONS: $V_S = 2.7V$ to $5.5V$

At $T_A = +25^\circ C$, $R_L = 1k\Omega$ connected to $V_S/2$ and $V_{OUT} = V_S/2$, unless otherwise noted.

Boldface limits apply over the specified temperature range, $T_A = -40^\circ C$ to $+85^\circ C$. $V_S = 5V$.

PARAMETER	CONDITION	OPA353NA, UA OPA2353EA, UA OPA4353EA, UA			UNITS
		MIN	TYP ⁽¹⁾	MAX	
OFFSET VOLTAGE Input Offset Voltage V_{OS} $T_A = -40^\circ C$ to $+85^\circ C$ vs Temperature vs Power Supply Rejection Ratio PSRR $T_A = -40^\circ C$ to $+85^\circ C$ Channel Separation (dual, quad)	$V_S = 5V$ $T_A = -40^\circ C$ to $+85^\circ C$ $V_S = 2.7V$ to $5.5V$, $V_{CM} = 0V$ $V_S = 2.7V$ to $5.5V$, $V_{CM} = 0V$ dc		± 3 ± 5 40 0.15	± 8 ± 10 150 175	mV mV $\mu V/^\circ C$ $\mu V/V$ $\mu V/V$ $\mu V/V$
INPUT BIAS CURRENT Input Bias Current I_B $T_A = -40^\circ C$ to $+85^\circ C$ Input Offset Current I_{OS}			± 0.5 See Typical Curve ± 0.5	± 10 ± 10	pA pA
NOISE Input Voltage Noise, $f = 100Hz$ to $400kHz$ Input Voltage Noise Density, $f = 10kHz$ $f = 100kHz$ Current Noise Density, $f = 10kHz$			4 7 5 4		μV_{rms} nV/\sqrt{Hz} nV/\sqrt{Hz} fA/\sqrt{Hz}
INPUT VOLTAGE RANGE Common-Mode Voltage Range V_{CM} Common-Mode Rejection Ratio CMRR $T_A = -40^\circ C$ to $+85^\circ C$	$-0.1V < V_{CM} < (V+) - 2.4V$ $V_S = 5V$, $-0.1V < V_{CM} < 5.1V$ $V_S = 5V$, $-0.1V < V_{CM} < 5.1V$	-0.1 76 60 58	86 74	$(V+) + 0.1$	V dB dB dB
INPUT IMPEDANCE Differential Common-Mode			$10^{13} \parallel 2.5$ $10^{13} \parallel 6.5$		$\Omega \parallel pF$ $\Omega \parallel pF$
OPEN-LOOP GAIN Open-Loop Voltage Gain A_{OL} $T_A = -40^\circ C$ to $+85^\circ C$ $T_A = -40^\circ C$ to $+85^\circ C$	$R_L = 10k\Omega$, $50mV < V_O < (V+) - 50mV$ $R_L = 10k\Omega$, $50mV < V_O < (V+) - 50mV$ $R_L = 1k\Omega$, $200mV < V_O < (V+) - 200mV$ $R_L = 1k\Omega$, $200mV < V_O < (V+) - 200mV$	100 100 100 100	122 120		dB dB dB dB
FREQUENCY RESPONSE Gain-Bandwidth Product GBW Slew Rate SR Settling Time, 0.1% 0.01% Overload Recovery Time Total Harmonic Distortion + Noise THD+N Differential Gain Error Differential Phase Error	$C_L = 100pF$ $G = 1$ $G = 1$ $G = \pm 1$, 2V Step $G = \pm 1$, 2V Step $V_{IN} \cdot G = V_S$ $R_L = 600\Omega$, $V_O = 2.5V_{pp-p(2)}$, $G = 1$, $f = 1kHz$ $G = 2$, $R_L = 600\Omega$, $V_O = 1.4V^{(3)}$ $G = 2$, $R_L = 600\Omega$, $V_O = 1.4V^{(3)}$		44 22 0.22 0.5 0.1 0.0006 0.17 0.17		MHz V/ μs μs μs μs % % deg
OUTPUT Voltage Output Swing from Rail ⁽⁴⁾ V_{OUT} $T_A = -40^\circ C$ to $+85^\circ C$ $T_A = -40^\circ C$ to $+85^\circ C$ Output Current I_{OUT} Short-Circuit Current I_{SC} Capacitive Load Drive C_{LOAD}	$R_L = 10k\Omega$, $A_{OL} \geq 100dB$ $R_L = 10k\Omega$, $A_{OL} \geq 100dB$ $R_L = 1k\Omega$, $A_{OL} \geq 100dB$ $R_L = 1k\Omega$, $A_{OL} \geq 100dB$		10 25 $\pm 40^{(5)}$ ± 80	50 50 200 200	mV mV mV mV mA mA
POWER SUPPLY Operating Voltage Range V_S Minimum Operating Voltage Quiescent Current (per amplifier) I_Q $T_A = -40^\circ C$ to $+85^\circ C$	$T_A = -40^\circ C$ to $+85^\circ C$ $I_O = 0$ $I_O = 0$	2.7	2.5 5.2	5.5 8 9	V V mA mA
TEMPERATURE RANGE Specified Range Operating Range Storage Range Thermal Resistance θ_{JA} SOT-23-5 MSOP-8 Surface Mount SO-8 Surface Mount SSOP-16 Surface Mount SO-14 Surface Mount		-40 -55 -55		$+85$ $+125$ $+125$	$^\circ C$ $^\circ C$ $^\circ C$ $^\circ C/W$ $^\circ C/W$ $^\circ C/W$ $^\circ C/W$ $^\circ C/W$

NOTES: (1) $V_S = +5V$. (2) $V_{OUT} = 0.25V$ to $2.75V$. (3) NTSC signal generator used. See Figure 6 for test circuit. (4) Output voltage swings are measured between the output and power supply rails. (5) See typical performance curve, "Output Voltage Swing vs Output Swing."

PIN CONFIGURATION

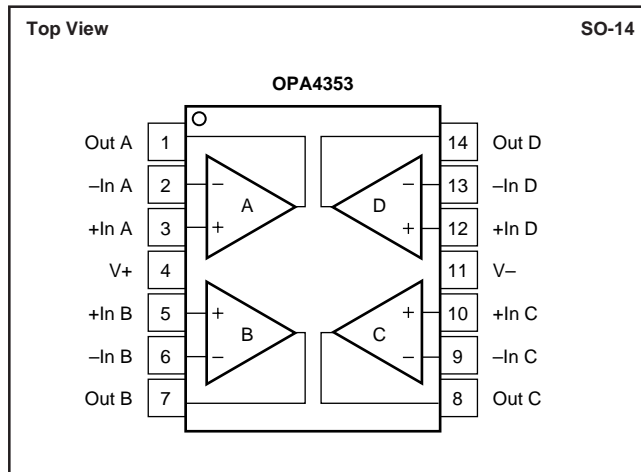

ELECTROSTATIC DISCHARGE SENSITIVITY

This integrated circuit can be damaged by ESD. Burr-Brown recommends that all integrated circuits be handled with appropriate precautions. Failure to observe proper handling and installation procedures can cause damage.

ESD damage can range from subtle performance degradation to complete device failure. Precision integrated circuits may be more susceptible to damage because very small parametric changes could cause the device not to meet its published specifications.

ABSOLUTE MAXIMUM RATINGS⁽¹⁾

Supply Voltage	5.5V
Signal Input Terminals, Voltage ⁽²⁾	(V-) - 0.3V to (V+) + 0.3V
Current ⁽²⁾	10mA
Output Short-Circuit ⁽³⁾	Continuous
Operating Temperature	-55°C to +125°C
Storage Temperature	-55°C to +125°C
Junction Temperature	150°C
Lead Temperature (soldering, 10s)	300°C

NOTES: (1) Stresses above these ratings may cause permanent damage. Exposure to absolute maximum conditions for extended periods may degrade device reliability. (2) Input terminals are diode-clamped to the power supply rails. Input signals that can swing more than 0.3V beyond the supply rails should be current-limited to 10mA or less. (3) Short circuit to ground, one amplifier per package.

PACKAGE/ORDERING INFORMATION

PRODUCT	PACKAGE	PACKAGE DRAWING NUMBER ⁽¹⁾	SPECIFIED TEMPERATURE RANGE	PACKAGE MARKING	ORDERING NUMBER ⁽²⁾	TRANSPORT MEDIA
Single						
OPA353NA	5-Lead SOT-23-5	331	-40°C to +85°C	D53	OPA353NA/250	Tape and Reel
OPA353UA	SO-8 Surface Mount	182	-40°C to +85°C	OPA353UA	OPA353NA/3K OPA353UA OPA353UA/2K5	Tape and Reel Tape and Reel Rails Tape and Reel
Dual						
OPA2353EA	MSOP-8 Surface Mount	337	-40°C to +85°C	E53	OPA2353EA/250	Tape and Reel
OPA2353UA	SO-8 Surface Mount	182	-40°C to +85°C	OPA2353UA	OPA2353EA/2K5 OPA2353UA OPA2353UA/2K5	Tape and Reel Tape and Reel Rails Tape and Reel
Quad						
OPA4353EA	SSOP-16 Surface Mount	322	-40°C to +85°C	OPA4353EA	OPA4353EA/250	Tape and Reel
OPA4353UA	SO-14 Surface Mount	235	-40°C to +85°C	OPA4353UA	OPA4353EA/2K5 OPA4353UA OPA4353UA/2K5	Tape and Reel Tape and Reel Rails Tape and Reel

NOTES: (1) For detailed drawing and dimension table, please see end of data sheet, or Appendix C of Burr-Brown IC Data Book. (2) Models with a slash (/) are available only in Tape and Reel in the quantities indicated (e.g., /2K5 indicates 2500 devices per reel). Ordering 2500 pieces of "OPA2353EA/2K5" will get a single 2500-piece Tape and Reel. For detailed Tape and Reel mechanical information, refer to Appendix B of Burr-Brown IC Data Book.

The information provided herein is believed to be reliable; however, BURR-BROWN assumes no responsibility for inaccuracies or omissions. BURR-BROWN assumes no responsibility for the use of this information, and all use of such information shall be entirely at the user's own risk. Prices and specifications are subject to change without notice. No patent rights or licenses to any of the circuits described herein are implied or granted to any third party. BURR-BROWN does not authorize or warrant any BURR-BROWN product for use in life support devices and/or systems.

TYPICAL PERFORMANCE CURVES

At $T_A = +25^\circ\text{C}$, $V_S = +5\text{V}$, and $R_L = 1\text{k}\Omega$ connected to $V_S/2$, unless otherwise noted.

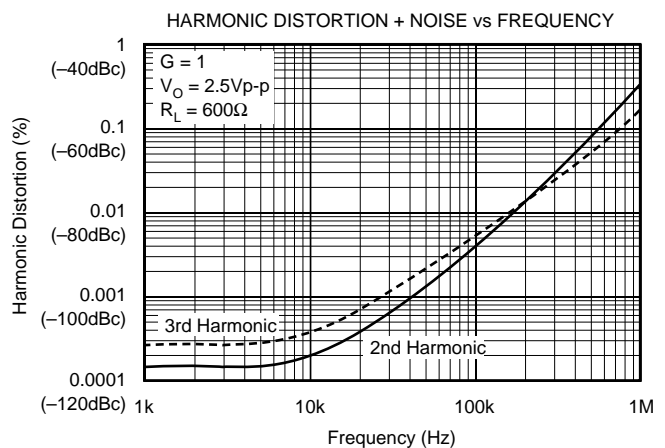
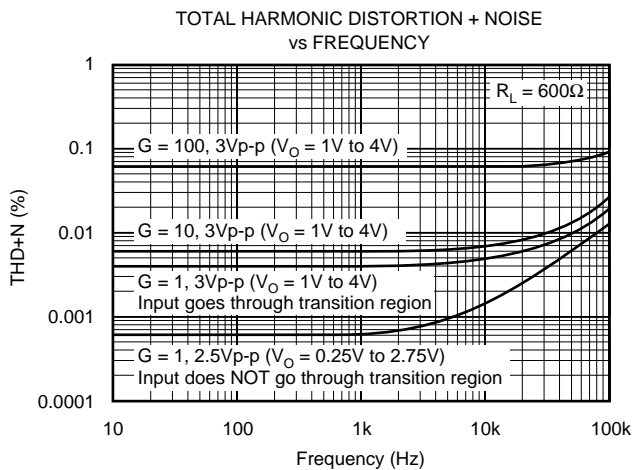
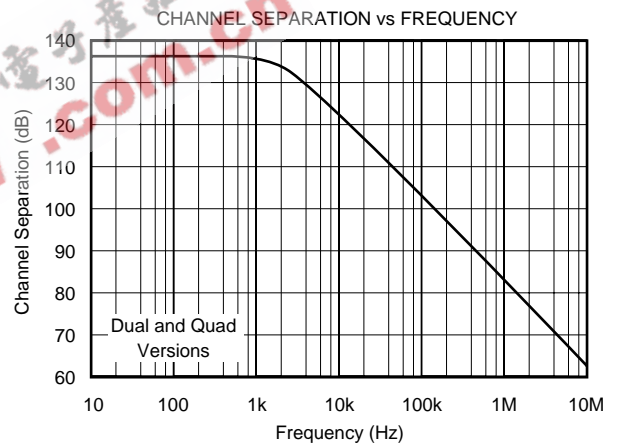
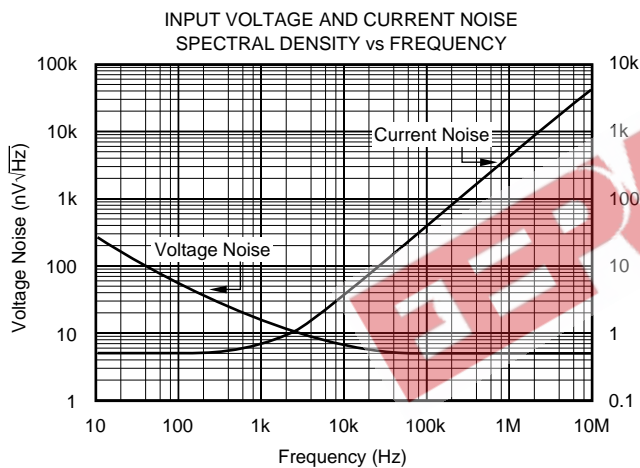
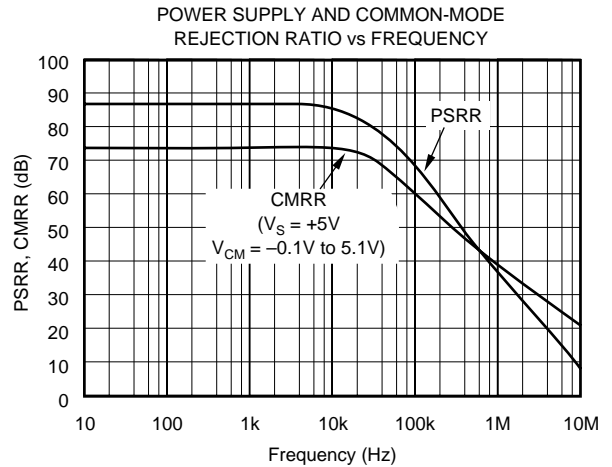
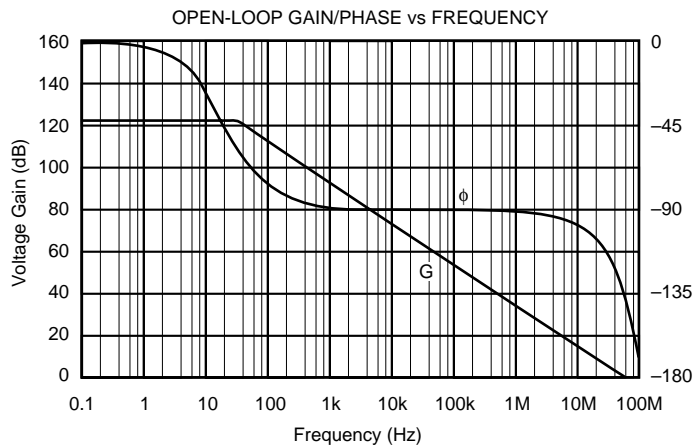

TYPICAL PERFORMANCE CURVES (CONT)

At $T_A = +25^\circ\text{C}$, $V_S = +5\text{V}$, and $R_L = 1\text{k}\Omega$ connected to $V_S/2$, unless otherwise noted.

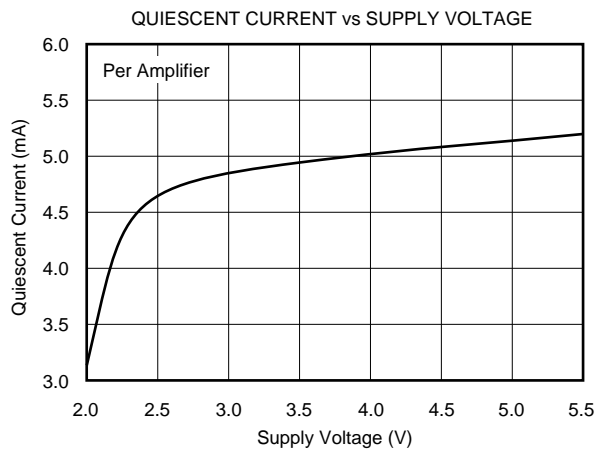
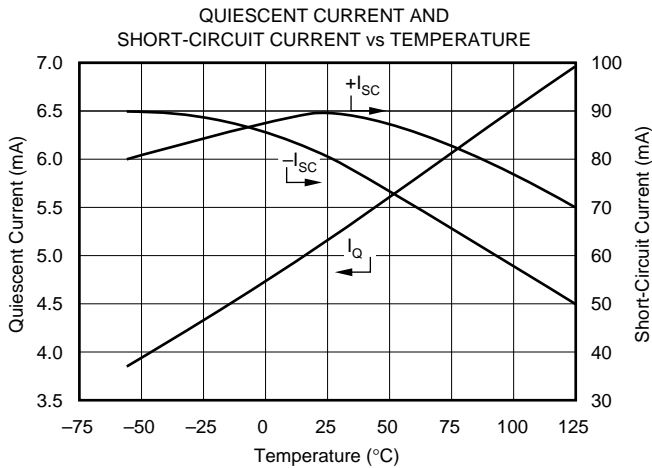
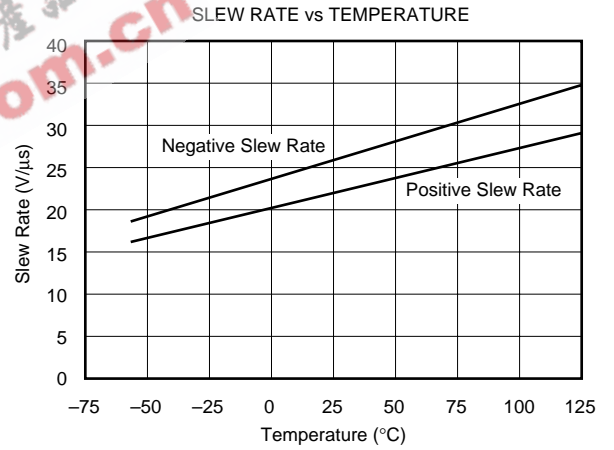
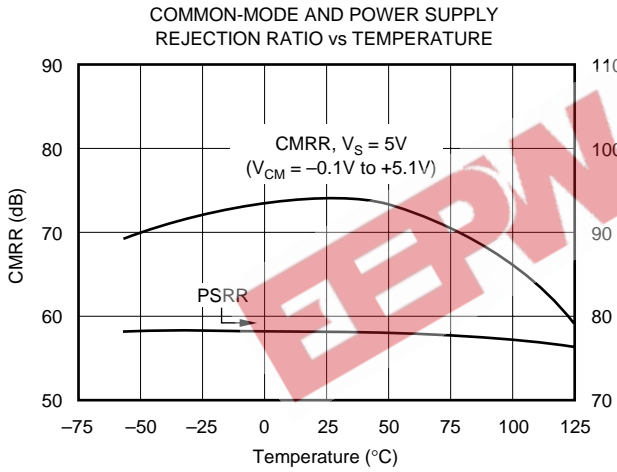
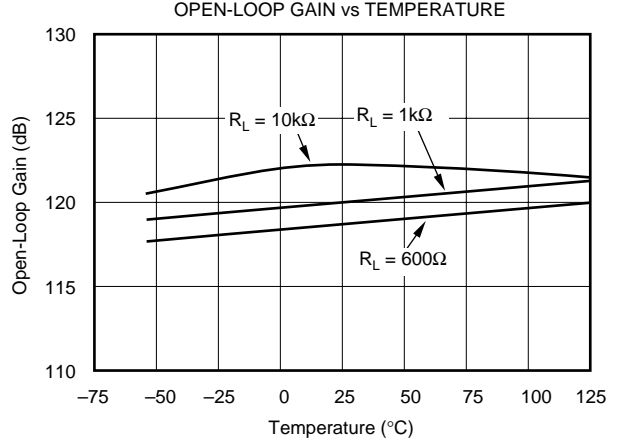
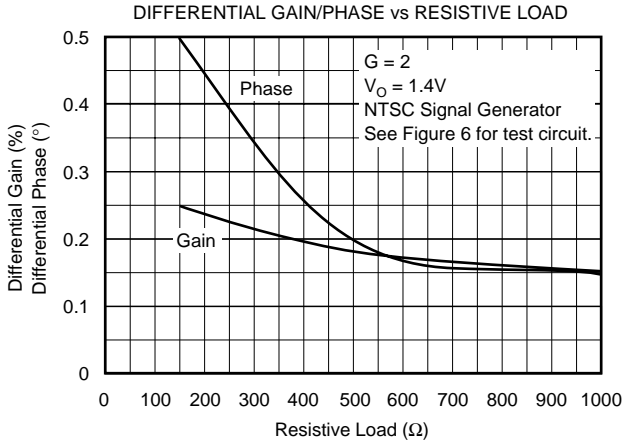

TYPICAL PERFORMANCE CURVES (CONT)

At $T_A = +25^\circ\text{C}$, $V_S = +5\text{V}$, and $R_L = 1\text{k}\Omega$ connected to $V_S/2$, unless otherwise noted.

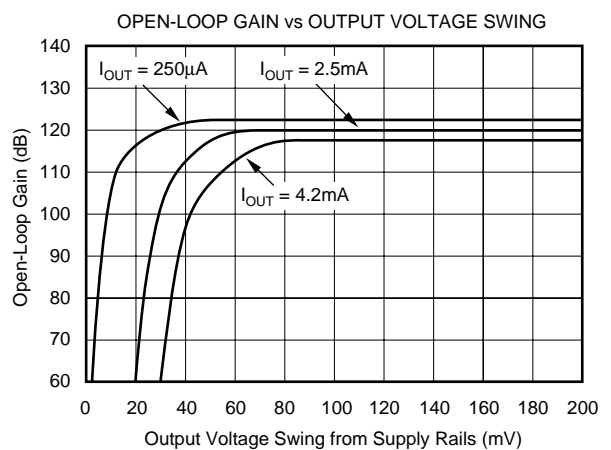
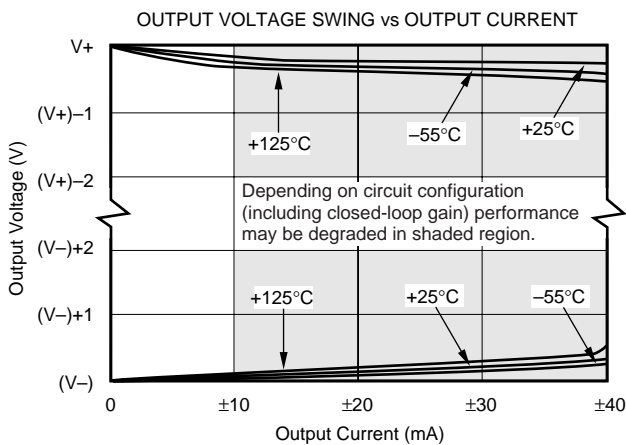
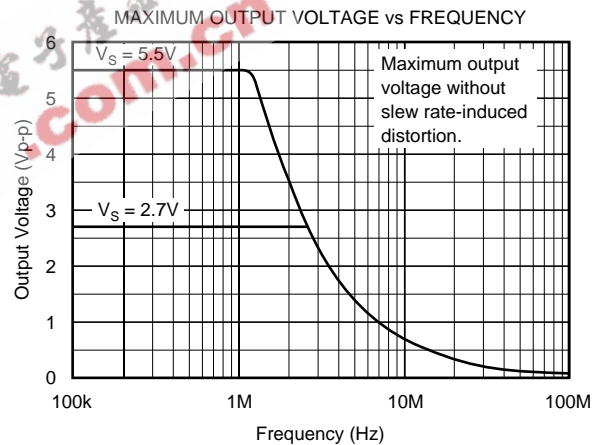
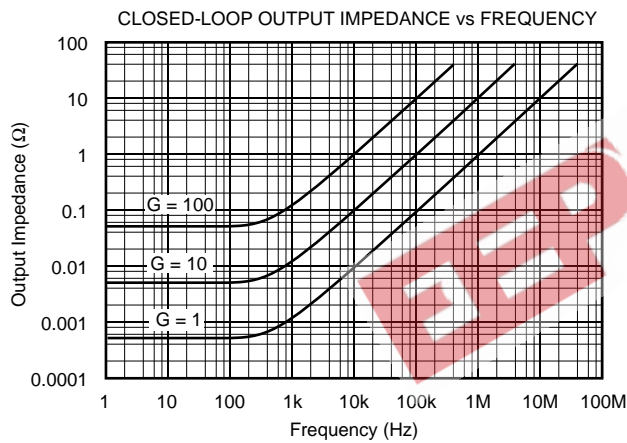
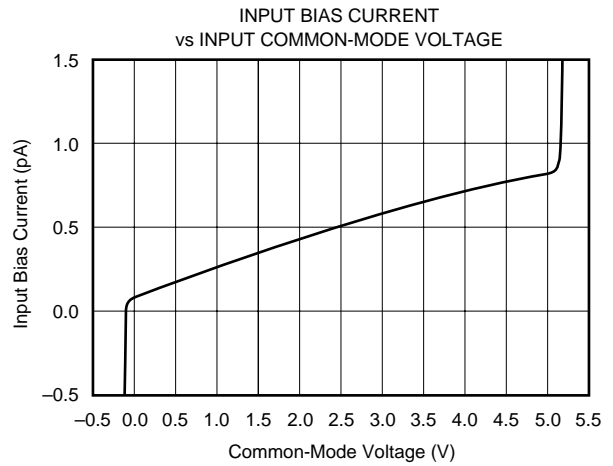
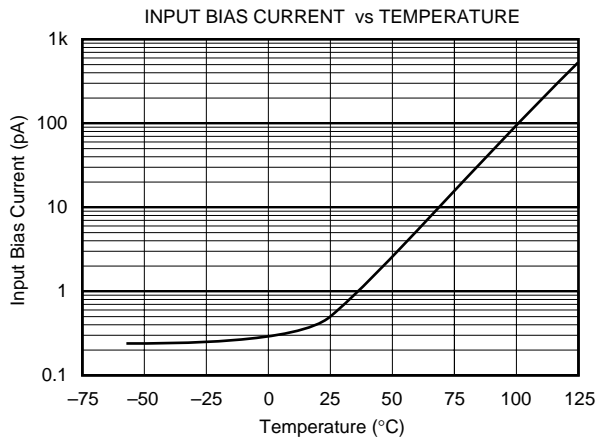

TYPICAL PERFORMANCE CURVES (CONT)

At $T_A = +25^\circ\text{C}$, $V_S = +5\text{V}$, and $R_L = 1\text{k}\Omega$ connected to $V_G/2$, unless otherwise noted.

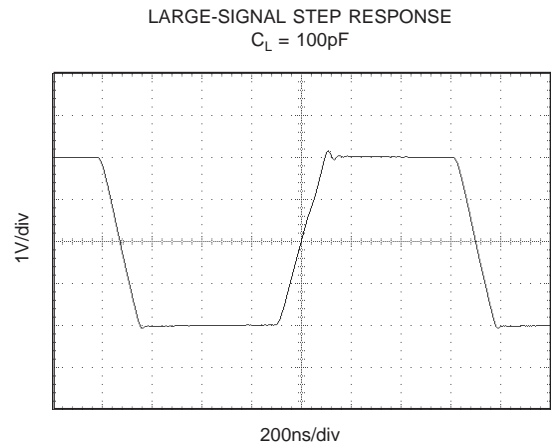
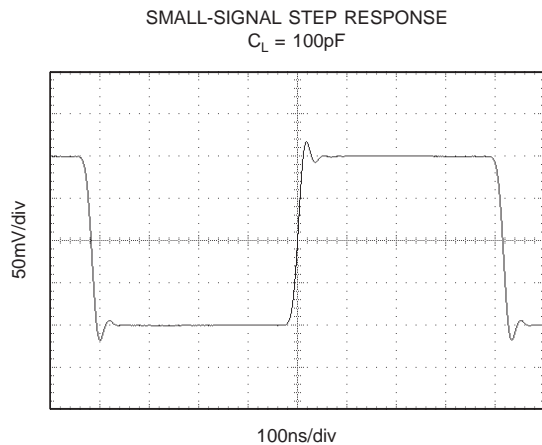
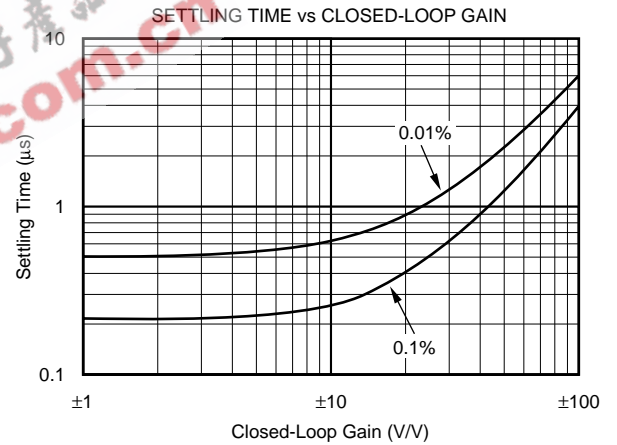
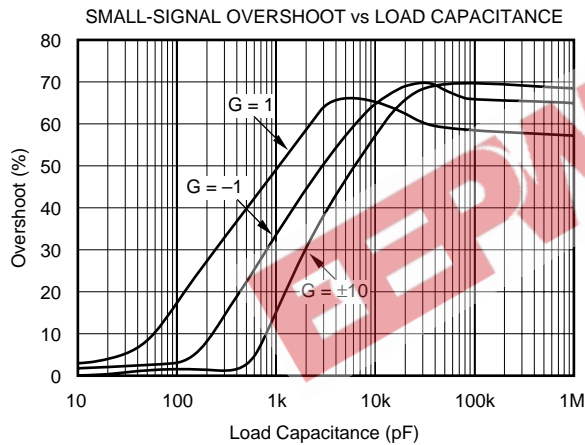
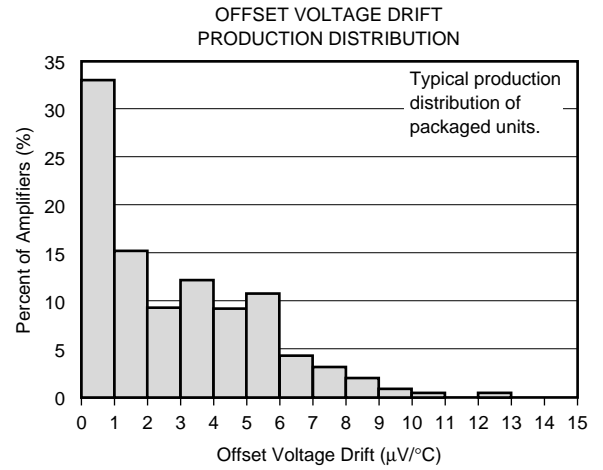
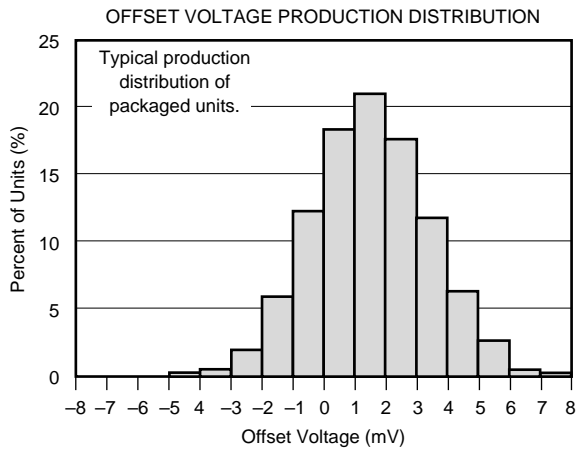

APPLICATIONS INFORMATION

OPA353 series op amps are fabricated on a state-of-the-art 0.6 micron CMOS process. They are unity-gain stable and suitable for a wide range of general purpose applications. Rail-to-rail input/output make them ideal for driving sampling A/D converters. They are well suited for controlling the output power in cell phones. These applications often require high speed and low noise. In addition, the OPA353 series offers a low cost solution for general purpose and consumer video applications (75Ω drive capability).

Excellent ac performance makes the OPA353 series well suited for audio applications. Their bandwidth, slew rate, low noise ($5\text{nV}/\sqrt{\text{Hz}}$), low THD (0.0006%), and small package options are ideal for these applications. The class AB output stage is capable of driving 600Ω loads connected to any point between V+ and ground.

Rail-to-rail input and output swing significantly increases dynamic range, especially in low voltage supply applications. Figure 1 shows the input and output waveforms for

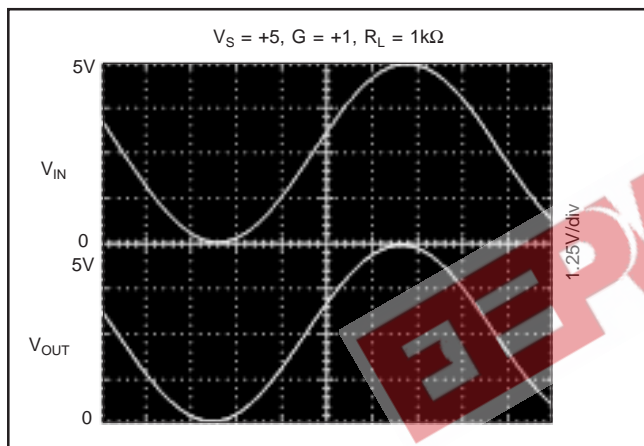

FIGURE 1. Rail-to-Rail Input and Output.

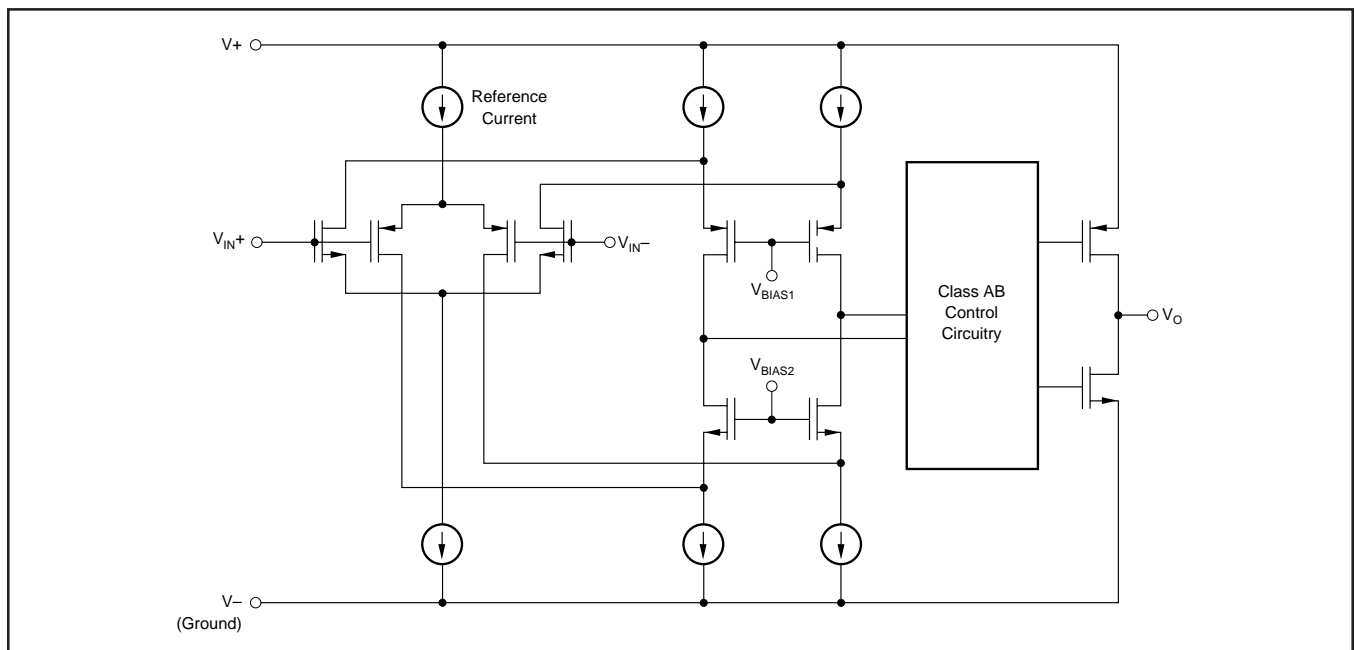

FIGURE 2. Simplified Schematic.

the OPA353 in unity-gain configuration. Operation is from a single +5V supply with a 1kΩ load connected to $V_S/2$. The input is a 5Vp-p sinusoid. Output voltage is approximately 4.95Vp-p.

Power supply pins should be bypassed with 0.01μF ceramic capacitors.

OPERATING VOLTAGE

OPA353 series op amps are fully specified from +2.7V to +5.5V. However, supply voltage may range from +2.5V to +5.5V. Parameters are guaranteed over the specified supply range—a unique feature of the OPA353 series. In addition, many specifications apply from -40°C to $+85^\circ\text{C}$. Most behavior remains virtually unchanged throughout the full operating voltage range. Parameters which vary significantly with operating voltages or temperature are shown in the typical performance curves.

RAIL-TO-RAIL INPUT

The guaranteed input common-mode voltage range of the OPA353 series extends 100mV beyond the supply rails. This is achieved with a complementary input stage—an N-channel input differential pair in parallel with a P-channel differential pair (see Figure 2). The N-channel pair is active for input voltages close to the positive rail, typically $(V+) - 1.8\text{V}$ to 100mV above the positive supply, while the P-channel pair is on for inputs from 100mV below the negative supply to approximately $(V+) - 1.8\text{V}$. There is a small transition region, typically $(V+) - 2\text{V}$ to $(V+) - 1.6\text{V}$, in which both pairs are on. This 400mV transition region can vary $\pm 400\text{mV}$ with process variation. Thus, the transition region (both input stages on) can range from $(V+) - 2.4\text{V}$ to $(V+) - 2.0\text{V}$ on the low end, up to $(V+) - 1.6\text{V}$ to $(V+) - 1.2\text{V}$ on the high end.

A double-folded cascode adds the signal from the two input pairs and presents a differential signal to the class AB output stage. Normally, input bias current is approximately 500fA. However, large inputs (greater than 300mV beyond the supply rails) can turn on the OPA353's input protection diodes, causing excessive current to flow in or out of the input pins. Momentary voltages greater than 300mV beyond the power supply can be tolerated if the current on the input pins is limited to 10mA. This is easily accomplished with an input resistor as shown in Figure 3. Many input signals are inherently current-limited to less than 10mA, therefore, a limiting resistor is not required.

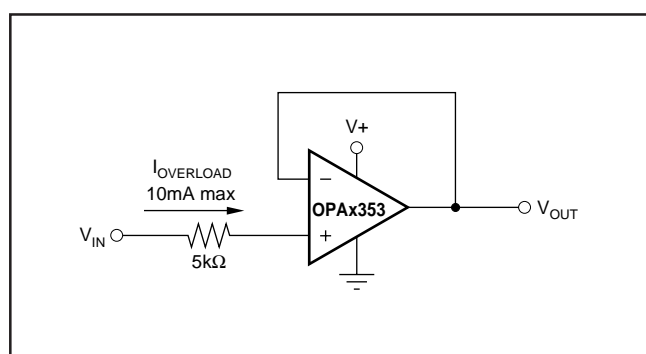

FIGURE 3. Input Current Protection for Voltages Exceeding the Supply Voltage.

RAIL-TO-RAIL OUTPUT

A class AB output stage with common-source transistors is used to achieve rail-to-rail output. For light resistive loads (>10kΩ), the output voltage swing is typically ten millivolts from the supply rails. With heavier resistive loads (600Ω to 10kΩ), the output can swing to within a few tens of millivolts from the supply rails and maintain high open-loop gain. See the typical performance curves “Output Voltage Swing vs Output Current” and “Open-Loop Gain vs Output Voltage.”

CAPACITIVE LOAD AND STABILITY

OPA353 series op amps can drive a wide range of capacitive loads. However, all op amps under certain conditions may become unstable. Op amp configuration, gain, and load value are just a few of the factors to consider when determining stability. An op amp in unity gain configuration is the most susceptible to the effects of capacitive load. The capacitive load reacts with the op amp's output impedance, along with any additional load resistance, to create a pole in the small-signal response which degrades the phase margin.

In unity gain, OPA353 series op amps perform well with large capacitive loads. Increasing gain enhances the amplifier's ability to drive more capacitance. The typical performance curve “Small-Signal Overshoot vs Capacitive Load” shows performance with a 1kΩ resistive load. Increasing load resistance improves capacitive load drive capability.

FEEDBACK CAPACITOR IMPROVES RESPONSE

For optimum settling time and stability with high-impedance feedback networks, it may be necessary to add a feedback capacitor across the feedback resistor, R_F , as shown in Figure 4. This capacitor compensates for the zero created by the feedback network impedance and the OPA353's input capacitance (and any parasitic layout capacitance). The effect becomes more significant with higher impedance networks.

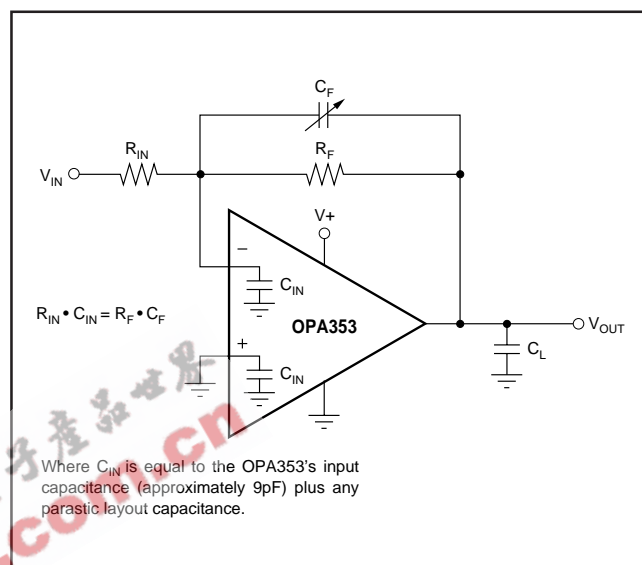

FIGURE 4. Feedback Capacitor Improves Dynamic Performance.

It is suggested that a variable capacitor be used for the feedback capacitor since input capacitance may vary between op amps and layout capacitance is difficult to determine. For the circuit shown in Figure 4, the value of the variable feedback capacitor should be chosen so that the input resistance times the input capacitance of the OPA353 (typically 9pF) plus the estimated parasitic layout capacitance equals the feedback capacitor times the feedback resistor:

$$R_{IN} \cdot C_{IN} = R_F \cdot C_F$$

where C_{IN} is equal to the OPA353's input capacitance (sum of differential and common-mode) plus the layout capacitance. The capacitor can be varied until optimum performance is obtained.

DRIVING A/D CONVERTERS

OPA353 series op amps are optimized for driving medium speed (up to 500kHz) sampling A/D converters. However, they also offer excellent performance for higher speed converters. The OPA353 series provides an effective means of buffering the A/D's input capacitance and resulting charge injection while providing signal gain. For applications requiring high accuracy, the OPA350 series is recommended.

Figure 5 shows the OPA353 driving an ADS7861. The ADS7861 is a dual, 12-bit, 500kHz sampling converter in the small SSOP-24 package. When used with the miniature package options of the OPA353 series, the combination is ideal for space-limited and low power applications. For further information consult the ADS7861 data sheet.

OUTPUT IMPEDANCE

The low frequency open-loop output impedance of the OPA353's common-source output stage is approximately 1kΩ. When the op amp is connected with feedback, this value is reduced significantly by the loop gain of the op amp. For example, with 122dB of open-loop gain, the output impedance is reduced in unity-gain to less than 0.001Ω. For each decade rise in the closed-loop gain, the loop gain is reduced by the same amount which results in a ten-fold increase in output impedance (see the typical performance curve, "Output Impedance vs Frequency").

At higher frequencies, the output impedance will rise as the open-loop gain of the op amp drops. However, at these frequencies the output also becomes capacitive due to parasitic capacitance. This prevents the output impedance

from becoming too high, which can cause stability problems when driving capacitive loads. As mentioned previously, the OPA353 has excellent capacitive load drive capability for an op amp with its bandwidth.

VIDEO LINE DRIVER

Figure 6 shows a circuit for a single supply, G = 2 composite video line driver. The synchronized outputs of a composite video line driver extend below ground. As shown, the input to the op amp should be ac-coupled and shifted positively to provide adequate signal swing to account for these negative signals in a single-supply configuration.

The input is terminated with a 75Ω resistor and ac-coupled with a 47μF capacitor to a voltage divider that provides the dc bias point to the input. In Figure 6, this point is approximately (V-) + 1.7V. Setting the optimal bias point requires some understanding of the nature of composite video signals. For best performance, one should be careful to avoid the distortion caused by the transition region of the OPA353's complementary input stage. Refer to the discussion of rail-to-rail input.

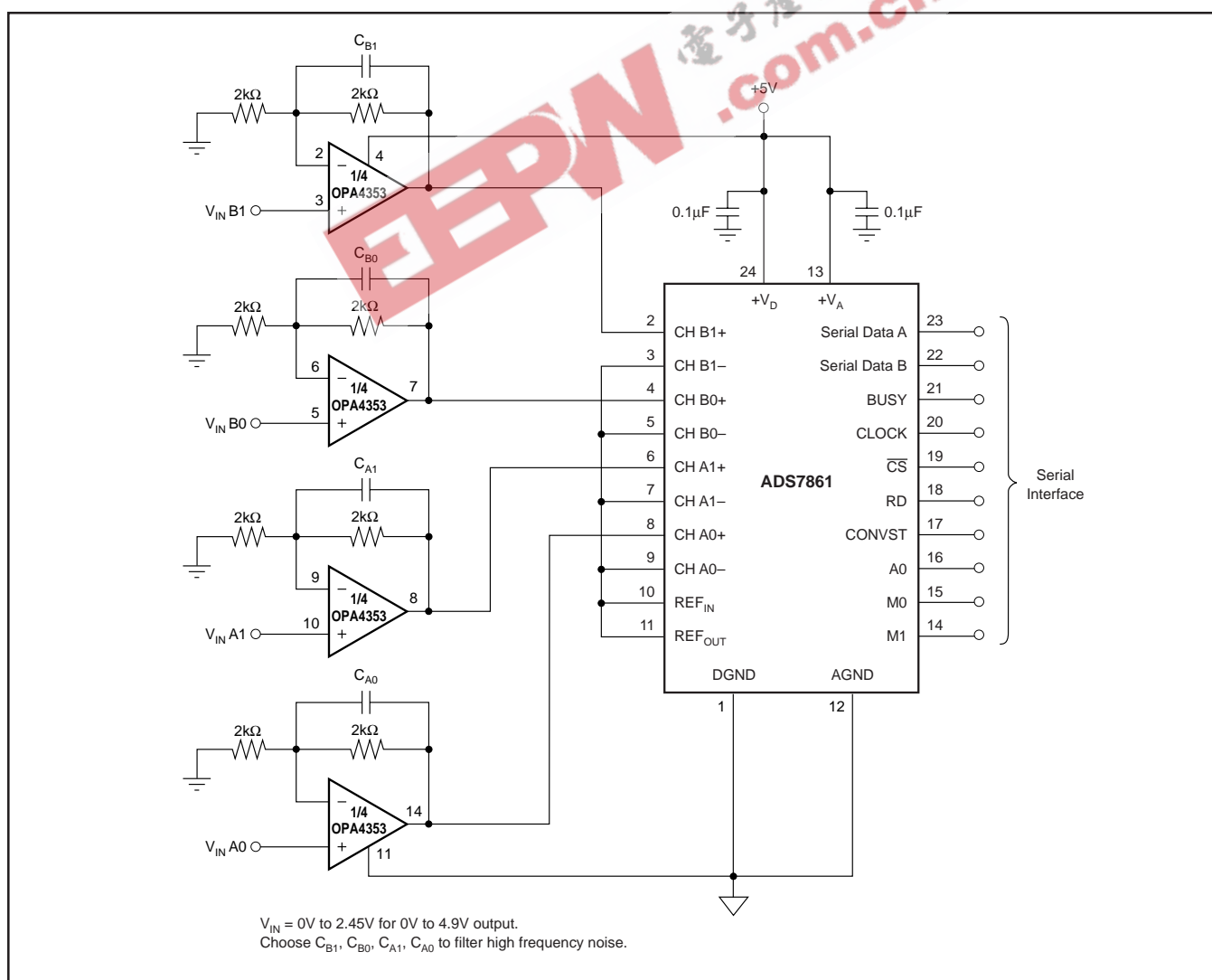

FIGURE 5. OPA4353 Driving Sampling A/D Converter.

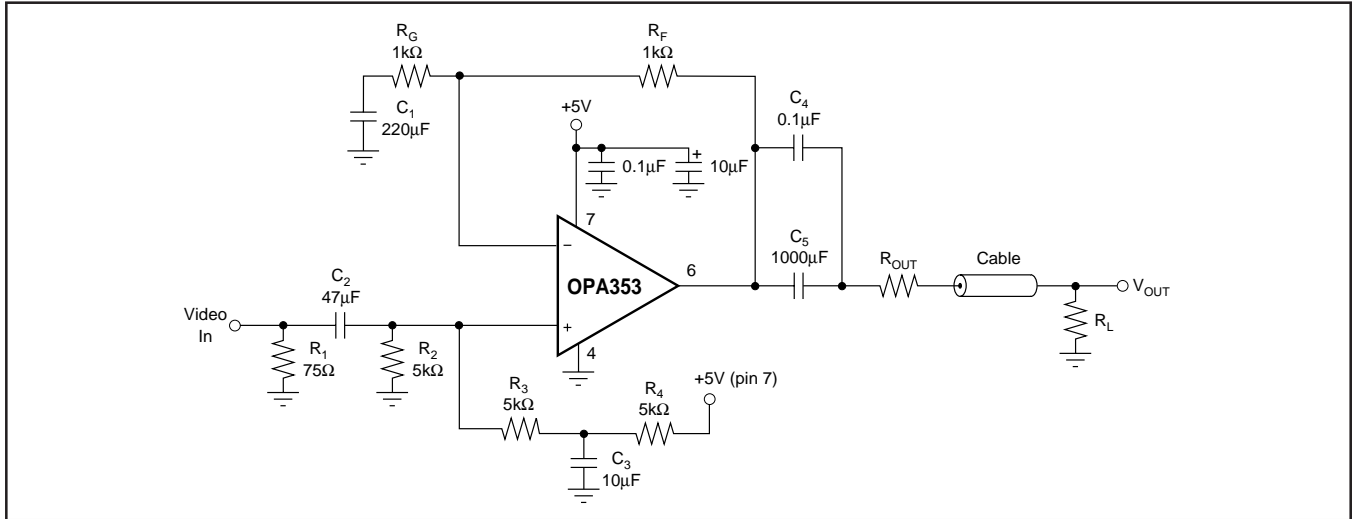

FIGURE 6. Single-Supply Video Line Driver.

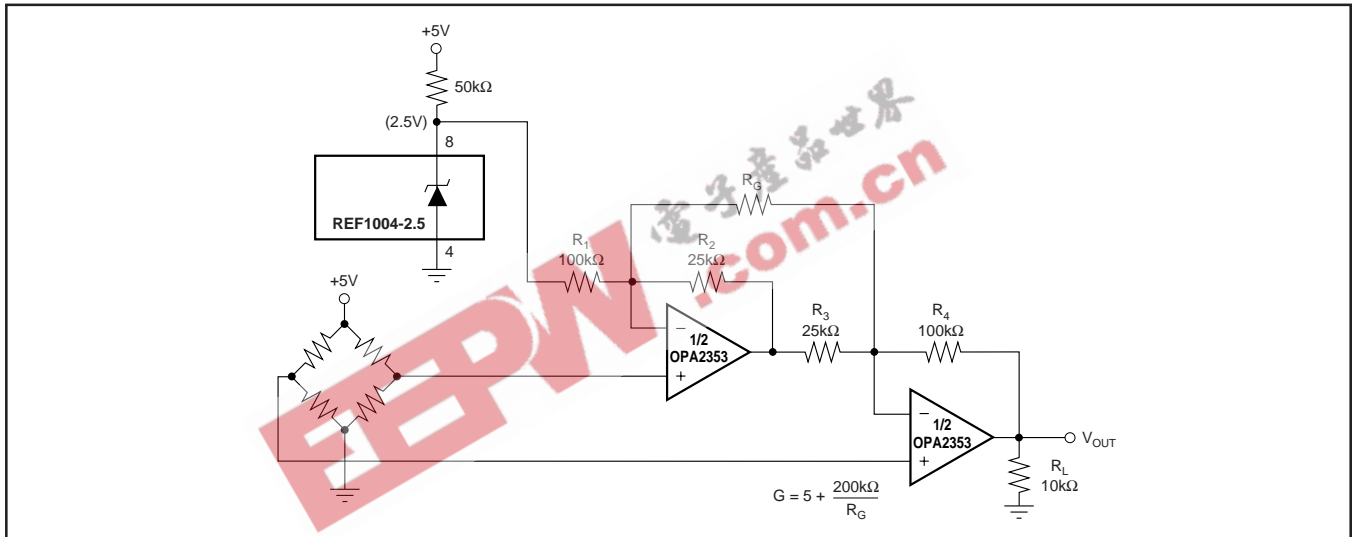

FIGURE 7. Two Op-Amp Instrumentation Amplifier With Improved High Frequency Common-Mode Rejection.

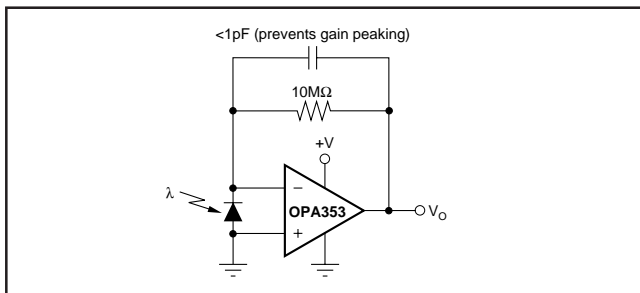

FIGURE 8. Transimpedance Amplifier.

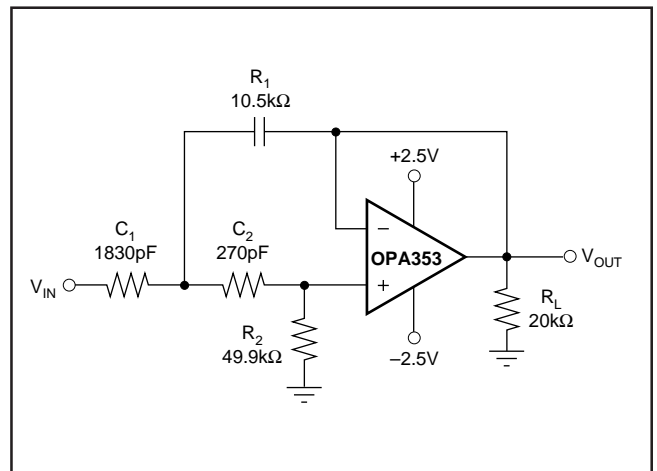

FIGURE 10. 10kHz High-Pass Filter.

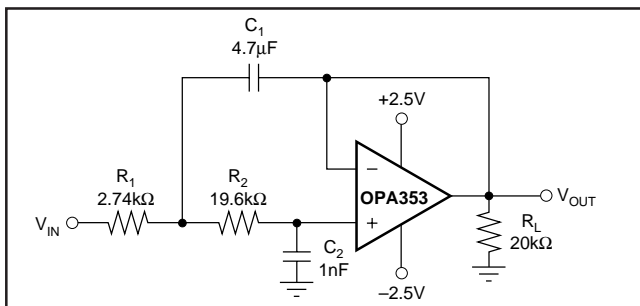

FIGURE 9. 10kHz Low-Pass Filter.

PACKAGING INFORMATION

Orderable Device	Status ⁽¹⁾	Package Type	Package Drawing	Pins	Package Qty	Eco Plan ⁽²⁾	Lead/Ball Finish	MSL Peak Temp ⁽³⁾
OPA2353EA/250	ACTIVE	MSOP	DGK	8	250	None	CU NIPDAU	Level-1-220C-UNLIM
OPA2353EA/2K5	ACTIVE	MSOP	DGK	8	2500	None	CU NIPDAU	Level-1-220C-UNLIM
OPA2353UA	ACTIVE	SOIC	D	8	100	None	CU	Level-3-220C-168 HR
OPA2353UA/2K5	ACTIVE	SOIC	D	8	2500	None	CU	Level-3-220C-168 HR
OPA353NA/250	ACTIVE	SOT-23	DBV	5	250	None	CU NIPDAU	Level-3-220C-168 HR
OPA353NA/3K	ACTIVE	SOT-23	DBV	5	3000	None	CU NIPDAU	Level-3-220C-168 HR
OPA353UA	ACTIVE	SOIC	D	8	100	None	CU	Level-3-220C-168 HR
OPA353UA/2K5	ACTIVE	SOIC	D	8	2500	None	CU	Level-3-220C-168 HR
OPA4353EA/250	ACTIVE	SSOP/ QSOP	DBQ	16	250	None	CU NIPDAU	Level-3-260C-168 HR
OPA4353EA/250G4	PREVIEW	SSOP/ QSOP	DBQ	16	250	None	Call TI	Call TI
OPA4353EA/2K5	ACTIVE	SSOP/ QSOP	DBQ	16	2500	None	CU NIPDAU	Level-3-260C-168 HR
OPA4353UA	ACTIVE	SOIC	D	14	58	None	CU SNPB	Level-3-220C-168 HR
OPA4353UA/2K5	ACTIVE	SOIC	D	14	2500	None	CU SNPB	Level-3-220C-168 HR
OPA4353UA/2K5G4	ACTIVE	SOIC	D	14	2500	None	Call TI	Call TI

⁽¹⁾ The marketing status values are defined as follows:

ACTIVE: Product device recommended for new designs.

LIFEBUY: TI has announced that the device will be discontinued, and a lifetime-buy period is in effect.

NRND: Not recommended for new designs. Device is in production to support existing customers, but TI does not recommend using this part in a new design.

PREVIEW: Device has been announced but is not in production. Samples may or may not be available.

OBSOLETE: TI has discontinued the production of the device.

⁽²⁾ Eco Plan - May not be currently available - please check <http://www.ti.com/productcontent> for the latest availability information and additional product content details.

None: Not yet available Lead (Pb-Free).

Pb-Free (RoHS): TI's terms "Lead-Free" or "Pb-Free" mean semiconductor products that are compatible with the current RoHS requirements for all 6 substances, including the requirement that lead not exceed 0.1% by weight in homogeneous materials. Where designed to be soldered at high temperatures, TI Pb-Free products are suitable for use in specified lead-free processes.

Green (RoHS & no Sb/Br): TI defines "Green" to mean "Pb-Free" and in addition, uses package materials that do not contain halogens, including bromine (Br) or antimony (Sb) above 0.1% of total product weight.

⁽³⁾ MSL, Peak Temp. -- The Moisture Sensitivity Level rating according to the JEDEC industry standard classifications, and peak solder temperature.

Important Information and Disclaimer: The information provided on this page represents TI's knowledge and belief as of the date that it is provided. TI bases its knowledge and belief on information provided by third parties, and makes no representation or warranty as to the accuracy of such information. Efforts are underway to better integrate information from third parties. TI has taken and continues to take reasonable steps to provide representative and accurate information but may not have conducted destructive testing or chemical analysis on incoming materials and chemicals. TI and TI suppliers consider certain information to be proprietary, and thus CAS numbers and other limited information may not be available for release.

In no event shall TI's liability arising out of such information exceed the total purchase price of the TI part(s) at issue in this document sold by TI to Customer on an annual basis.

IMPORTANT NOTICE

Texas Instruments Incorporated and its subsidiaries (TI) reserve the right to make corrections, modifications, enhancements, improvements, and other changes to its products and services at any time and to discontinue any product or service without notice. Customers should obtain the latest relevant information before placing orders and should verify that such information is current and complete. All products are sold subject to TI's terms and conditions of sale supplied at the time of order acknowledgment.

TI warrants performance of its hardware products to the specifications applicable at the time of sale in accordance with TI's standard warranty. Testing and other quality control techniques are used to the extent TI deems necessary to support this warranty. Except where mandated by government requirements, testing of all parameters of each product is not necessarily performed.

TI assumes no liability for applications assistance or customer product design. Customers are responsible for their products and applications using TI components. To minimize the risks associated with customer products and applications, customers should provide adequate design and operating safeguards.

TI does not warrant or represent that any license, either express or implied, is granted under any TI patent right, copyright, mask work right, or other TI intellectual property right relating to any combination, machine, or process in which TI products or services are used. Information published by TI regarding third-party products or services does not constitute a license from TI to use such products or services or a warranty or endorsement thereof. Use of such information may require a license from a third party under the patents or other intellectual property of the third party, or a license from TI under the patents or other intellectual property of TI.

Reproduction of information in TI data books or data sheets is permissible only if reproduction is without alteration and is accompanied by all associated warranties, conditions, limitations, and notices. Reproduction of this information with alteration is an unfair and deceptive business practice. TI is not responsible or liable for such altered documentation.

Resale of TI products or services with statements different from or beyond the parameters stated by TI for that product or service voids all express and any implied warranties for the associated TI product or service and is an unfair and deceptive business practice. TI is not responsible or liable for any such statements.

Following are URLs where you can obtain information on other Texas Instruments products and application solutions:

Products		Applications	
Amplifiers	amplifier.ti.com	Audio	www.ti.com/audio
Data Converters	dataconverter.ti.com	Automotive	www.ti.com/automotive
DSP	dsp.ti.com	Broadband	www.ti.com/broadband
Interface	interface.ti.com	Digital Control	www.ti.com/digitalcontrol
Logic	logic.ti.com	Military	www.ti.com/military
Power Mgmt	power.ti.com	Optical Networking	www.ti.com/opticalnetwork
Microcontrollers	microcontroller.ti.com	Security	www.ti.com/security
		Telephony	www.ti.com/telephony
		Video & Imaging	www.ti.com/video
		Wireless	www.ti.com/wireless

Mailing Address: Texas Instruments
Post Office Box 655303 Dallas, Texas 75265