



Low-Noise, High-Precision, JFET-Input, OPERATIONAL AMPLIFIER

FEATURES

- **OFFSET:** 250 μ V (max)
- **DRIFT:** 1 μ V/ $^{\circ}$ C
- **LOW NOISE:** 4.5nV/ $\sqrt{\text{Hz}}$ at 1kHz
- **BANDWIDTH:** 18MHz
- **SLEW RATE:** 22V/ μ s
- **BIAS CURRENT:** 3pA
- **QUIESCENT CURRENT:** 4.5mA/Ch
- **WIDE SUPPLY RANGE:** \pm 4V to \pm 18V
- **SINGLE PACKAGES:** MSOP-8, SO-8
- **DUAL PACKAGES:** TSSOP-8, SO-8

APPLICATIONS

- **PRECISION \pm 10V INPUT FRONT-ENDS**
- **TRANSIMPEDANCE AMPLIFIERS**
- **INTEGRATORS**
- **ACTIVE FILTERS**
- **A/D CONVERTER DRIVERS**
- **DAC OUTPUT BUFFERS**
- **HIGH-PERFORMANCE AUDIO**
- **PROCESS CONTROL**
- **TEST EQUIPMENT**
- **MEDICAL EQUIPMENT**

DESCRIPTION

The OPA827 series of JFET operational amplifiers combines outstanding dc precision with excellent ac performance. It offers 100 μ V of offset, very low drift (1 μ V/ $^{\circ}$ C) over temperature, low bias currents, and very low flicker noise of 400nV_{PP} (0.1Hz to 10Hz). It operates over a very wide supply voltage range of \pm 4V to \pm 18V on a low 4.5mA supply current. A dual version is also available for the OPA827 family.

Excellent ac characteristics, such as 18MHz gain bandwidth (GBW) and 22V/ μ s slew rate, and precision dc characteristics make the OPA827 series well-suited for a wide range of applications such as 16- to 18-bit data acquisition systems, transimpedance (I/V-conversion) amplifiers, filters, precision \pm 10V front-ends, and professional audio applications.

The single version (OPA827) is available in both MSOP-8 and standard SO-8 surface-mount packages. The dual version (OPA2827) is available in the small TSSOP-8 and in the standard SO-8 packages. All versions are specified from -40° C to $+125^{\circ}$ C.

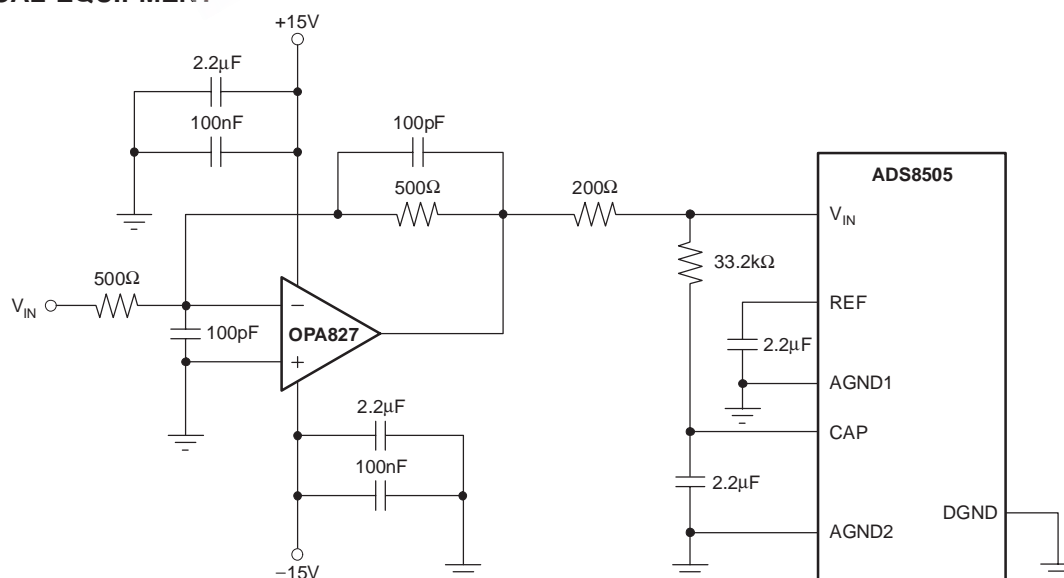

Please be aware that an important notice concerning availability, standard warranty, and use in critical applications of Texas Instruments semiconductor products and disclaimers thereto appears at the end of this data sheet.

All trademarks are the property of their respective owners.

ABSOLUTE MAXIMUM RATINGS(1)

Supply Voltage	±20V
Signal Input Terminals, Voltage(2)	(V-)–0.7 to (V+)+0.7V
Current(2)	±10mA
Differential Input Voltage	TBD V
Output Short-Circuit(3)	Continuous
Operating Temperature	–55°C to +125°C
Storage Temperature	–65°C to +150°C
Junction Temperature	+150°C



This integrated circuit can be damaged by ESD. Texas Instruments recommends that all integrated circuits be handled with appropriate precautions. Failure to observe proper handling and installation procedures can cause damage.

ESD damage can range from subtle performance degradation to complete device failure. Precision integrated circuits may be more susceptible to damage because very small parametric changes could cause the device not to meet its published specifications.

- (1) Stresses above these ratings may cause permanent damage. Exposure to absolute maximum conditions for extended periods may degrade device reliability. These are stress ratings only, and functional operation of the device at these or any other conditions beyond those specified is not supported.
- (2) Input terminals are diode-clamped to the power-supply rails. Input signals that can swing more than 0.7V beyond the supply rails should be current-limited to 10mA or less.
- (3) Short-circuit to ground, one amplifier per package.

PACKAGE/ORDERING INFORMATION(1)

PRODUCT	PACKAGE-LEAD	PACKAGE DESIGNATOR	PACKAGE MARKING
Low Grade			
OPA827A	SO-8	D	OPA827A
	MSOP-8	DGK	TBD
OPA2827A	SO-8	D	OPA2827A
	TSSOP-8	PW	TBD
High Grade			
OPA827I	SO-8	D	OPA827
	MSOP-8	DGK	TBD
OPA2827I	SO-8	D	OPA2827
	TSSOP-8	PW	TBD

(1) For the most current package and ordering information see the Package Option Addendum at the end of this document, or see the TI web site at www.ti.com.

PRODUCT PREVIEW

PIN CONFIGURATIONS

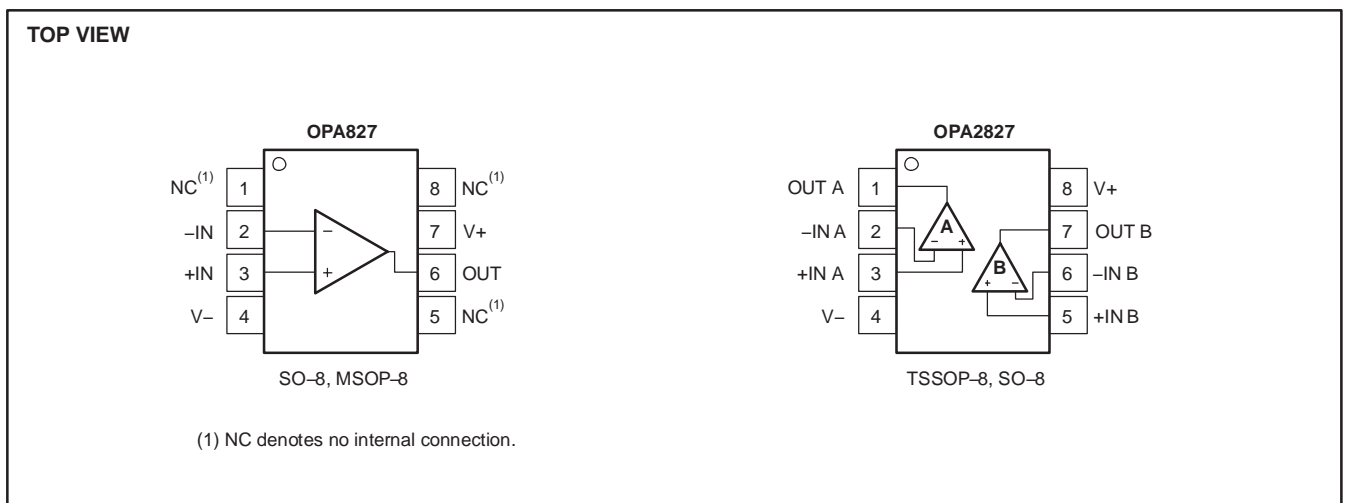

ELECTRICAL CHARACTERISTICS: $V_S = \pm 4V$ to $\pm 18V$

BOLDFACE limits apply over the specified temperature range, $T_A = -40^\circ C$ to $+125^\circ C$.

At $T_A = +25^\circ C$, $R_L = 10k\Omega$ connected to $V_S/2$, and $V_{OUT} = V_S/2$, unless otherwise noted.

PARAMETER	CONDITIONS	OPA827A, OPA2827A			OPA827I, OPA2827I			UNIT
		MIN	TYP	MAX	MIN	TYP	MAX	
OFFSET VOLTAGE								
Input Offset Voltage	V_{OS} $V_{CM} = 0V, V_S = \pm 15V$		TBD	250		TBD	TBD	μV
Drift	dV_{OS}/dT		1	3.5		TBD	TBD	$\mu V/^\circ C$
vs Power Supply	PSRR $V_S = \pm 4V$ to $\pm 18V, V_{CM} = 0V$		TBD	10		TBD	TBD	$\mu V/V$
Over Temperature	$V_S = \pm 4V$ to $\pm 18V, V_{CM} = 0V$			30			TBD	$\mu V/V$
Channel Separation, dc			TBD			TBD		$\mu V/V$
INPUT BIAS CURRENT								
Input Bias Current	I_B		± 3	TBD		*	TBD	μA
Over Temperature			TBD	TBD		TBD	TBD	μA
Input Offset Current	I_{OS}		± 3	TBD		*	TBD	μA
NOISE								
Input Voltage Noise f=0.1 to 10Hz	e_n $V_S = \pm 18V, V_{CM} = 0V$			0.4		*		μV_{PP}
Input Voltage Noise Density						*		
f = 1kHz	e_n $V_S = \pm 18V, V_{CM} = 0V$			4.5		*		nV/\sqrt{Hz}
f = 10kHz	e_n $V_S = \pm 18V, V_{CM} = 0V$			4.5		*		nV/\sqrt{Hz}
Input Current Noise Density						*		
f = 1kHz	i_n $V_S = \pm 18V, V_{CM} = 0V$			TBD		*		fA/\sqrt{Hz}
INPUT VOLTAGE RANGE								
Common-Mode Voltage Range	V_{CM} $(V-)+2.5V < V_{CM} < (V+)-2.5V$	$(V-)+2.5$		$(V+)-2.5$	*		*	V
Common-Mode Rejection Ratio	CMRR	108			TBD			dB
Over Temperature				TBD		TBD		dB
INPUT IMPEDANCE								
Differential				$10^{13} \parallel TBD$		*		$\Omega \parallel \mu F$
Common-Mode				$10^{13} \parallel 7$		*		$\Omega \parallel \mu F$
OPEN-LOOP GAIN								
Open-Loop Voltage Gain	A_{OL} $R_L = 1k\Omega$ $(V-)+2.75V < V_O < (V+)-2.1V$	114		120		TBD	TBD	dB
Over Temperature	$R_L = 1k\Omega$ $(V-)+2.75V < V_O < (V+)-2.1V$	108		TBD		TBD	TBD	dB
FREQUENCY RESPONSE								
Gain-Bandwidth Product	GBW $C_L = 100pF$			18		*		MHz
Slew Rate	SR G = +1			22		*		V/ μs
Settling Time, 0.1%	t_S 4V Step, G = +1			TBD		*		ns
0.01% (16-bit)	4V Step, G = +1			TBD		*		ns
Overload Recovery Time	$V_{IN} \bullet Gain > V_S$			TBD		*		μs
Total Harmonic Distortion + Noise	THD+N G = +1, f = 1kHz			TBD		*		%
OUTPUT								
Voltage Output Swing from Rail	$R_L = 1k\Omega, A_{OL} > 114dB$	$(V-)+2.75$		$(V+)-2.1$	*		*	V
Over Temperature	$R_L = 1k\Omega, A_{OL} > 108dB$	$(V-)+2.75$		$(V+)-2.1$	*		*	V
Output Current	I_{OUT} $ V_S - V_{OUT} < 1.5V$			30		*		mA
Short-Circuit Current	I_{SC}			± 40		*		mA
Capacitive Load Drive	C_{LOAD}			TBD		TBD		pF

NOTE: * indicates same specifications as for low-grade version of device.

ELECTRICAL CHARACTERISTICS: $V_S = \pm 4V$ to $\pm 18V$ (continued)

BOLDFACE limits apply over the specified temperature range, $T_A = -40^\circ C$ to $+125^\circ C$.

At $T_A = +25^\circ C$, $R_L = 10k\Omega$ connected to $V_S/2$, and $V_{OUT} = V_S/2$, unless otherwise noted.

PARAMETER	CONDITIONS	OPA827A, OPA2827A			OPA827I, OPA2827I			UNIT
		MIN	TYP	MAX	MIN	TYP	MAX	
POWER SUPPLY								
Specified Voltage	V_S	± 4		± 18	*		*	V
Quiescent Current (per amp.)	I_Q		4.5	TBD		*	*	mA
Over Temperature				TBD			*	mA
TEMPERATURE RANGE								
Specified Range		-40		+125	*		*	$^\circ C$
Operating Range		-55		+125	*		*	$^\circ C$
Thermal Resistance	θ_{JA}							
SO-8, MSOP-8, TSSOP-8			150			*		$^\circ C/W$

NOTE: * indicates same specifications as for low-grade version of device.



PACKAGING INFORMATION

Orderable Device	Status ⁽¹⁾	Package Type	Package Drawing	Pins	Package Qty	Eco Plan ⁽²⁾	Lead/Ball Finish	MSL Peak Temp ⁽³⁾
OPA827AID	PREVIEW	SOIC	D	8	75	TBD	Call TI	Call TI
POPA827AID	PREVIEW	SOIC	D	8	1500	TBD	Call TI	Call TI

⁽¹⁾ The marketing status values are defined as follows:

ACTIVE: Product device recommended for new designs.

LIFEBUY: TI has announced that the device will be discontinued, and a lifetime-buy period is in effect.

NRND: Not recommended for new designs. Device is in production to support existing customers, but TI does not recommend using this part in a new design.

PREVIEW: Device has been announced but is not in production. Samples may or may not be available.

OBSOLETE: TI has discontinued the production of the device.

⁽²⁾ Eco Plan - The planned eco-friendly classification: Pb-Free (RoHS), Pb-Free (RoHS Exempt), or Green (RoHS & no Sb/Br) - please check <http://www.ti.com/productcontent> for the latest availability information and additional product content details.

TBD: The Pb-Free/Green conversion plan has not been defined.

Pb-Free (RoHS): TI's terms "Lead-Free" or "Pb-Free" mean semiconductor products that are compatible with the current RoHS requirements for all 6 substances, including the requirement that lead not exceed 0.1% by weight in homogeneous materials. Where designed to be soldered at high temperatures, TI Pb-Free products are suitable for use in specified lead-free processes.

Pb-Free (RoHS Exempt): This component has a RoHS exemption for either 1) lead-based flip-chip solder bumps used between the die and package, or 2) lead-based die adhesive used between the die and leadframe. The component is otherwise considered Pb-Free (RoHS compatible) as defined above.

Green (RoHS & no Sb/Br): TI defines "Green" to mean Pb-Free (RoHS compatible), and free of Bromine (Br) and Antimony (Sb) based flame retardants (Br or Sb do not exceed 0.1% by weight in homogeneous material)

⁽³⁾ MSL, Peak Temp. -- The Moisture Sensitivity Level rating according to the JEDEC industry standard classifications, and peak solder temperature.

Important Information and Disclaimer: The information provided on this page represents TI's knowledge and belief as of the date that it is provided. TI bases its knowledge and belief on information provided by third parties, and makes no representation or warranty as to the accuracy of such information. Efforts are underway to better integrate information from third parties. TI has taken and continues to take reasonable steps to provide representative and accurate information but may not have conducted destructive testing or chemical analysis on incoming materials and chemicals. TI and TI suppliers consider certain information to be proprietary, and thus CAS numbers and other limited information may not be available for release.

In no event shall TI's liability arising out of such information exceed the total purchase price of the TI part(s) at issue in this document sold by TI to Customer on an annual basis.

MECHANICAL DATA

D (R-PDSO-G8)

PLASTIC SMALL-OUTLINE PACKAGE

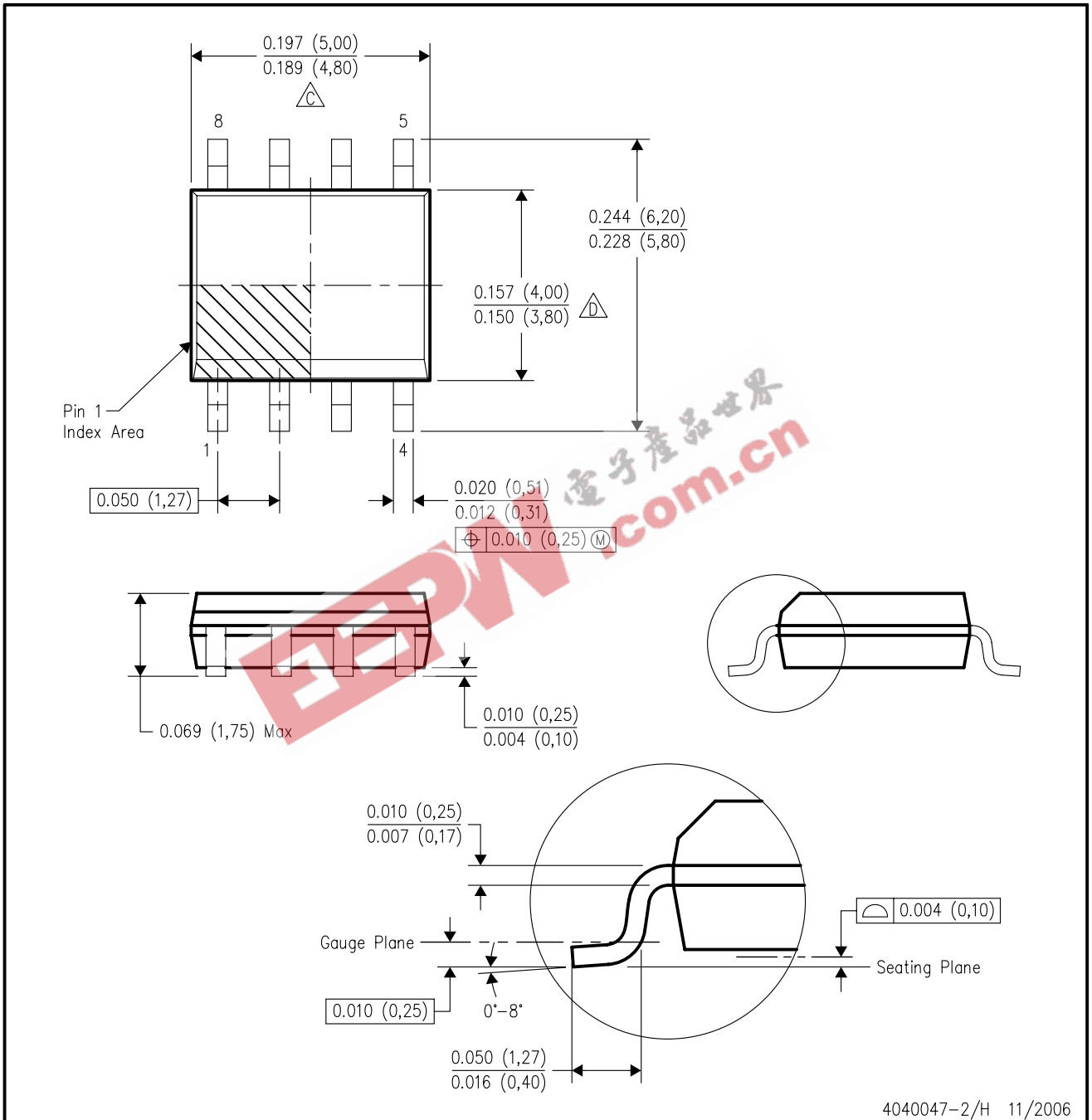

4040047-2/H 11/2006

- NOTES:
- All linear dimensions are in inches (millimeters).
 - This drawing is subject to change without notice.
 - Body length does not include mold flash, protrusions, or gate burrs. Mold flash, protrusions, or gate burrs shall not exceed .006 (0,15) per end.
 - Body width does not include interlead flash. Interlead flash shall not exceed .017 (0,43) per side.
 - Reference JEDEC MS-012 variation AA.

IMPORTANT NOTICE

Texas Instruments Incorporated and its subsidiaries (TI) reserve the right to make corrections, modifications, enhancements, improvements, and other changes to its products and services at any time and to discontinue any product or service without notice. Customers should obtain the latest relevant information before placing orders and should verify that such information is current and complete. All products are sold subject to TI's terms and conditions of sale supplied at the time of order acknowledgment.

TI warrants performance of its hardware products to the specifications applicable at the time of sale in accordance with TI's standard warranty. Testing and other quality control techniques are used to the extent TI deems necessary to support this warranty. Except where mandated by government requirements, testing of all parameters of each product is not necessarily performed.

TI assumes no liability for applications assistance or customer product design. Customers are responsible for their products and applications using TI components. To minimize the risks associated with customer products and applications, customers should provide adequate design and operating safeguards.

TI does not warrant or represent that any license, either express or implied, is granted under any TI patent right, copyright, mask work right, or other TI intellectual property right relating to any combination, machine, or process in which TI products or services are used. Information published by TI regarding third-party products or services does not constitute a license from TI to use such products or services or a warranty or endorsement thereof. Use of such information may require a license from a third party under the patents or other intellectual property of the third party, or a license from TI under the patents or other intellectual property of TI.

Reproduction of information in TI data books or data sheets is permissible only if reproduction is without alteration and is accompanied by all associated warranties, conditions, limitations, and notices. Reproduction of this information with alteration is an unfair and deceptive business practice. TI is not responsible or liable for such altered documentation.

Resale of TI products or services with statements different from or beyond the parameters stated by TI for that product or service voids all express and any implied warranties for the associated TI product or service and is an unfair and deceptive business practice. TI is not responsible or liable for any such statements.

Following are URLs where you can obtain information on other Texas Instruments products and application solutions:

Products		Applications	
Amplifiers	amplifier.ti.com	Audio	www.ti.com/audio
Data Converters	dataconverter.ti.com	Automotive	www.ti.com/automotive
DSP	dsp.ti.com	Broadband	www.ti.com/broadband
Interface	interface.ti.com	Digital Control	www.ti.com/digitalcontrol
Logic	logic.ti.com	Military	www.ti.com/military
Power Mgmt	power.ti.com	Optical Networking	www.ti.com/opticalnetwork
Microcontrollers	microcontroller.ti.com	Security	www.ti.com/security
Low Power Wireless	www.ti.com/lpw	Telephony	www.ti.com/telephony
		Video & Imaging	www.ti.com/video
		Wireless	www.ti.com/wireless

Mailing Address: Texas Instruments
Post Office Box 655303 Dallas, Texas 75265