

Fiber Optic GaAlAs High Speed LED in ST* Receptacle Types OPF347A, OPF347B, OPF347C, OPF347D

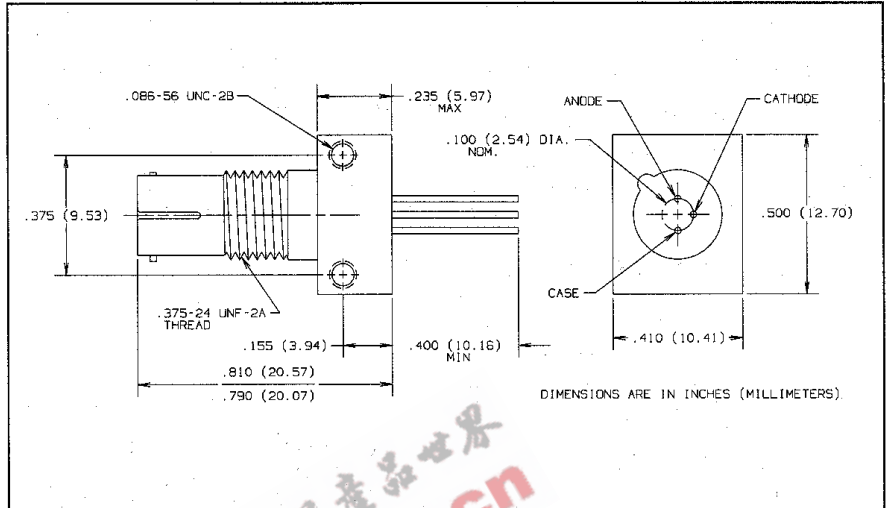
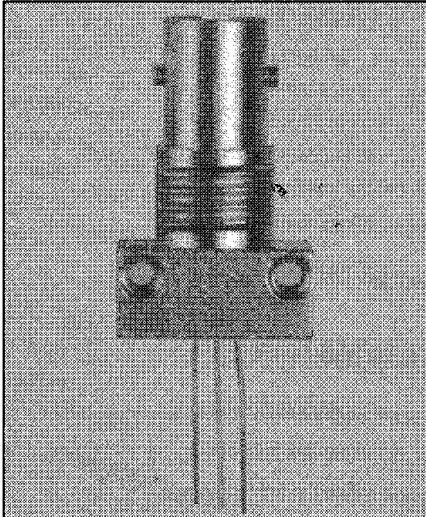

Features

- Component pre-mounted and ready to use
- Pre-tested with fiber to assure performance
- Popular ST style receptacle
- High Speed
- Electrically isolated from case

Description

The OPF347 series LED consists of a hermetic LED, pre-mounted and aligned in an ST receptacle. This configuration is designed for PC board or panel mounting. Includes lock washer and jam nut, two 2-56 screws, and a dust cap.

The LED's are designed to interface with multimode optical fibers from 50/125 to 200/300 microns.

*ST is a registered trademark of AT&T.

Absolute Maximum Ratings ($T_A = 25^\circ\text{C}$ unless otherwise noted)

Reverse Voltage	1.0 V
Continuous Forward Current	100 mA ⁽⁴⁾
Storage Temperature Range	-55° C to +150° C
Operating Temperature Range	-40° C to +125° C
Lead Soldering Temperature [1/16 inch (1.6 mm) from case for 5 sec. with soldering iron]	240° C ⁽¹⁾

Notes:

- (1) RMA flux is recommended. Duration can be extended to 10 sec. max when flow soldering.
- (2) Graded index fiber, 50 μm core, N.A. = 0.20.
- (3) To convert radiant power output to dBm, use the following expression $\text{dBm} = 10 \log (\mu\text{W}/1000)$.
- (4) Derate linearly @ 1.0 mA/°C above 25° C.
- (5) Prebias @ 5 mA current.

LED Burn-in

All LED's are subject to 100% burn-in testing. Test conditions are 96 hours at 100 mA continuous current in 25° C ambient.

TYPICAL COUPLED POWER into OPTICAL FIBER

Typical Coupled Power $I_F = 100 \text{ mA} @ 25^\circ\text{C}$						
Fiber	Refractive Index	N.A.	OPF347D	OPF347C	OPF347B	OPF347A
50/125 μm	Graded	0.20	7.5 μW	12.5 μW	18 μW	25 μW
62.5/125 μm	Graded	0.28	14 μW	22 μW	34 μW	45 μW
100/140 μm	Graded	0.29	38 μW	62 μW	95 μW	125 μW
200/300 μm^*	Step	0.41	140 μW	235 μW	340 μW	475 μW

*PCS - Plastic Clad Silica

Types OPF347A, OPF347B, OPF347C, OPF347D

Electrical Characteristics ($T_A = 25^\circ\text{C}$ unless otherwise noted)

SYMBOL	PARAMETER	MIN	TYP	MAX	UNITS	TEST CONDITIONS
P _o	Radiant Power Output	OPF347D	5.0	7.5		I _F = 100 mA ⁽²⁾
		OPF347C	10.0	12.5		
		OPF347B	15.0	18.0		
		OPF347A	20.0	25.0		
V _F	Forward Voltage		1.8	2.0	V	I _F = 100 mA
λ _p	Peak Output Wavelength	830	850	870	nm	I _F = 50 mA
B	Spectral Bandwidth Between Half Power Points		35		nm	I _F = 50 mA
t _r	Output Rise Time		3.5	4.5	ns	I _F = 100 mA, 10%-90% ⁽⁵⁾
t _f	Output Fall Time		3.5	4.5	ns	I _F = 100 mA, 90%-10% ⁽⁵⁾

Typical Performance Curves

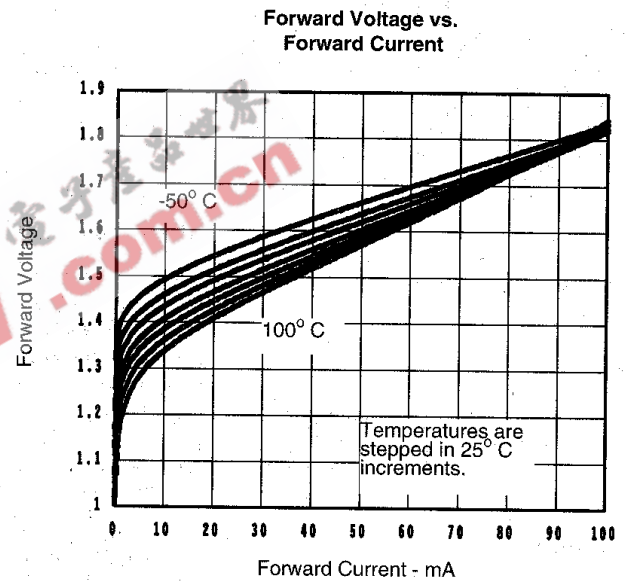
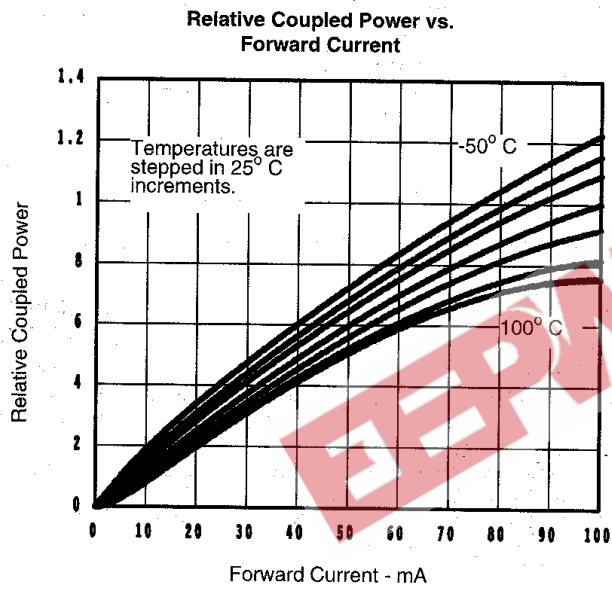

Optek reserves the right to make changes at any time in order to improve design and to supply the best product possible.

Optek Technology, Inc. 1215 W. Crosby Road Carrollton, Texas 75006 (972)323-2200 Fax (972)323-2396