

# Reflective Object Sensor Type OPB745

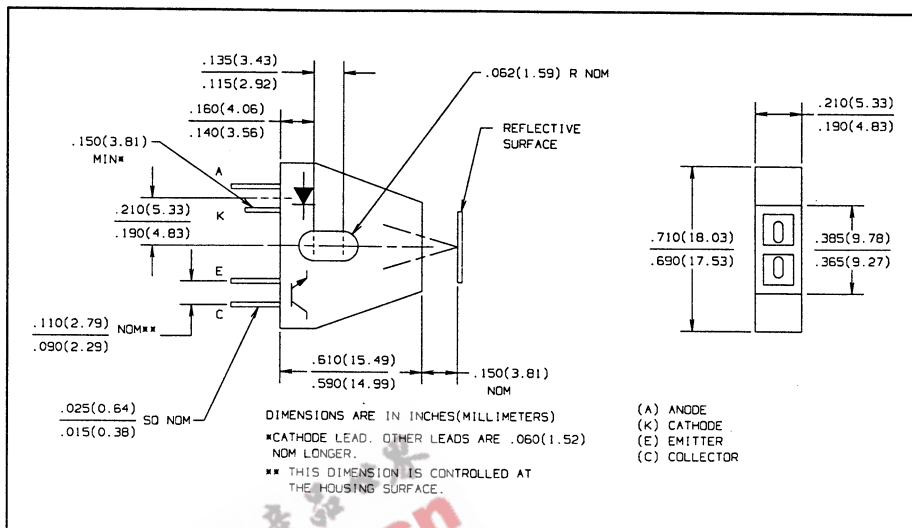
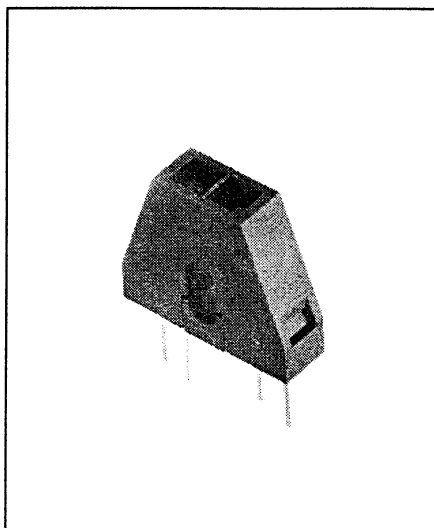

## Features

- Focused for maximum sensitivity
- Photodarlington output
- Crosstalk does not exceed specified  $I_{CEO}$
- PC board mounting

## Description

The OPB745 reflective object sensor consists of an infrared emitting diode and an NPN silicon photodarlington mounted side by side on converging optical axes in a black plastic housing.

The photodarlington responds to radiation from the emitter only when a reflective object passes within its field of view.

## Absolute Maximum Ratings ( $T_A = 25^\circ\text{C}$ unless otherwise noted)

Storage and Operating Temperature Range . . . . .  $-40^\circ\text{C}$  to  $+85^\circ\text{C}$   
Lead Soldering Temperature [1/16 inch (1.6 mm) from case for 5 sec. with soldering iron] . . . . .  $240^\circ\text{C}$ <sup>(1)</sup>

### Input Diode

Continuous Forward Current . . . . . 40 mA  
Reverse Voltage . . . . . 2.0 V  
Power Dissipation . . . . . 100 mW<sup>(2)</sup>

### Output Photodarlington

Collector-Emitter Voltage . . . . . 15 V  
Emitter-Collector Voltage . . . . . 5.0 V  
Power Dissipation . . . . . 100 mW<sup>(2)</sup>

### Notes:

- (1) RMA flux is recommended. Duration can be extended to 10 sec. max. when flow soldering.
- (2) Derate Linearly  $1.67\text{ mW}/^\circ\text{C}$  above  $25^\circ\text{C}$ .
- (3) d is distance from the assembly face to the reflective surface.
- (4) Reflective surface is Eastman Kodak neutral white test card with 90% diffuse reflectance as a reflecting surface. Reference: Eastman Kodak, Catalog #1257795.
- (5) Lower curve is based on calculated worst case condition rather than the conventional  $-2\sigma$  limit.
- (6) Crosstalk is the photocurrent measured with current to the input diode & no reflecting surface.
- (7) All parameters tested using pulse technique.

# Type OPB745

Electrical Characteristics ( $T_A = 25^\circ\text{C}$  unless otherwise noted)

SYMBOL	PARAMETER	MIN	MAX	UNITS	TEST CONDITIONS
<b>Input Diode</b>					
$V_F$	Forward Voltage		1.70	V	$I_F = 40\text{ mA}$
$I_R$	Reverse Current		100	$\mu\text{A}$	$V_R = 2.0\text{ V}$
<b>Output Photodarlington</b>					
$V_{(BR)CEO}$	Collector-Emitter Breakdown Voltage	15		V	$I_C = 100\ \mu\text{A}$
$V_{(BR)ECO}$	Emitter-Collector Breakdown Voltage	5.0		V	$I_E = 100\ \mu\text{A}$
$I_{CEO}$	Collector Dark Current		250	nA	$V_{CE} = 10\text{ V}, I_F = 0, E_e = 0$
<b>Combined</b>					
$I_{C(ON)}^{(3)(4)}$	On-State Collector Current	1.0		mA	$V_{CE} = 5\text{ V}, I_F = 40\text{ mA}, d = 0.15''$
$I_{CX}^{(2)}$	Crosstalk		250	nA	$V_{CC} = 5\text{ V}, I_F = 40\text{ mA}$

## Typical Performance Curves

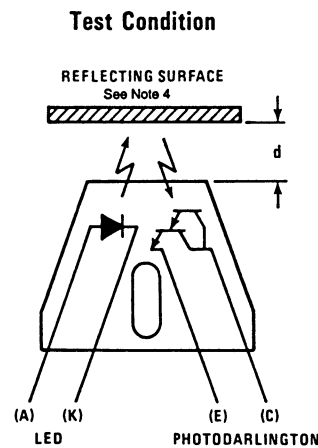
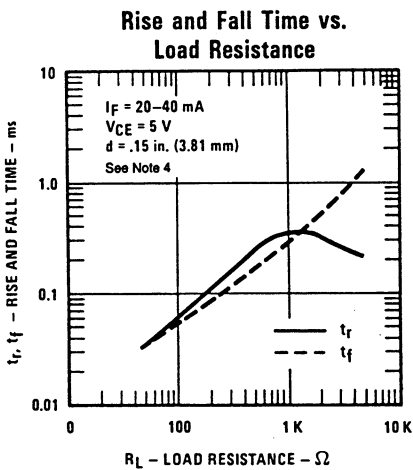
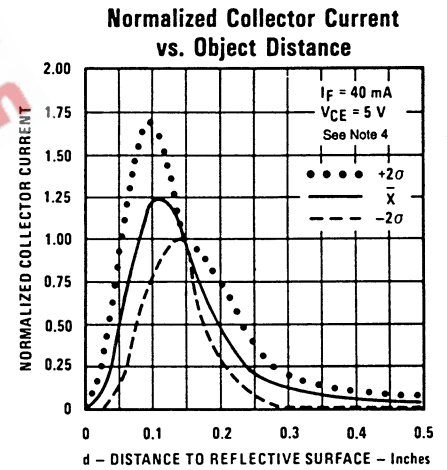
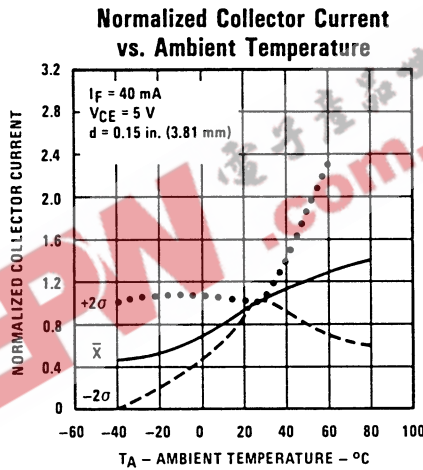
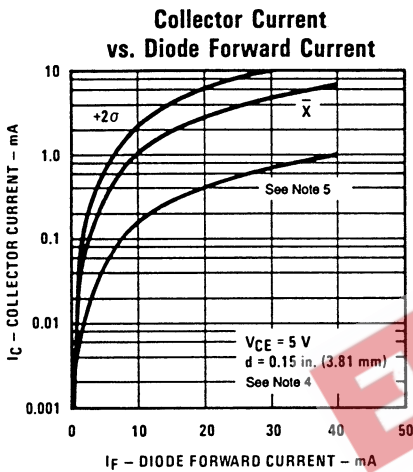

REFLECTIVE OBJECT CENTER