

Vertical Cavity Surface Emitting Laser in TO-46 Package



OPV200

Features

- 850nm VCSEL Technology
- High thermal stability
- Low drive current/high output density
- Narrow and concentric beam angle
- Up to 1.25 Gbps
- Recommended for multimode fiber applications
- Flat Window
- Burned in for communication level reliability
- Recommended for external lens applications
- Suitable for sensing applications

Description

The OPV200 is a high performance 850nm VCSEL packaged for high speed communication links. This product's combination of features including high speed, high output power and concentric beam makes it an ideal transmitter for integration into many types of data communications equipment.

Applications include:

- ◆ Fibre Channel
- ◆ Gigabit Ethernet
- ◆ ATM
- ◆ VSR (Very Short Reach)
- ◆ Intra-system links
- ◆ Optical backplane interconnects.

Technical Data

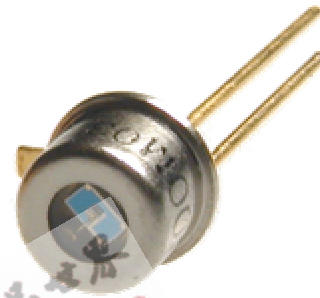

Absolute Maximum Ratings ($T_A = 25^\circ\text{C}$ unless otherwise noted)

Maximum Reverse Voltage	5 Volts
Storage Temperature	-40 to +125°C
Operating Temperature	-40 to +85°C
Soldering Lead Temperature	260°C for 10 Seconds
Max. Continuous Optical Power at 70°C	1.1 mW



Additional laser safety information can be found on the Optek website. See application #221. Classification is not marked on the device due to space limitations. See package outline for centerline of optical radiance. Operating devices beyond maximum rating may cause devices to exceed rated classification

September 2003
Issue 3.2

OPV200 Technical Data



Electrical/Optical Characteristics (at 25 °C unless otherwise specified)

SYMBOL	PARAMETER	MIN	TYP	MAX	UNITS	TEST CONDITION
P_{OT}	Power Out Total	1.45		4.5	mW	$I_F = 12 \text{ mA}$
I_{TH}	Threshold Current	2.0		5.5	mA	Note 1
V_F	Forward Voltage			2.15	V	$I_F = 12 \text{ mA}$
I_R	Reverse Current, VCSEL			30	nA	$V_R = 5 \text{ V}$
R_S	Series Resistance	15		40	ohms	Note 2
η	Slope Efficiency	0.17			mW/mA	Note 3
	Linearity	0.0				Note 4
λ	Wavelength	830	850	860	nm	
$\Delta\lambda$	Optical Bandwidth			0.85	nm	
θ	Beam Divergence		12		Degree	$I_F = 12 \text{ mA}$
t_r/t_f	Rise and Fall Time		200		ps	20% to 80%
N_{RI}	Relative Intensity Noise		-123		db/Hz	
$\Delta I_{TH}/\Delta T$	Temp Coefficient of Threshold Current		± 1.5		mA	0° - 70° C, Note 1
$\Delta\lambda/\Delta T$	Temp Coefficient of Wavelength		0.06		%/°C	0° - 70° C, $I_F = 12 \text{ mA}$
$\Delta V_F/\Delta T$	Temperature Coefficient for VF		-2.5		mV/°C	0° - 70° C, $I_F = 12 \text{ mA}$
$\Delta\eta/\Delta T$	Temperature Coefficient for Efficiency		-0.4		%/C	0° - 70° C, Note 3

NOTES:

- (1) Threshold Current is based on the two line intersection method specified in Telcordia GR-468-Core. Line 1 from 6 mA to 8 mA. Line 2 from 0 mA to 2 mA.
- (2) Series Resistance is the slope of the Voltage-Current line from 8 to 12 mA.
- (3) Slope efficiency, is the slope of the best fit LI line from 8 mA to 12 mA.
- (4) Using data points taken for slope efficiency above, $\Delta L/\Delta I$ shall be calculated for each adjacent pair of .5mA points. The minimum shall be 0.0. (No negative values permitted).

OPV200 Technical Data



Output Power vs. Forward Current

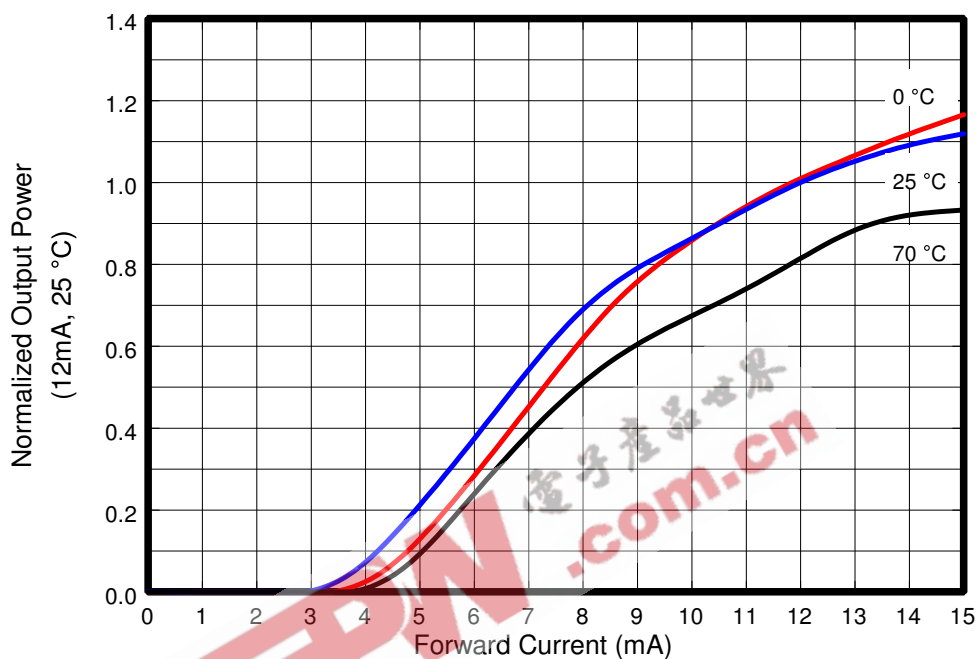

Forward Voltage vs. Forward Current

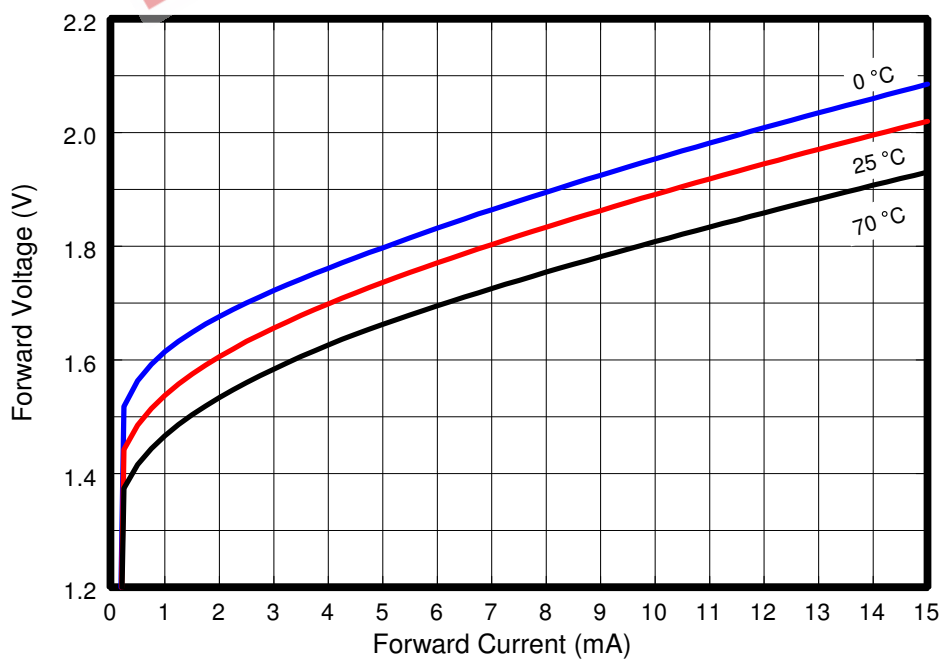

Optek reserves the right to make changes at any time in order to improve design and to supply the best product possible.

September 2003
Issue 3.2

OPV200 Technical Data

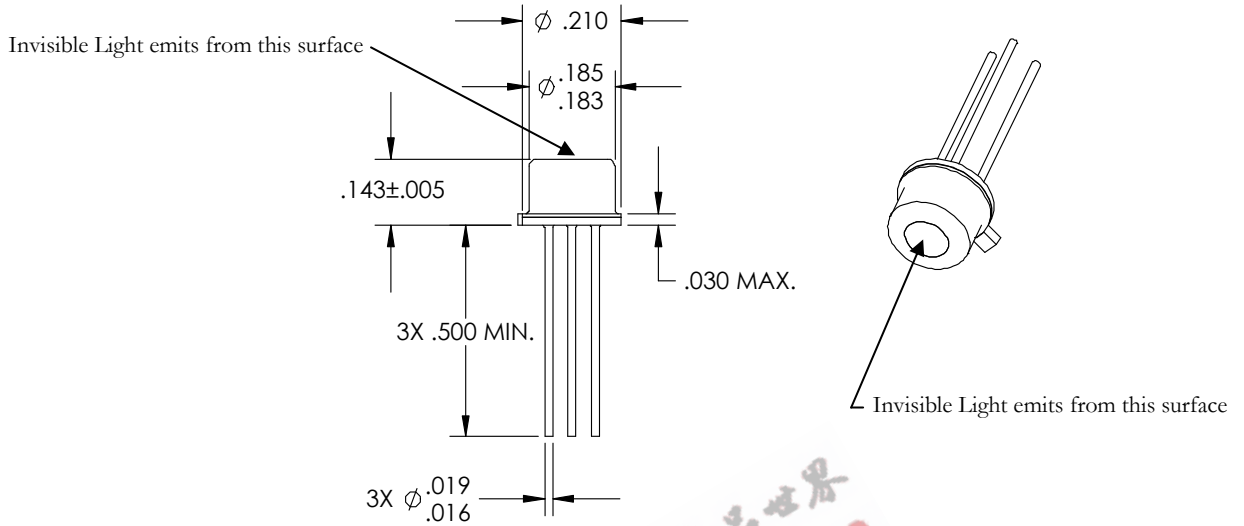

1) Tolerances are ± 0.005 unless otherwise specified

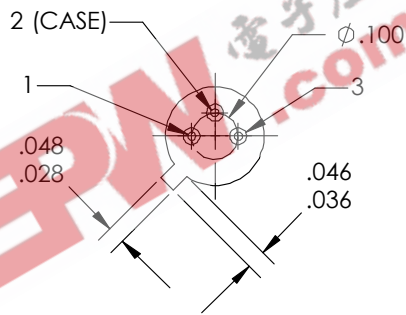

VCSEL

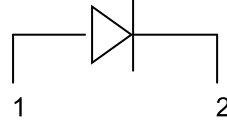

OPV200	
Pin	Connection
1	VCSEL Anode
2	VCSEL Cathode
3	N/C