

OPA643

Wideband Low Distortion, High Gain OPERATIONAL AMPLIFIER

FEATURES

- LOW DISTORTION: -90dBc at 5MHz
- LOW NOISE: $2.3\text{nV}/\sqrt{\text{Hz}}$
- GAIN-BANDWIDTH PRODUCT: 800MHz
- AVAILABLE IN SOT23-5 PACKAGE
- STABLE IN GAINS ≥ 3
- HIGH SLEW RATE: $1000\text{V}/\mu\text{s}$
- HIGH OPEN-LOOP GAIN: 95dB
- HIGH OUTPUT CURRENT: $\pm 60\text{mA}$

APPLICATIONS

- BASE STATION ADC PREAMP
- ADC/DAC BUFFER AMPLIFIER
- LOW DISTORTION IF AMPLIFIER
- LOW NOISE, BROADBAND, TRANSIMPEDANCE AMPLIFIER
- LOW NOISE PREAMPLIFIER
- VIDEO AMPLIFICATION
- TEST INSTRUMENTATION

DESCRIPTION

The OPA643 provides a level of speed and dynamic range previously unattainable in a monolithic op amp. Using a de-compensated voltage feedback architecture with two internal gain stages, the OPA643 achieves exceptionally low harmonic distortion over a wide frequency range. The "classic" differential input provides all the familiar benefits of precision op amps, such as bias current cancellation and very low inverting current noise compared with wideband current feedback op amps. High slew rate and open-loop gain, along with low input noise and high output current

drive make the OPA643 ideal for very high dynamic range requirements.

The high gain bandwidth product for the gain ≥ 3 stable OPA643 makes it particularly suitable for wideband transimpedance amplifiers and moderate gain IF amplifier applications. External compensation techniques may be used to apply the OPA643 at low gains giving exceptionally low distortion and frequency response flatness. Where unity gain stability with comparable distortion performance is required, consider the OPA642.

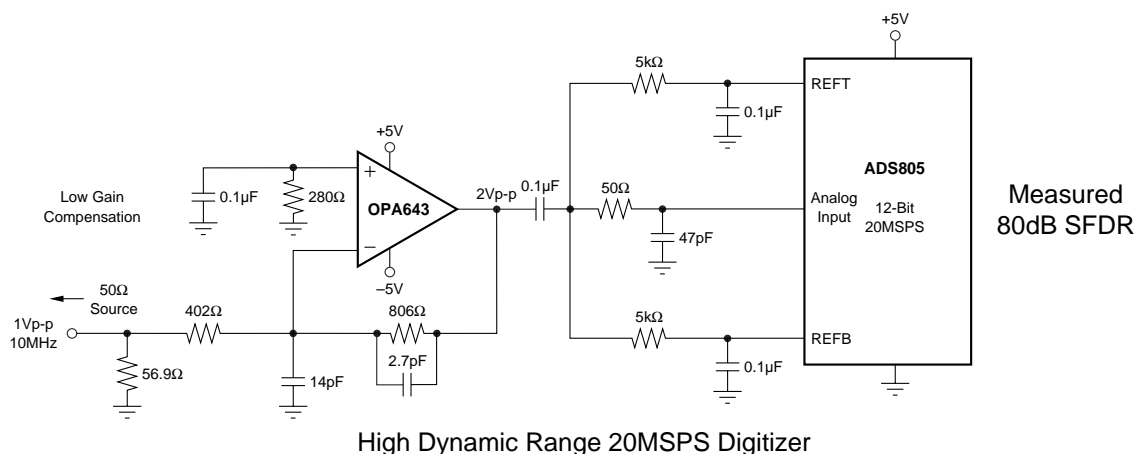

High Dynamic Range 20MSPS Digitizer

SPECIFICATIONS

ELECTRICAL

At $T_A = +25^\circ\text{C}$, $V_S = \pm 5\text{V}$, $R_L = 100\Omega$, $R_F = 402\Omega$, unless otherwise noted.

PARAMETER	CONDITIONS	OPA643P, U, N			OPA643PB, UB, NB			UNITS
		MIN	TYP	MAX	MIN	TYP	MAX	
OFFSET VOLTAGE Input Offset Voltage Average Drift Power Supply Rejection (PSR)	$V_S = \pm 4.5$ to $\pm 5.5\text{V}$	65	± 2.5 5 90	± 4	70	± 0.5 3 *	± 1.5	mV $\mu\text{V}/^\circ\text{C}$ dB
INPUT BIAS CURRENT Input Bias Current Over Specified Temperature Input Offset Current Over Specified Temperature	$V_{CM} = 0\text{V}$ $V_{CM} = 0\text{V}$		19 40 0.1	30 40 2.0 3.0		* * * *	* * * *	μA μA μA μA
NOISE Input Voltage Noise Noise Density: $f > 1\text{MHz}$ Integrated Voltage Noise, $\text{BW} = 100\text{Hz}$ to 100MHz Input Bias Current Noise Current Noise Density, $f > 1\text{MHz}$			2.3 23 2.5			* * *		$\text{nV}/\sqrt{\text{Hz}}$ μVrms $\text{pA}/\sqrt{\text{Hz}}$
INPUT VOLTAGE RANGE Common-Mode Input Range Over Specified Temperature Common-Mode Rejection (CMR)	$V_{CM} = \pm 0.5\text{V}$	± 2.75 ± 2.5 65	± 3.0 85		* * 80	* * 92		V V dB
INPUT IMPEDANCE Differential Common-Mode			7 2.5 630 1.3			* *		$\text{k}\Omega$ pF $\text{k}\Omega$ pF
OPEN-LOOP GAIN Open-Loop Voltage Gain (A_{OL}) Over Specified Temperature	$V_O = \pm 2\text{V}$, $R_L = 100\Omega$ $V_O = \pm 2\text{V}$, $R_L = 100\Omega$	82 80	95		87 80	* *		dB dB
FREQUENCY RESPONSE Closed-Loop Bandwidth Gain Bandwidth Product (GBP) Slew Rate ⁽¹⁾ At Minimum Specified Temperature Settling Time: 0.01% 0.1% 1% Spurious Free Dynamic Range (SFDR) Differential Gain Error at 3.58MHz Differential Phase Error at 3.58MHz	Gain = $+5\text{V}/\text{V}$ Gain = $+10\text{V}/\text{V}$ Gain = $+20\text{V}/\text{V}$ G = $+5$, 2V Step G = $+5$, 2V Step G = $+5$, 2V Step G = $+5$, 2V Step G = $+5$, 2V Step G = $+5$, f = 5MHz $V_O = 2\text{Vp-p}$, $R_L = 500\Omega$ G = $+5\text{V}/\text{V}$, $V_O = 0\text{V}$ to 1.4V , $R_L = 150\Omega$ G = $+5\text{V}/\text{V}$, $V_O = 0\text{V}$ to 1.4V , $R_L = 150\Omega$		200 85 40 800 1000 920 21 16.5 7.5 90 0.005 0.015			* * * * * * * * * * * * *		MHz MHz MHz MHz V/ μs V/ μs ns ns ns dBc % degrees
OUTPUT Voltage Output Over Specified Temperature Voltage Output, $+25^\circ\text{C}$ Over Specified Temperature Current Output, $+25^\circ\text{C}$ Over Specified Temperature Closed-Loop Output Resistance	No Load $R_L = 100\Omega$ 0.1MHz, G = $+5\text{V}/\text{V}$	± 3.0	± 3.25 ± 2.5 ± 40 ± 35 0.055		* * * ± 50 ± 40	* * * ± 65 *		V V V mA mA Ω
POWER SUPPLY Specified Operating Voltage Operating Voltage Range Quiescent Current Over Specified Temperature	T_{MIN} to T_{MAX}	± 4.5	± 5 ± 20	± 5.5 ± 25 ± 26	* ± 16	* * *	* * *	V V mA mA
TEMPERATURE RANGE Specification: P, U, N Thermal Resistance P, PB 8-Pin DIP U, UB 8-Pin SO-8 N, NB 5-Pin SOT23-5	Ambient θ_{JA} , Junction to Ambient	-40		+85	*	*	*	$^\circ\text{C}$ $^\circ\text{C}/\text{W}$ $^\circ\text{C}/\text{W}$ $^\circ\text{C}/\text{W}$

* Specifications same as OPA643P, U, N.

NOTE: (1) Slew rate is rate of change from 10% to 90% of output voltage step.

ABSOLUTE MAXIMUM RATINGS

Power Supply ($\pm V_S$)	± 6.0 VDC
Internal Power Dissipation ⁽¹⁾	See Thermal Analysis
Differential Input Voltage	± 1.2 V
Input Voltage Range	$\pm V_S$
Storage Temperature Range: P, PB, U, UB, N, NB	-40°C to $+125^\circ\text{C}$
Lead Temperature (soldering, 10s)	$+300^\circ\text{C}$
(soldering, SO-8 3s)	$+260^\circ\text{C}$
Junction Temperature (T_J)	$+175^\circ\text{C}$

NOTE: (1) Packages must be derated based on specified θ_{JA} . Maximum T_J must be observed.

ELECTROSTATIC DISCHARGE SENSITIVITY

Electrostatic discharge can cause damage ranging from performance degradation to complete device failure. Burr-Brown Corporation recommends that all integrated circuits be handled and stored using appropriate ESD protection methods.

ESD damage can range from subtle performance degradation to complete device failure. Precision integrated circuits may be more susceptible to damage because very small parametric changes could cause the device not to meet published specifications.

PIN CONFIGURATION

Top View

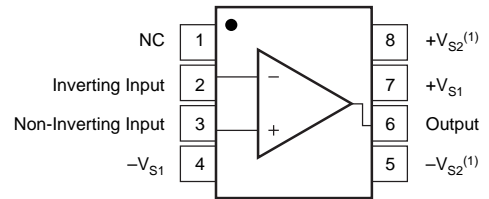

DIP/SO-8

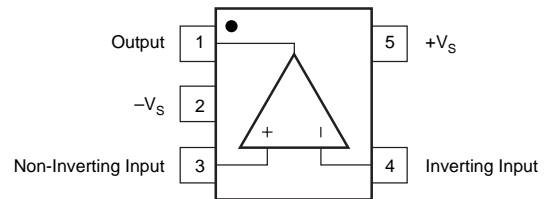

SOT23-5

NOTE: (1) Making use of all four power supply pins is highly recommended, although not required. Using these four pins, instead of just pins 4 and 7, will lower the power supply impedance improving distortion.

PACKAGE/ORDERING INFORMATION

PRODUCT	PACKAGE	PACKAGE DRAWING NUMBER ⁽¹⁾	TEMPERATURE RANGE	PACKAGE MARKING ⁽²⁾	ORDERING NUMBER ⁽³⁾
OPA643U	SO-8 Surface Mount	182	-40°C to $+85^\circ\text{C}$	OPA643U	OPA643U
OPA643UB	SO-8 Surface Mount	182	-40°C to $+85^\circ\text{C}$	OPA643UB	OPA643UB
OPA643N	5-pin SOT23-5	331	-40°C to $+85^\circ\text{C}$	A43	OPA643N-250 OPA643N-3k
OPA643NB	5-pin SOT23-5	331	-40°C to $+85^\circ\text{C}$	A43B	OPA643NB-250 OPA643NB-3k
OPA643P	8-Pin Plastic DIP	006	-40°C to $+85^\circ\text{C}$	OPA643P	OPA643P
OPA643PB	8-Pin Plastic DIP	006	-40°C to $+85^\circ\text{C}$	OPA643PB	OPA643PB

NOTES: (1) For detailed drawing and dimension table, please see end of data sheet, or Appendix C of Burr-Brown IC Data Book. (2) The "B" grade of the SO-8 and DIP packages will be marked with a "B" by pin 8. The "B" grade of the SOT23-5 will be marked with a "B" near pins 3 and 4. (3) The SOT23-5 is only available on a 7" tape and reel (e.g. ordering 250 pieces of "OPA643N-250" will get a single 250 piece tape and reel. Ordering 3000 pieces of "OPA643N-3k" will get a single 3000 piece tape and reel). Please refer to Appendix B of Burr-Brown IC Data Book for detailed Tape and Reel Mechanical information.

The information provided herein is believed to be reliable; however, BURR-BROWN assumes no responsibility for inaccuracies or omissions. BURR-BROWN assumes no responsibility for the use of this information, and all use of such information shall be entirely at the user's own risk. Prices and specifications are subject to change without notice. No patent rights or licenses to any of the circuits described herein are implied or granted to any third party. BURR-BROWN does not authorize or warrant any BURR-BROWN product for use in life support devices and/or systems.

TYPICAL PERFORMANCE CURVES

At $T_A = +25^\circ\text{C}$, $V_S = \pm 5\text{V}$, $R_L = 100\Omega$, $R_F = 402\Omega$, unless otherwise noted

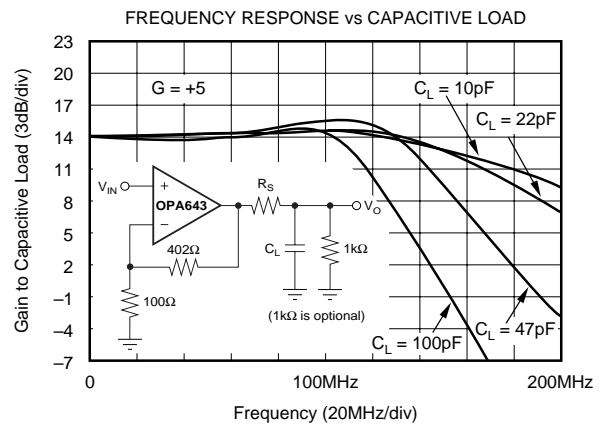
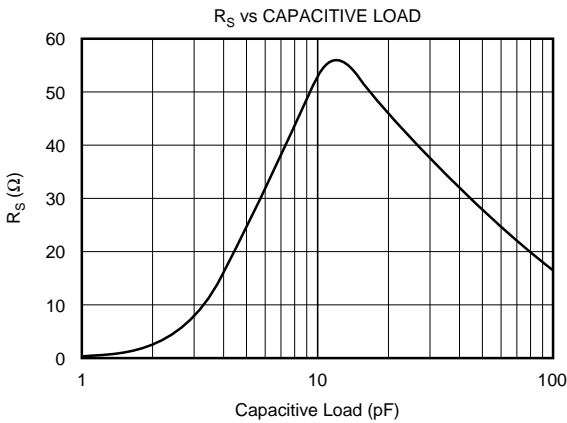
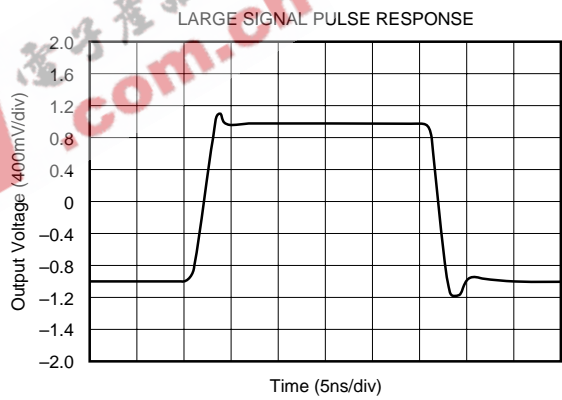
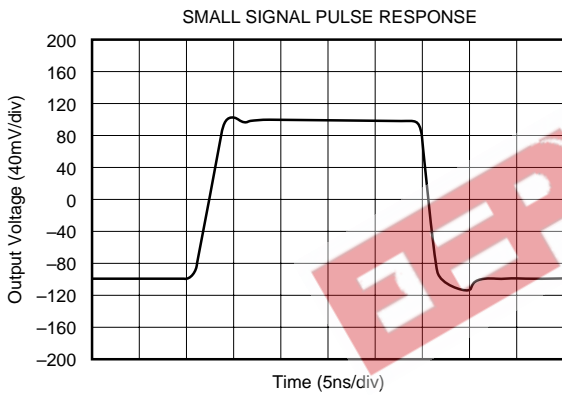
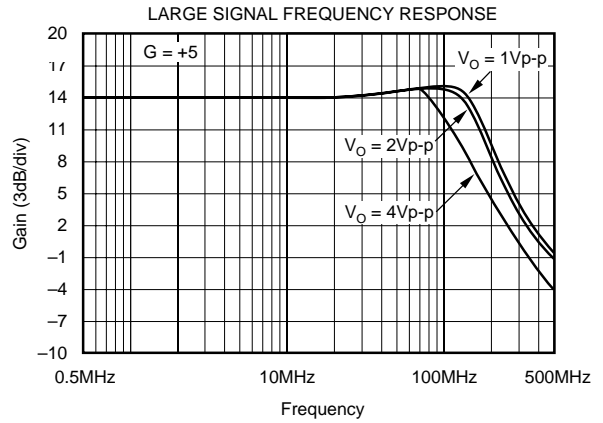
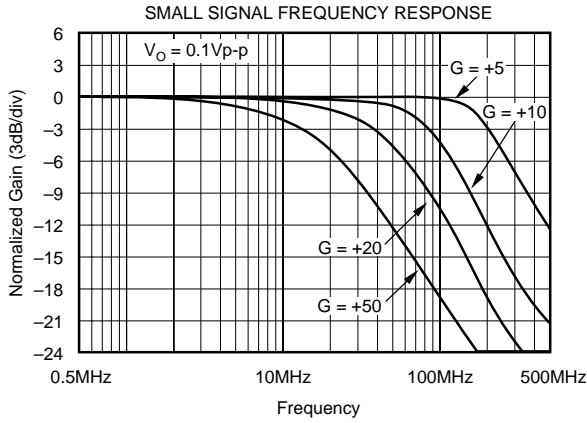

TYPICAL PERFORMANCE CURVES (CONT)

At $T_A = +25^\circ\text{C}$, $V_S = \pm 5\text{V}$, $R_L = 100\Omega$, $R_F = 402\Omega$, unless otherwise noted.

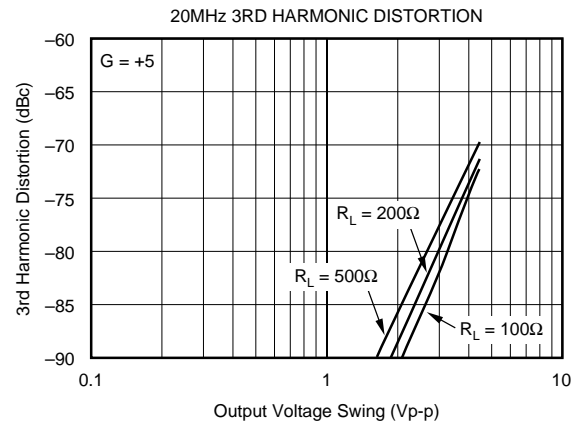
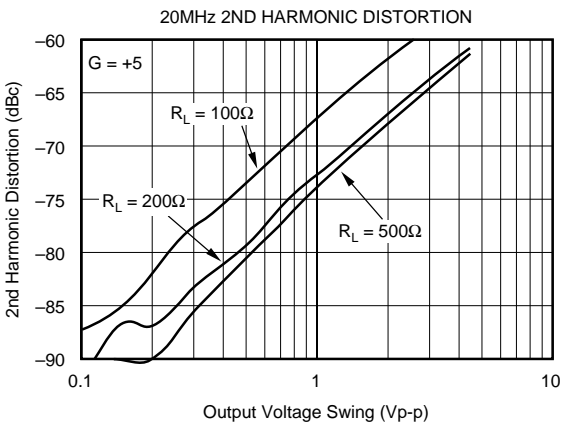
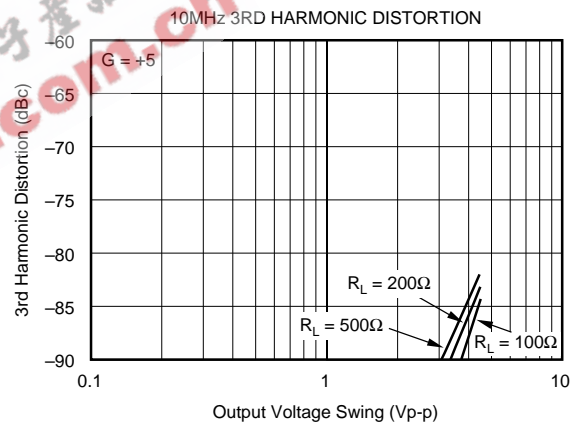
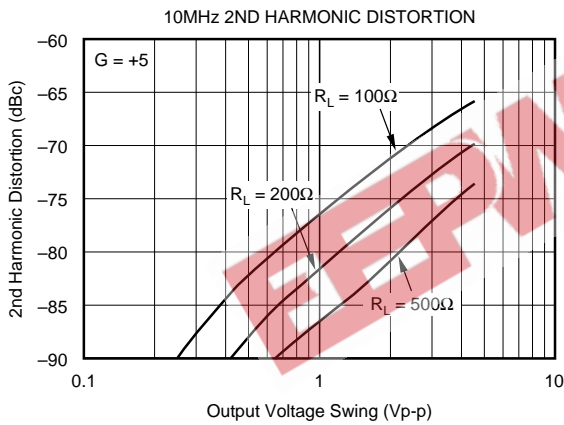
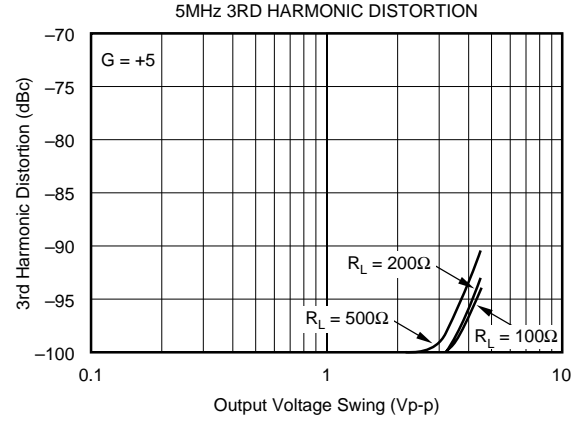
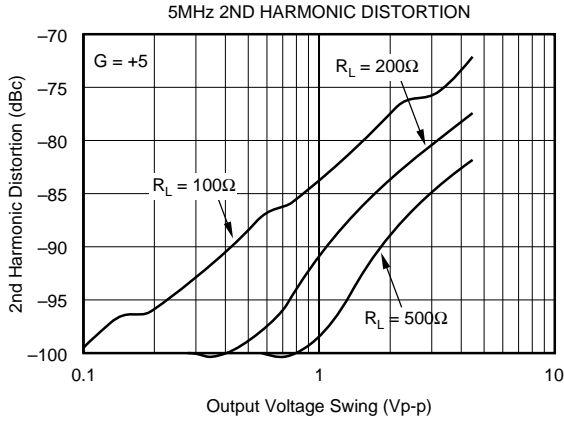

TYPICAL PERFORMANCE CURVES (CONT)

At $T_A = +25^\circ\text{C}$, $V_S = \pm 5\text{V}$, $R_L = 100\Omega$, $R_F = 402\Omega$, unless otherwise noted.

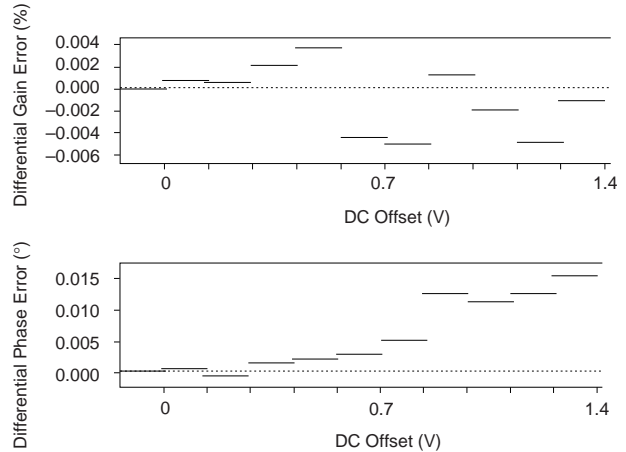
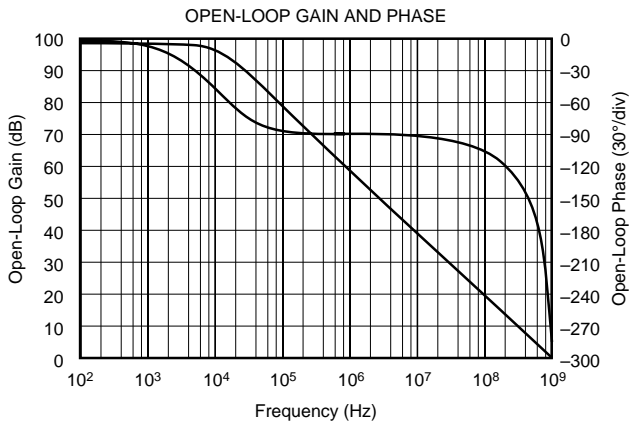
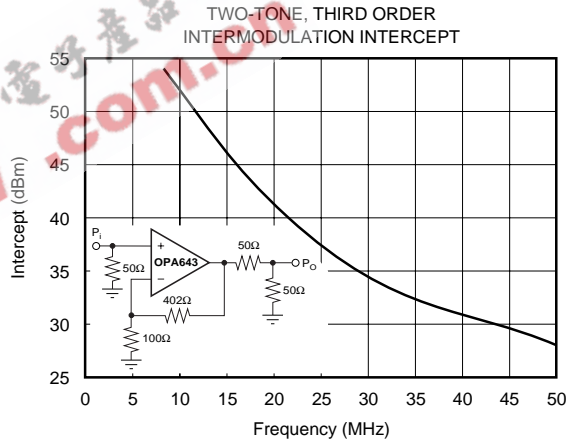
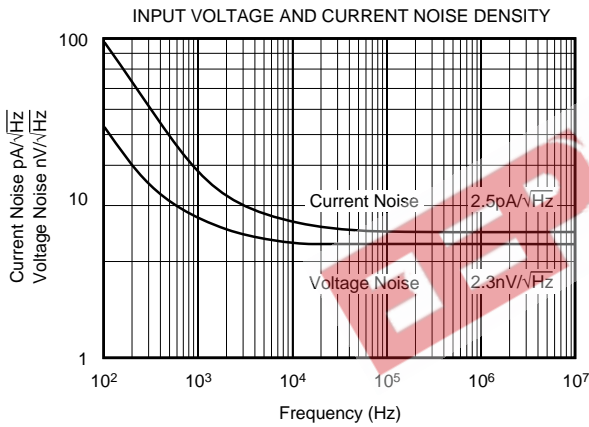
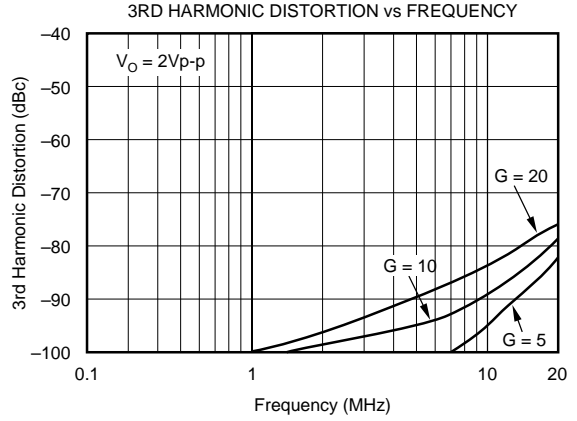
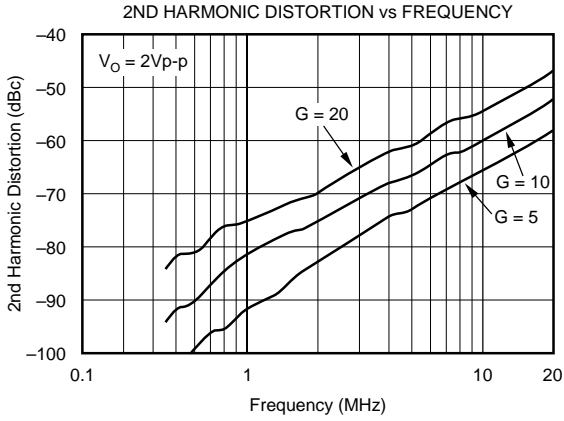

TYPICAL PERFORMANCE CURVES (CONT)

At $T_A = +25^\circ\text{C}$, $V_S = \pm 5\text{V}$, $R_L = 100\Omega$, $R_F = 402\Omega$, unless otherwise noted.

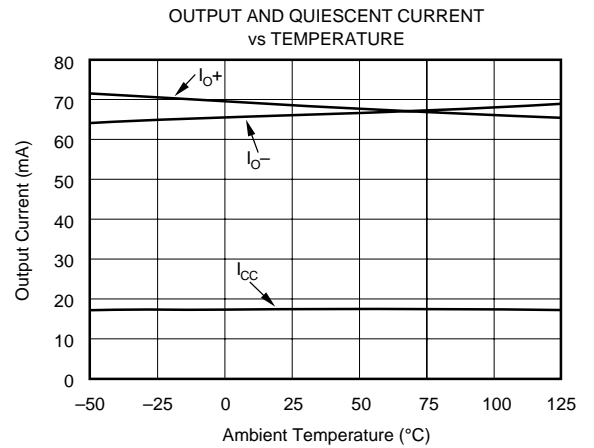
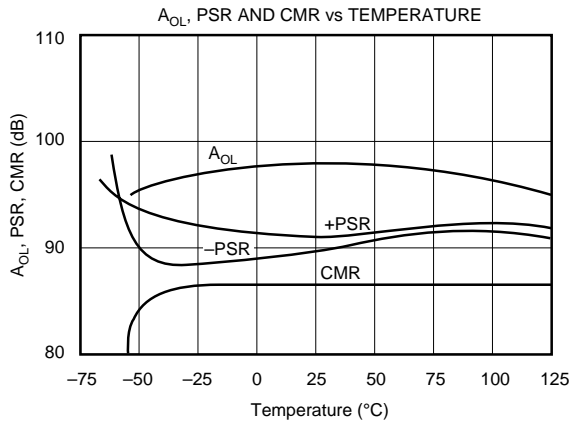
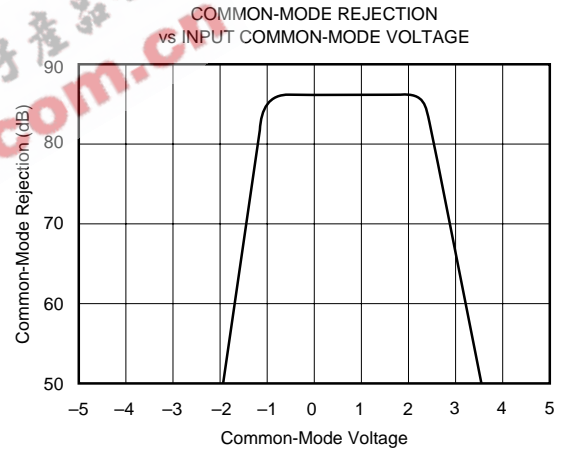
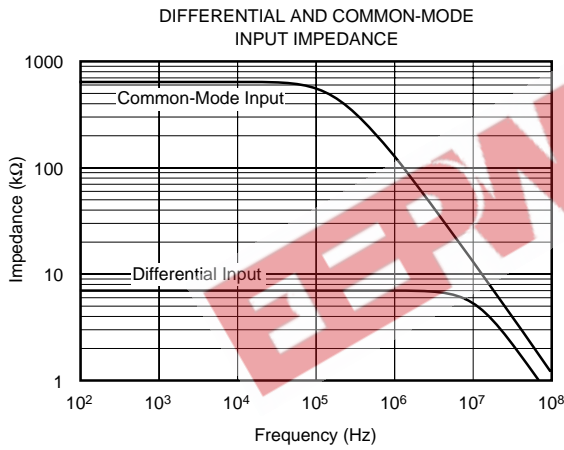
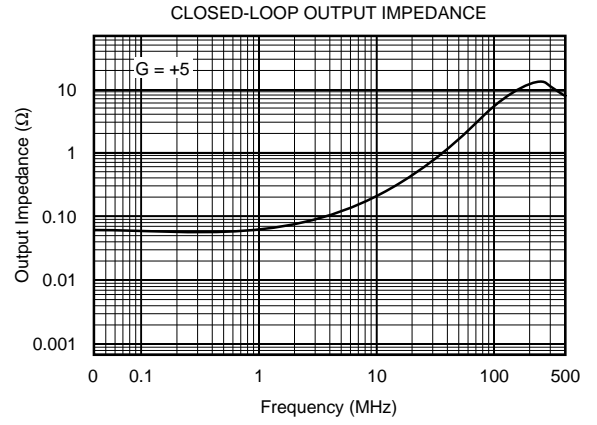
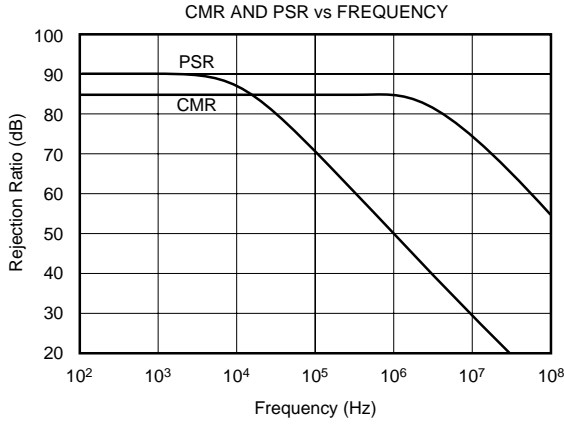

APPLICATIONS INFORMATION

TYPICAL APPLICATION AND CHARACTERIZATION CIRCUIT

The OPA643's combination of speed and dynamic range is easily achieved in a wide variety of application circuits, providing that simple guidelines common to all high speed amplifiers are observed. For example, good power supply decoupling, as shown in Figure 1, is essential to achieve the lowest possible harmonic distortion and smooth frequency response. Careful PC board layout and component selection will maximize the performance of the OPA643 in all applications, as discussed in the remaining sections of this data sheet.

Figure 1 shows the gain of +5 configuration used as the basis for most of the Typical Performance Curves. Most of the curves were characterized using signal sources with 50Ω driving impedance, and with measurement equipment presenting 50Ω load impedance. In Figure 1, the 50Ω shunt resistor at the V_I terminal matches the source impedance of the test generator, while the 50Ω series resistor at the V_O terminal provides a matching resistor for the measurement equipment load. Generally, data sheet specifications refer to the voltage swing at the output pin (V_O in Figure 1). The total 100Ω load from the series and shunt matching resistors, combined with the 502Ω total feedback network load, presents the OPA643 with an effective output load of approximately 83Ω.

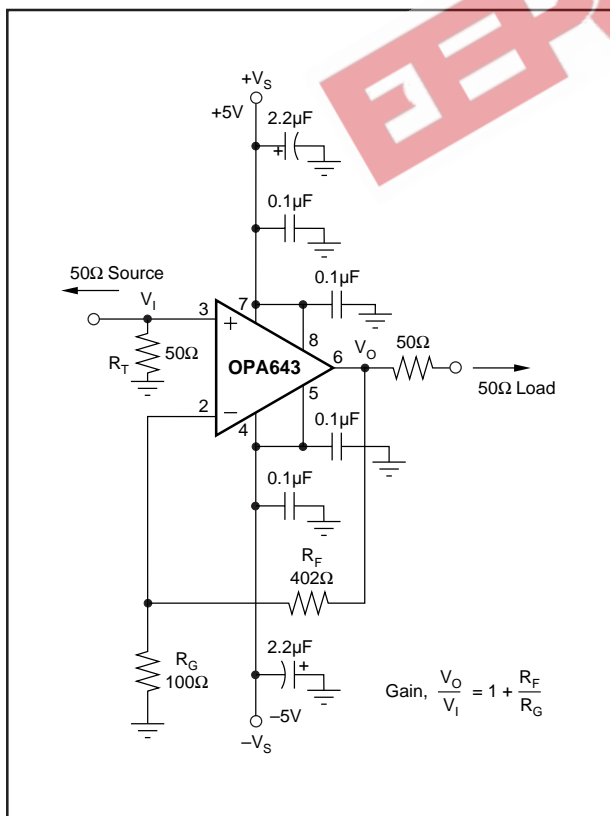

FIGURE 1. Gain of +5, High Frequency Application and Characterization Circuit (P or U Package).

BUFFERING HIGH PERFORMANCE ADC'S

To achieve full performance from a high dynamic range A/D converter, considerable care must be exercised in the design of the input amplifier interface circuit. The example circuit on the front page shows a typical AC-coupled interface to a very high dynamic range converter. This circuit uses a new external compensation technique which stabilizes the OPA643 for low signal gain, while maintaining the high gain bandwidth, fast slew rate and improved distortion performance of the decompensated architecture. Testing shows that a high loop gain and flat response are maintained through the Nyquist frequency on this circuit using the ADS805 giving very high SFDR performance. Above Nyquist, the loop gain is rolled off sharply to lower the crossover frequency, and finally additional lead is introduced at crossover to maintain good phase margin. In general, this loop gain shaping technique allows the use of high gain bandwidth, decompensated op amps to achieve better dynamic performance in low signal gain applications. Refer to the section on Low Gain Operation for further information.

The frequency domain digitizer application on the front page allows the signal swing at the output of the OPA643 to be operated at an optimum DC point. Centering the output swing between the supplies is a good starting point, but significant improvement in second-harmonic distortion can be achieved by shifting the output DC point away from ground. A typical signal swing of 2Vp-p, operating at either an optimized or a ground-centered output DC voltage, is then level shifted through the blocking capacitor to a DC reference level at the converter input. This reference voltage is created by a well decoupled resistive divider off the converter's internal reference voltages. To have negligible effect on the rated spurious-free dynamic range (SFDR) of the converter, the amplifier's SFDR should be at least 10dB greater. In the front page example, the insertion of the OPA643 has an unmeasurable effect on the distortion of the 20MSPS ADS805, which achieves 80dB SFDR at a 10MHz Nyquist input signal.

To deliver the lowest possible distortion using the 8-pin SO-8 or DIP package, additional 0.1μF power supply decoupling capacitors on pins 5 and 8 are required. These are shown in Figure 1. Although pins 5 and 8 are internally connected to pins 4 and 7 respectively (the standard supply pins for 8-pin op amps), the additional capacitors help to decouple the package lead inductances and decrease the second-harmonic distortion for a 5MHz fundamental by approximately 4dB. The much shorter bond wires and supply leads of the SOT23-5 package give the best distortion performance while requiring only two power supply connections.

Successful application to ADC buffering requires a careful selection of the series resistor at the output of the OPA643, along with the additional shunt capacitor at the ADC input. To some extent, selection of this RC network will be determined empirically for each model of converter. Many high performance CMOS ADC's, like the ADS805, perform better with an additional capacitor to ground on the input

pin. This capacitor provides a low source impedance for the transient currents produced by the sampling process. Improved SFDR is obtained by adding the capacitor, whose value is often recommended in the converter data sheet. The external capacitor, in combination with the built-in capacitance of the A/D input, presents a significant capacitive load to the OPA643. Without a series isolation resistor, the result can be peaking and possibly oscillation in the amplifier. Refer to the plot of “ R_S vs Capacitive Load” in the Typical Performance Curves to obtain a good starting value for the series resistor. The values shown in this curve will ensure a flat frequency response at the input of the ADC. Increasing the external capacitor value will allow either the series resistor to be reduced, or, keeping this resistor fixed, will bandlimit the signal and reduce high frequency noise to the input of the converter.

WIDE DYNAMIC RANGE IF AMPLIFIER

The OPA643 offers an attractive alternative to standard fixed gain IF amplifier stages. Narrowband systems will benefit from the exceptionally high two tone third-order intermodulation intercept as shown in the Typical Performance Curves. Op amps with high open-loop gain, like the OPA643, provide an intercept that decreases with frequency along with the loop gain. The OPA643's intercept is $> 25\text{dBm}$ up to 50MHz but improves to $> 50\text{dBm}$ as the operating frequency is reduced below 10MHz. Broadband systems will also benefit from the very low even order harmonics and intermodulation components produced by the OPA643. Compared to standard fixed gain IF amplifiers, the OPA643 operating at IF's below 50MHz provides much higher intercepts for its quiescent power dissipation (200mW), superior gain accuracy, higher reverse isolation, and lower I/O return loss. Noise figure for the OPA643 will be higher than alternative fixed gain stages. If the application comes late in the amplifier chain with significant gain in prior stages, this higher noise figure will be acceptable. Figure 2 shows an example non-inverting configuration for the OPA643 used as an IF amplifier.

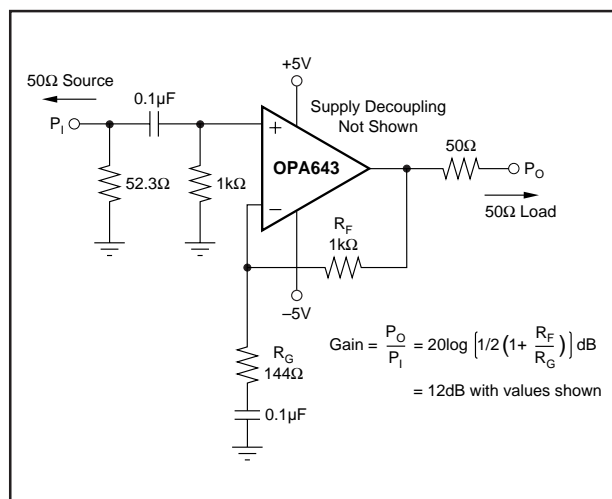

FIGURE 2. Wide Dynamic Range IF Amplifier.

The input signal and the gain resistor are AC coupled through the 0.1μF blocking capacitors. This holds the DC input and output operating point at ground independent of source impedance and gain setting. The R_G value shown in Figure 2 (144Ω) sets the gain to the matched load at 12dB. Using standard 1% tolerance resistors for R_F and R_G will hold the gain to a $\pm 0.2\text{dB}$ tolerance. This example will give a -3dB bandwidth of approximately 100MHz while maintaining gain flatness within 1dB through 50MHz. For narrowband IF's in the 21.4MHz region, this configuration of the OPA643 will show a third-order intercept of 40dBm while dissipating only 200mW (23dBm) power from $\pm 5\text{V}$ supplies.

PHOTODIODE TRANSIMPEDANCE AMPLIFIER

High Gain Bandwidth Product (GBP) and low input voltage and current noise make the OPA643 an ideal wideband transimpedance amplifier for low to moderate gains. Note that unity gain stability is not required for application as a transimpedance amplifier. Figure 3 shows an example photodiode amplifier circuit. The key parameters of this design are the estimated diode capacitance (C_D) at the applied DC reverse bias voltage ($-V_B$), the desired transimpedance gain (R_F), and the GBP for the OPA643 (800MHz). With these three variables set (and adding the OPA643's parasitic input capacitance to the value of C_D to get C_S), the feedback capacitor value (C_F) may be chosen to control the transimpedance frequency response.

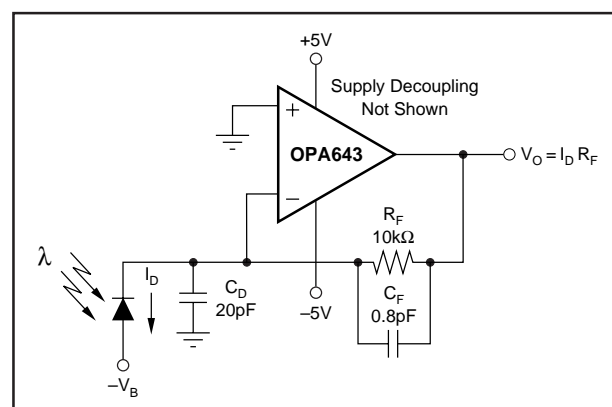

FIGURE 3. Wideband, Low Noise, Transimpedance Amplifier.

To achieve a maximally flat second-order Butterworth frequency response, the feedback pole should be set to:

$$1/(2\pi R_F C_F) = \sqrt{\text{GBP}/(4\pi R_F C_S)}$$

Adding the OPA643's common-mode and differential mode input capacitances (1.3 + 2.5)pF to the 20pF diode source capacitance of Figure 3, and targeting a 10kΩ transimpedance gain using the 800MHz GBP for the OPA643, the required feedback pole frequency is 16.4MHz. This will require a total feedback capacitance of 1.0pF. Typical surface mount resistors have a parasitic capacitance of 0.2pF, leaving the

required 0.8pF value shown in Figure 3 to get the required feedback pole.

This will set the -3dB bandwidth according to:

$$F_{-3dB} \cong \sqrt{(GBP/2\pi R_F C_S)} \text{ Hz}$$

The example of Figure 3 will give approximately 23MHz flat bandwidth using the 0.8pF feedback compensation.

WIDEBAND INVERTING SUMMING AMPLIFIER

One common application for a wideband op amp like the OPA643 is to sum a number of signal sources together. Figure 4 shows the inverting summing configuration that is most often used. This circuit offers the benefit that each input sees an input impedance set only by its individual input resistor, since the summing junction (inverting op amp node) is a virtual ground. Each input is non-interactive with every other. However, the bandwidth from any input to the summed output is set by the op amp noise gain (NG), equal to the non-inverting voltage gain. So, even though each inverting channel may have a low gain to the output (like the -1 shown in Figure 4), the overall noise gain will set the frequency response and the loop stability. The non-inverting gain for Figure 4 is equal to +5 which will give a 200MHz bandwidth at a gain of -1 for each of the input signals.

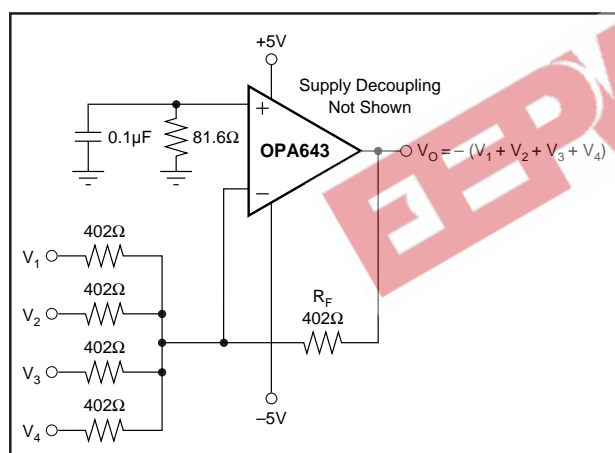

FIGURE 4. Wideband Inverting Summing Amplifier.

OPERATING SUGGESTIONS

OPTIMIZING RESISTOR VALUES

Since the OPA643 is a voltage feedback op amp, a wide range of resistor values may be used for the feedback and gain setting resistors (R_F and R_G in Figure 1). The primary limits to these values are set by dynamic range (noise and distortion) and parasitic capacitive considerations. Usually, the feedback resistor value should be between 200Ω and 1kΩ. Below 200Ω, the feedback network will present additional output loading which can degrade the harmonic distortion performance of the OPA643. Above 1kΩ, the typical parasitic capacitance (approximately 0.2pF) across the feedback resistor may cause unintentional band-limiting in the amplifier response.

A good rule of thumb is to target the parallel combination of R_F and R_G (Figure 1) to be less than about 200Ω. The combined impedance $R_F \parallel R_G$ interacts with the inverting input capacitance, placing an additional pole in the feedback network and thus a zero in the forward response. Assuming a 3pF total parasitic on the inverting node, holding $R_F \parallel R_G < 200\Omega$ will keep this pole above 250MHz. By itself, this constraint implies that the feedback resistor R_F can increase to several kΩ at high gains. This is acceptable as long as the pole formed by R_F and any parasitic capacitance appearing in parallel with it is kept out of the frequency range of interest. The exception to this is in wideband transimpedance applications as described earlier. There, a feedback pole is used to compensate for the zero formed by the input capacitance and the feedback resistor.

In the inverting configuration, an additional design constraint must be considered. R_G becomes the input resistor and therefore the load impedance to the driving source. If impedance matching is desired, R_G may be set equal to the required termination value. However, at low inverting gains, the resulting feedback resistor value can present a significant load to the amplifier output. For example, an inverting gain of -4 (noise gain of 5) with a 50Ω input matching resistor ($= R_G$) would require a 200Ω feedback resistor, which would increase output loading in parallel with the external load. To decrease the added loading, it would be preferable to increase both the R_F and R_G values, and then achieve the input matching impedance with a third resistor to ground at the input. The total input impedance becomes the parallel combination of R_G and this additional shunt input resistor.

BANDWIDTH VS GAIN

Voltage feedback op amps exhibit decreasing closed-loop bandwidth as the signal gain is increased. In theory, this relationship is described by the Gain Bandwidth Product (GBP) shown in the Electrical Specifications. Ideally, dividing GBP by the non-inverting signal gain (also called the noise gain, or NG) will predict the closed-loop bandwidth. In practice, this relationship only holds true when the phase margin approaches 90°, as it does in high gain configurations. At low signal gains, most high speed amplifiers will exhibit a more complex response with lower phase margin. The OPA643 is optimized to give a maximally flat frequency response at a gain of +5. Dividing the typical 800MHz gain bandwidth product by the noise gain of 5 would predict a closed-loop bandwidth of 160MHz. However, the actual bandwidth is extended to > 200MHz due to the reduced (< 90°) phase margin at this noise gain. Increasing the gain will increase the phase margin moving the closed-loop bandwidth closer to that predicted by the gain bandwidth product. The 40MHz bandwidth at a gain of +20, shown in the Electrical Specifications, agrees with that predicted using the 800MHz GBP.

LOW GAIN OPERATION

Decreasing the operating gain for the OPA643 from the nominal design point of +5 will decrease the phase margin.

This will increase the Q for the closed-loop poles, peaking up the frequency response and extending the bandwidth. A peaked frequency response will show overshoot and ringing in the pulse response as well as a higher integrated output noise. Operating at a noise gain less than +3 runs the risk of sustained oscillation (loop instability). However, operation at low gains would be desirable to take advantage of the much higher slew rate and lower input noise voltage available in the OPA643, as compared to performance offered by unity gain stable op amps. Numerous external compensation techniques have been suggested for operating a high gain op amp at low gains. Most of these give zero/pole pairs in the closed-loop response that cause long term settling tails in the pulse response and/or phase non-linearity in the frequency response. Figure 5 shows an external compensation method for the non-inverting configuration that does not suffer from these drawbacks.

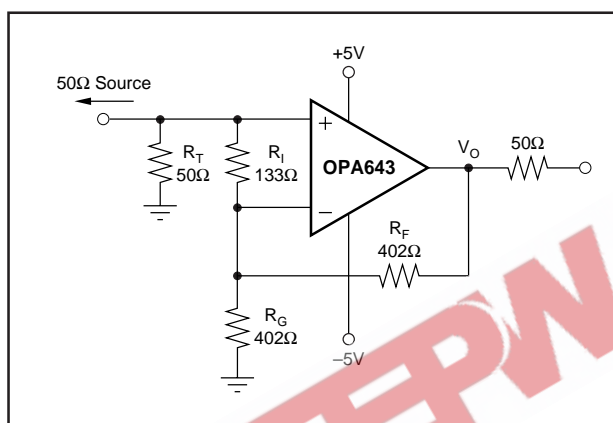

FIGURE 5. Broadband Low Gain Non-Inverting External Compensation.

The R_I resistor across the two inputs will increase the noise gain (i.e. decrease the loop gain) without changing the signal gain. This approach will retain the full slew rate to the output but will give up some of the low noise benefit of the OPA643. Assuming a low source impedance, set R_I so that $1 + R_F / (R_G \parallel R_I)$ is $\geq +3$.

Where a low gain is desired, and inverting operation is acceptable, a new external compensation technique may be used to retain the full slew rate and noise benefits of the OPA643 while maintaining the increased loop gain and the associated improvement in distortion offered by the decompensated architecture. This technique shapes the loop gain for good stability while giving an easily controlled second-order low pass frequency response. Figure 6 shows this circuit (the same amplifier circuit as shown on the front page). Considering only the noise gain for the circuit of Figure 6, the low frequency noise gain, (NG_1) will be set by the resistor ratios while the high frequency noise gain (NG_2) will be set by the capacitor ratios. The capacitor values set both the transition frequencies and the high frequency noise gain. If this noise gain, determined by $NG_2 = 1 + C_S / C_F$, is set to a value greater than the recommended minimum stable

gain for the op amp and the noise gain pole, set by $1/R_F C_F$, is placed correctly, a very well controlled second-order low pass frequency response will result.

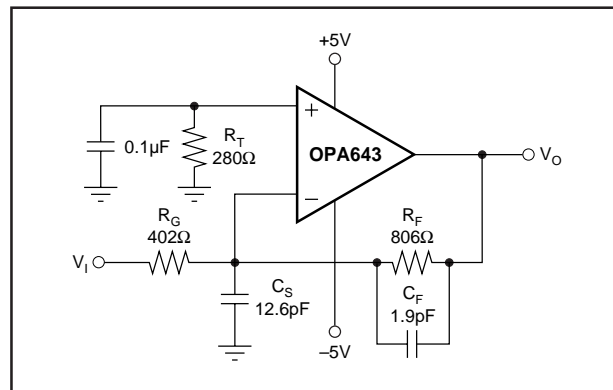

FIGURE 6. Broadband Low Gain Inverting External Compensation.

To choose the values for both C_S and C_F , two parameters and only three equations need to be solved. The first parameter is the target high frequency noise gain NG_2 , which should be greater than the minimum stable gain for the OPA643. Here, a target NG_2 of 7.5 will be used. The second parameter is the desired low frequency signal gain, which also sets the low frequency noise gain NG_1 . To simplify this discussion, we will target a maximally flat second-order low pass Butterworth frequency response ($Q = 0.707$). The signal gain of -2 shown in Figure 6 will set the low frequency noise gain to $NG_1 = 1 + R_F / R_G$ ($= 3$ in this example). Then, using only these two gains and the Gain Bandwidth Product (GBP) for the OPA643 (800MHz), the key frequency in the compensation can be determined as:

$$Z_0 = \frac{GBP}{NG_1^2} \left[\left(1 - \frac{NG_1}{NG_2} \right) - \sqrt{1 - 2 \frac{NG_1}{NG_2}} \right]$$

Physically, this Z_0 (13.6MHz for the values shown in Figure 6) is set by $1 / (2\pi \cdot R_F (C_F + C_S))$ and is the frequency at which the rising portion of the noise gain would intersect unity gain if projected back to 0dB gain. The actual zero in the noise gain occurs at $NG_1 \cdot Z_0$ and the pole in the noise gain occurs at $NG_2 \cdot Z_0$. Since GBP is expressed in Hz, multiply Z_0 by 2π and use this to get C_F by solving:

$$C_F = \frac{1}{2\pi \cdot R_F Z_0 NG_2}$$

Finally, since C_S and C_F set the high frequency noise gain, determine C_S by:

$$C_S = (NG_2 - 1) C_F$$

The resulting closed-loop bandwidth will be approximately equal to:

$$F_{-3dB} \cong \sqrt{Z_0 \text{ GBP}}$$

For the values shown in Figure 6, the F_{-3dB} will be approximately 105MHz. This is less than that predicted by simply dividing the GBP product by NG_1 . The compensation network controls the bandwidth to a lower value while providing full slew rate and exceptional distortion performance due to increased loop gain at frequencies below $NG_1 \cdot Z_0$. The capacitor values shown in Figure 6 are calculated for $NG_1 = 3$ and $NG_2 = 7.5$ with no adjustment for parasitics. These differ slightly from the application circuit on the front page, since those have been adjusted for parasitics and to account for the capacitive load (through R_S) at the ADC input.

OUTPUT VOLTAGE AND CURRENT DRIVE

The OPA643 has been optimized to drive the demanding load of a doubly terminated transmission line. When a 50Ω line is driven, a series 50Ω source resistance into the cable and a terminating 50Ω load at the end of the cable are used. Under these conditions, the cable's impedance will appear resistive over a wide frequency range, and the total effective load on the OPA643 is 100Ω in parallel with the resistance of the feedback network. The specifications show a guaranteed $\pm 2.5V$ swing over the full temperature range into this 100Ω load—which will then be reduced to a $\pm 1.25V$ swing at the termination resistor. The guaranteed $\pm 35mA$ output current over temperature provides adequate current drive margin for this load. Higher voltage swings (and lower distortion) are achievable when driving higher impedance loads.

A common IF amplifier specification which describes available output power is the $-1dB$ compression point. This is usually defined at a matched 50Ω load to be the sinusoidal power where the gain has compressed by $-1dB$ vs the gain seen at very low power levels. This compression level is frequency dependent for an op amp, due to both bandwidth and slew rate limitations. For frequencies well within the bandwidth and slew rate limit of the OPA643, the $-1dB$ compression at a matched 50Ω load will be $> 13dBm$ based on the minimum available $\pm 1.25V$ swing at the load. One common use for the $-1dB$ compression is to predict intermodulation intercept. This is normally $10dB$ greater than the $-1dB$ compression power for a standard RF amplifier. This simple rule of thumb does NOT apply to the OPA643. The high open loop gain and Class AB output stage of the OPA643 produce a much higher intercept than the $-1dB$ compression would predict, as shown in the Typical Performance Curves.

DRIVING CAPACITIVE LOADS

One of the most demanding and yet very common load conditions for an op amp is capacitive loading. A high speed, high open-loop gain amplifier, like the OPA643, can be very susceptible to decreased stability and closed-loop response peaking when a capacitive load is placed directly on the output pin. In simple terms, the capacitive load reacts with the open-loop output resistance of the amplifier to introduce an additional pole into the loop and thereby decrease the

phase margin. This issue has become a popular topic of application notes and articles, and several external solutions to this problem have been suggested. When the primary considerations are frequency response flatness, pulse response fidelity and/or distortion, the simplest and most effective solution is to isolate this capacitive load from the feedback loop by inserting a series isolation resistor between the output and the capacitive load. This does not eliminate the pole from the loop response, but rather shifts it and adds a zero at a higher frequency. The additional zero acts to cancel the phase lag from the capacitive load pole, increasing the phase margin and improving stability.

The Typical Performance Curves show the recommended series R_S vs Capacitive Load and the resulting frequency response at the load. The criterion for setting this resistor is a maximum bandwidth, flat frequency response at the load. Since there is now a passive low pass filter from the output pin to the load capacitor, the response at the output pin itself is typically somewhat peaked, and becomes flat after the rolloff action of the RC network. This is not a concern in most applications, but can cause clipping if the desired signal swing at the load is very close to the amplifier's swing limit. Such clipping would be most likely to occur for a large signal pulse response where this slight peaking causes an overshoot in the step response at the output pin.

Parasitic capacitive loads greater than $2pF$ can begin to degrade the performance of the OPA643. Long PC board traces, unmatched cables, and connections to multiple devices can easily exceed $2pF$. Always take care to consider this, and add the recommended series resistor as close as possible to the OPA643 output pin (see Board Layout Guidelines).

DISTORTION PERFORMANCE

The OPA643 is capable of delivering an exceptionally low distortion signal at high frequencies over a wide range of gains. The distortion plots in the Typical Performance Curves show the typical distortion under a wide variety of conditions. Most of these plots are limited to $100dB$ dynamic range. The OPA643's distortion does not rise above $-90dBc$ until either the signal level exceeds $0.5V$ and/or the fundamental frequency exceeds $500kHz$. **Distortion in the audio band is $< -120dBc$.**

Generally, until the fundamental signal reaches very high frequencies or powers, the second harmonic will dominate the distortion with negligible third harmonic component. Focusing then on the second harmonic, increasing the load impedance improves distortion directly. Remember that the total load includes the feedback network—in the non-inverting configuration this is sum of $R_F + R_G$, while in the inverting configuration it is only R_F (Figure 1). Larger output voltage swings lead directly to increased harmonic distortion. A $6dB$ increase in output voltage swing will generally increase the second harmonic by $12dB$ and the third harmonic by $18dB$. Higher signal gain settings will also increase the second harmonic distortion. A $6dB$ increase in voltage gain will raise the second and third harmonics by

6dB each, even at constant output power and frequency. This effect is due to the reduction in loop gain which accompanies an increase in signal gain. Finally, distortion grows as the fundamental frequency increases, due to the rolloff in loop gain with frequency. Going the other direction, distortion will improve at lower frequencies until the dominant open loop pole is reached at approximately 8kHz. Starting with the -92dBc second-harmonic for a 1MHz, 2Vp-p fundamental into a 500Ω load at $G = +5$ (from the Typical Performance Curves), the second-harmonic distortion at 20kHz will be approximately $(-92\text{dBc} - 20\log(1\text{MHz}/20\text{kHz})) \cong -126\text{dBc}$, while the third-order terms will be much lower.

In most applications the second-harmonic will set the limit to dynamic range. Even order nonlinearity arises from slight asymmetries between the positive and negative halves of the output sinusoid. This asymmetrical nonlinearity comes from such mechanisms as voltage dependent junction capacitances, transistor gain mismatches and imbalanced source impedances looking out of the amplifier power pins. Once a circuit and board layout has been determined, these asymmetries can often be nulled out by adjusting the DC operating point for the signal. An example of such DC trimming is shown in Figure 7. This circuit has a DC coupled inverting signal path to the output pin, providing gain for a small DC offset signal applied to the non-inverting input pin. The output is AC coupled to block off this DC operating point and prevent it from interacting with the following stage.

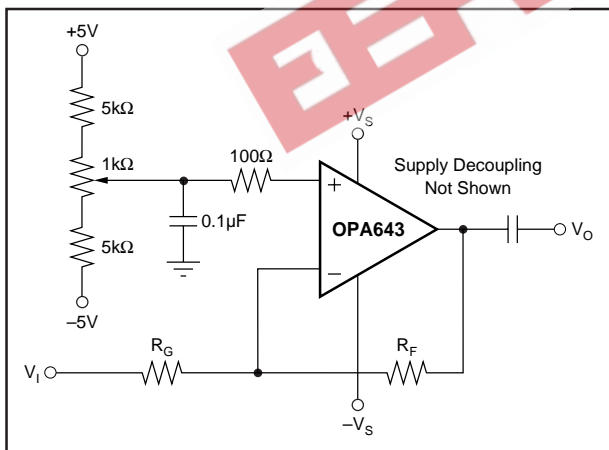

FIGURE 7. DC Adjustment for Second-Harmonic Reduction.

For a 1Vp-p output swing in the 10 to 20MHz region, an output DC voltage in the $\pm 1.5\text{V}$ range will null the second-harmonic distortion. Tests of this technique with a 200Ω converter input load have shown greater than 15dB improvement in the second-harmonic component. Once the required DC offset voltage is found for a particular board, circuit, and signal requirement, the voltage is very repeatable from part to part and may be fixed permanently at the non-inverting input. Minimal degradation in second harmonic distortion over temperature has been observed.

The OPA643 has extremely low third-order harmonic distortion. This characteristic leads to the exceptionally high 2-tone third-order intermodulation intercept as shown in the Typical Performance Curves. The intercept curve is defined at the 50Ω load when driven through a 50Ω matching resistor to allow direct comparisons to RF MMIC devices. The matching network attenuates the voltage swing from the output pin to the load by 6dB. If the OPA643 drives directly into the input of a high impedance device such as an ADC, the 6dB attenuation does not exist and the intercept will increase by at least 6dBm. The intercept is used to predict intermodulation spurs for two closely spaced input frequencies. If the two test frequencies, f_1 and f_2 , are specified in terms of average and delta frequency,

$$f_0 \equiv (f_1 + f_2)/2 \text{ and } \Delta f \equiv |f_2 - f_1|/2$$

the two third-order, close-in spurious tones will appear at $f_0 \pm (3 \cdot \Delta f)$. The difference in power between two equal test tones and the intermodulation products is given by $\Delta\text{dBc} = 2 \cdot (\text{IM3} - P_0)$ where IM3 is the intercept taken from the Typical Performance Curves and P_0 is the power level in dBm at the 50Ω load for one of the two closely spaced test frequencies. For instance, at 10MHz the OPA643 at a gain of +5 has an intercept of 52dBm at the matched 50Ω load. If the full envelope of the two frequencies is 2Vp-p, then each tone will be at 4dBm. The third-order intermodulation spurs will then be $2 \cdot (52 - 4) = 96\text{dBc}$ below the test tone power level (-92dBm). If this same 2Vp-p two-tone envelope were delivered directly into the input of an ADC without the matching loss or loading of the $50\Omega/50\Omega$ network, the intercept would increase to at least 58dBm. With the same signal and gain conditions, but now driving directly into a light load, the spurious tones will be at least $2 \cdot (58 - 4) = 108\text{dBc}$ below the 4dBm test tone power levels centered at 10MHz.

NOISE PERFORMANCE

The OPA643 complements its ultra-low harmonic distortion with low input noise terms. The input voltage noise combines with the two input current noise terms to give low output noise under a wide variety of operating conditions. Figure 8 shows the op amp noise analysis model with all noise terms included. In this model, all voltage and current noise density terms are expressed in $\text{nV}/\sqrt{\text{Hz}}$ or $\text{pA}/\sqrt{\text{Hz}}$ respectively.

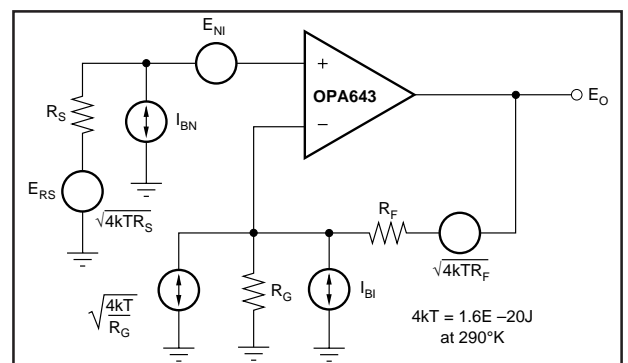

FIGURE 8. Op Amp Noise Analysis Model.

The total output noise voltage density can be computed as the square root of the sum of all squared output noise voltage contributors. Equation 1 shows the general form for the output noise voltage using the terms shown in Figure 8.

Eq. 1

$$E_O = \sqrt{\left(E_{NI}^2 + (I_{BN}R_S)^2 + 4kTR_S\right)NG^2 + \left(I_{BI}R_F\right)^2 + 4kTR_F}NG$$

Dividing this expression by the noise gain ($NG = (1+R_F/R_G)$) will give the equivalent input referred spot noise voltage at the noninverting input as shown in Equation 2.

Eq. 2

$$E_N = \sqrt{E_{NI}^2 + (I_{BN}R_S)^2 + 4kTR_S + \left(\frac{I_{BI}R_F}{NG}\right)^2 + \frac{4kTR_F}{NG}}$$

Evaluating these two equations for the OPA643 component values shown in Figure 1 will give a total output spot noise voltage of $13.3nV/\sqrt{Hz}$ and a total equivalent input spot noise voltage of $2.7nV/\sqrt{Hz}$.

Narrowband communications systems are more commonly concerned with the Noise Figure (NF) for the amplifier. The total input referred voltage noise expression (Equation 2 above), may be used to calculate the noise figure. Equation 3 shows the noise figure expression using the E_N of Equation 2 for the non-inverting configuration where the input termination resistor R_T has been set to match the 50Ω source impedance (as shown in Figure 1).

$$NF = 10 \log \left[2 + \frac{E_N^2}{kTR_S} \right] \quad \text{Eq. 3}$$

Evaluating Equation 3 for the circuit of Figure 1 gives a Noise Figure = 15.9dB. Input transformer coupling can be used to reduce this noise figure. A broadband pulse transformer can provide both a noiseless voltage gain and a more optimum source impedance to minimize the noise figure. Figure 9 shows an example built from the circuit of Figure 1, in which the transformer turns ratio has been set to the closest integer for minimum noise figure. This optimum turns ratio is calculated by:

Eq. 4

$$N_{OPT} = \text{Nearest Integer} \left(\sqrt{E_N / (I_{BN} \cdot (R_S / 2))} \right)$$

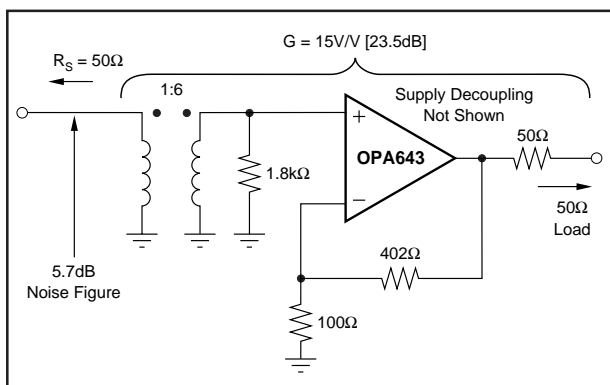

FIGURE 9. Reduced Noise Figure Circuit.

DC OFFSET CONTROL

The OPA643 provides excellent DC signal accuracy due to the combination of high open-loop gain, high common-mode rejection, high power supply rejection, low input offset voltage and low bias current offset errors. The high grade (B) version of any package type provides less than 1.5mV input offset voltage. To take full advantage of this low input offset voltage, careful attention to input bias current cancellation is also required. The high speed input stage for the OPA643 has a relatively high input bias current (19μA typical into each input pin) but with a very close match between the two input currents—typically 100nA input offset current. The total output offset voltage may be considerably reduced by matching the source resistances which appear at the two inputs. For example, one way to include bias current cancellation in the circuit of Figure 1 would be to insert a 55Ω series resistor into the non-inverting input after the 50Ω terminating resistor, R_T . When the 50Ω source resistor is DC coupled, this will increase the source resistance for the non-inverting input bias current to 80Ω . Since this is now equal to the resistance appearing at inverting input ($R_F \parallel R_G$), the circuit will cancel the gains for the bias currents to the output, leaving only the offset current times the feedback resistor as a residual DC error term at the output. Using a 402Ω feedback resistor, this output error will now be less than $3\mu A \cdot 402\Omega = 1.2mV$ over the full temperature range.

A fine scale output offset null, or DC operating point adjustment, is often required. Numerous techniques are available for introducing DC offset control into an op amp circuit. Most of these techniques eventually reduce to setting up a DC current through the feedback resistor. In selecting an offset trim method, one key consideration is the impact on the desired signal path frequency response. If the signal path is intended to be non-inverting, the offset control is best applied as an inverting summing signal to avoid interaction with the signal source. If the signal path is intended to be inverting, applying the offset control to the non-inverting input may be considered—however, the DC offset voltage on the summing junction will set up a DC current back into the source which must be considered. Applying an offset adjustment to the inverting op amp input can change the noise gain and frequency response flatness. For a DC coupled inverting amplifier, Figure 10 shows one example of an offset adjustment technique that has minimal impact on the signal frequency response. In this case, the DC offsetting current is brought into the inverting input node through a resistor which is much larger than the signal path resistors. This will insure that the adjustment circuit has minimal effect on the noise gain and hence the frequency response.

THERMAL ANALYSIS

The OPA643 will not require heatsinking under most operating conditions. Maximum desired junction temperature will set the maximum allowable internal power dissipation as described below. In no case should the maximum junction temperature be allowed to exceed $175^\circ C$.

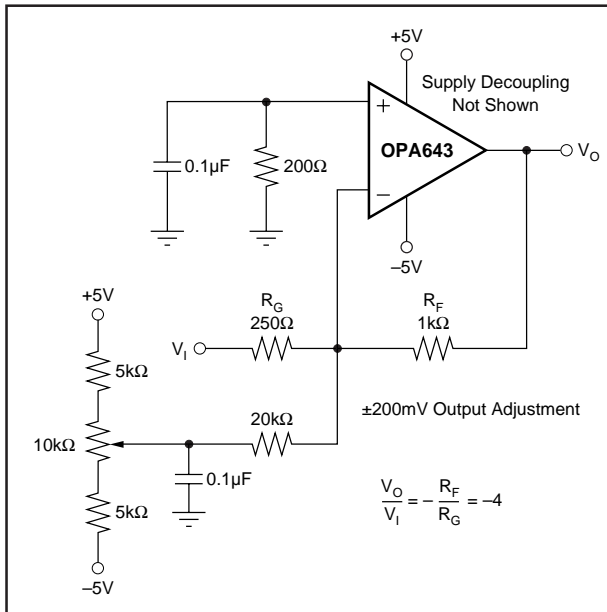

FIGURE 10. DC Coupled, Inverting Gain of -4 , with Output Offset Adjustment.

Operating junction temperature (T_J) is given by $T_A + P_D \cdot \theta_{JA}$. The total internal power dissipation (P_D) is the sum of quiescent power (P_{DQ}) and additional power dissipated in the output stage (P_{DL}) to deliver load power. Quiescent power is simply the specified no-load supply current times the total supply voltage across the part. P_{DL} will depend on the required output signal and load but would, for a grounded resistive load, be at a maximum when the output is fixed at a voltage equal to $1/2$ either supply voltage (for equal bipolar supplies). Under this condition $P_{DL} = V_S^2 / (4 \cdot R_L)$ where R_L includes feedback network loading.

Note that it is the power in the output stage and not into the load that determines internal power dissipation.

As a worst case example, compute the maximum T_J using an OPA643N (SOT23-5 package) in the circuit of Figure 1 operating at the maximum specified ambient temperature of $+85^\circ\text{C}$. $P_D = 10\text{V} \cdot 26\text{mA} + 5^2 / (4 \cdot (100\Omega \parallel 502\Omega)) = 335\text{mW}$. Maximum $T_J = +85^\circ\text{C} + (0.335\text{W} \cdot 150^\circ\text{C/W}) = 135^\circ\text{C}$.

BOARD LAYOUT GUIDELINES

Achieving optimum performance with a high frequency amplifier like the OPA643 requires careful attention to board layout parasitics and external component types. Recommendations that will optimize performance include:

a) **Minimize parasitic capacitance** to any AC ground for all of the signal I/O pins. Parasitic capacitance on the output and inverting input pins can cause instability; on the non-inverting input, it can react with the source impedance to cause unintentional bandlimiting. To reduce unwanted capacitance, a window around the signal I/O pins should be opened in all of the ground and power planes around those pins. Otherwise, ground and power planes should be unbroken elsewhere on the board.

b) **Minimize the distance** ($< 0.25''$) from the power supply pins to high frequency $0.1\mu\text{F}$ decoupling capacitors. At the device pins, the ground and power plane layout should not be in close proximity to the signal I/O pins. Avoid narrow power and ground traces to minimize inductance between the pins and the decoupling capacitors. The primary power supply connections (on pins 4 and 7) should always be decoupled with these capacitors. Optional output stage power supply connections on pins 5 and 8 may be used to get a slight improvement in harmonic distortion and settling time (for the 8-pin packaged parts). Place additional $0.1\mu\text{F}$ decoupling capacitors very near to these pins to improve performance. Larger ($2.2\mu\text{F}$ to $6.8\mu\text{F}$) decoupling capacitors, effective at lower frequency, should also be used on the main supply pins. These may be placed somewhat farther from the device and may be shared among several devices in the same area of the PC board.

c) **Careful selection and placement of external components will preserve the high frequency performance of the OPA643.** Resistors should be a very low reactance type. Surface mount resistors work best and allow tighter overall layout. Metal film and carbon composition axially leaded resistors can also provide good high frequency performance. Again, keep their leads and PC board trace length as short as possible. Never use wirewound type resistors in a high frequency application. Since the output pin and inverting input pin are the most sensitive to parasitic capacitance, always position the feedback and series output resistor, if any, as close as possible to the output pin. Other network components, such as non-inverting input termination resistors, should also be placed close to the package. Where double side component mounting is allowed, place the feedback resistor directly under the package on the other side of the board between the output and inverting input pins. Even with a low parasitic capacitance shunting the external resistors, excessively high resistor values can create significant time constants that can degrade performance. Good axial metal film or surface mount resistors have approximately 0.2pF in shunt with the resistor. For resistor values $> 1.5\text{k}\Omega$, this parasitic capacitance can add a pole and/or zero below 500MHz that can effect circuit operation. Keep resistor values as low as possible consistent with load driving considerations. The 402Ω feedback used in the typical performance specifications is a good starting point for design.

d) **Connections to other wideband devices** on the board may be made with short direct traces or through on-board transmission lines. For short connections, consider the trace and the input to the next device as a lumped capacitive load. Relatively wide traces (50 to 100mils) should be used, preferably with ground and power planes opened up around them. Estimate the total capacitive load and set R_S from the plot of recommended R_S vs Capacitive Load. Low parasitic capacitive loads ($< 5\text{pF}$) may not need an R_S since the OPA643 is nominally compensated to operate with a 2pF parasitic load. Higher parasitic

capacitive loads without an R_S are allowed as the signal gain increases (increasing the unloaded phase margin). If a long trace is required, and the 6dB signal loss intrinsic to a doubly terminated transmission line is acceptable, implement a matched impedance transmission line using microstrip or stripline techniques (consult an ECL design handbook for microstrip and stripline layout techniques). A 50Ω environment is normally not necessary on board, and in fact a higher impedance environment will improve distortion as shown in the distortion vs load plots. With a characteristic board trace impedance defined based on board material and trace dimensions, a matching series resistor into the trace from the output of the OPA643 is used as well as a terminating shunt resistor at the input of the destination device. Remember also that the terminating impedance will be the parallel combination of the shunt resistor and the input impedance of the destination device: this total effective impedance should be set to match the trace impedance. Multiple destination devices are best handled as separate transmission lines, each with their own series and shunt terminations. If the 6dB attenuation of a doubly terminated transmission line is unacceptable, a long trace can be series-terminated at the source end only. Treat the trace as a capacitive load in this case and set the series resistor value as shown in the plot of R_S vs Capacitive Load. This will not preserve signal integrity as well as a doubly terminated line. If the input impedance of the destination device is low, there will be some signal attenuation due to the voltage divider formed by the series output into the terminating impedance.

- e) **Socketting a high speed part like the OPA643 is not recommended.** The additional lead length and pin-to-pin capacitance introduced by the socket can create an extremely troublesome parasitic network which can make it almost impossible to achieve a smooth, stable frequency response. Best results are obtained by soldering the OPA643 onto the board. If socketting for the DIP package is desired, high frequency flush mount pins (e.g., McKenzie Technology #710C) can give good results.

INPUT AND ESD PROTECTION

The OPA643 is built using a very high speed complementary bipolar process. The internal junction breakdown voltages are relatively low for these very small geometry devices. These breakdowns are reflected in the Absolute Maximum Ratings table. All device pins are protected with internal ESD protection diodes to the power supplies as shown in Figure 11

These diodes provide moderate protection to input overdrive voltages above the supplies as well. The protection diodes can typically support 30mA continuous current. Where higher currents are possible (e.g. in systems with $\pm 15V$ supply parts driving into the OPA643), current limiting series resistors should be added into the two inputs. Keep these resistor values as low as possible since high values degrade both noise performance and frequency response.

High input overdrive signals can also cause significant differential voltage between the + and - inputs. Where this voltage can exceed the maximum rated voltage of $\pm 1.2V$, external Schottky protection diodes should be added across the two inputs. Again, the capacitance added by these diodes can degrade the noise and AC performance and should be used only where necessary. Figure 12 shows a fully featured input protection circuit for the OPA643. This is the circuit of Figure 1 with additional limiting resistors into the inputs and Schottky clamp diodes across the inputs. These resistor values have been selected to limit the degradation in noise and frequency response, achieve DC bias current cancellation, and limit the current that will flow under overdrive conditions.

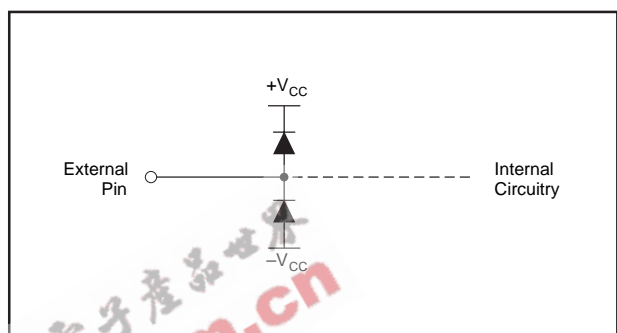

FIGURE 11. Internal ESD Protection.

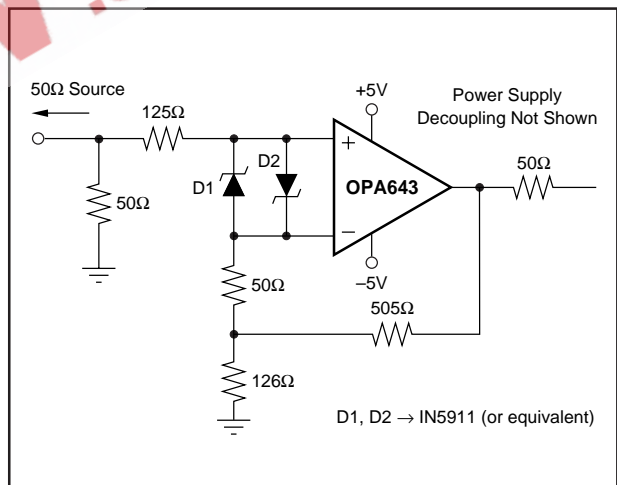

FIGURE 12. OPA643 Gain of +5 with Input Protection.

DESIGN-IN TOOLS

DEMONSTRATION BOARDS

Several PC boards are available in the initial evaluation of circuit performance using the OPA643 in its three package styles. Two partially assembled boards are available for sale to support the DIP (P suffix) and SO-8 (U-suffix) packages. These boards come partially assembled with power supply and I/O connectors but do not have the amplifier or resistor networks loaded. Both boards are configured for low

distortion, non-inverting amplifier operation. Order these boards by the following part numbers from your local Burr-Brown distributor:

DEM-OPA64XP-N for the OPA643P and OPA643PB (8-pin DIP package)

DEM-OPA64XU-N for the OPA643U and OPA643UB (8-pin SO package)

The SOT23-5 package version of the OPA643 may be evaluated using a single unpopulated board used for numerous SOT23-5 packaged amplifiers available from Burr-Brown. This board is available from the Burr-Brown Literature department as an unpopulated board attached to a descriptive document. This board, the **DEM-OPA6xxN**, is available free by requesting literature number **MKT-348**.

MACROMODELS AND APPLICATIONS SUPPORT

Computer simulation of circuit performance using SPICE is often useful when analyzing the performance of analog circuits and systems. This is particularly true for video and RF amplifier circuits where parasitic capacitance and inductance can have a major effect on circuit performance. A SPICE model for the OPA643 is available through the Burr-Brown Internet web page (<http://www.burr-brown.com>) or as a disk from the Burr-Brown Applications department (1-800-548-6132). The Application department is also available for design assistance at this number. These models do a good job of predicting small signal AC and transient performance under a wide variety of operating conditions. They do not do as well in predicting the harmonic distortion or dG/dP characteristics. These models do not attempt to distinguish among the various package types in their small signal AC performance.

EEPW 电子产品世界
.com.cn