

Fiber Optic GaAlAs LED

Types OPF320A, OPF320B, OPF320C

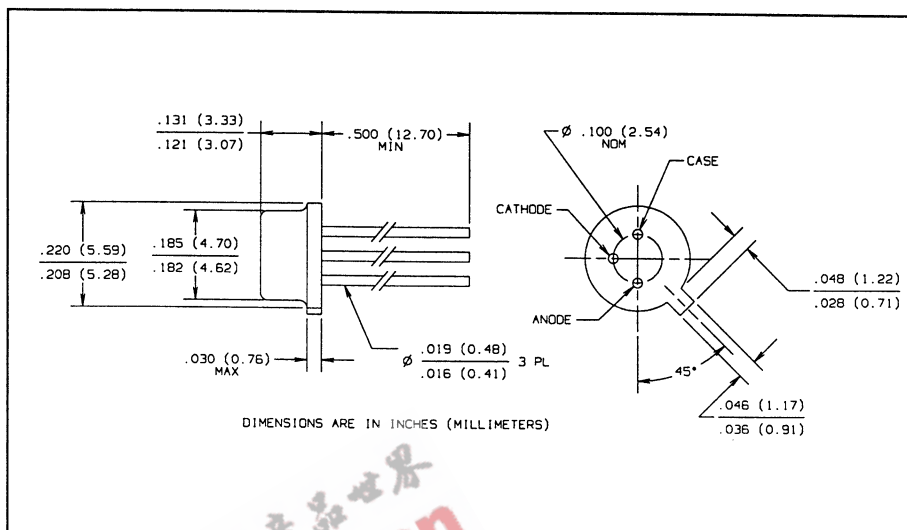
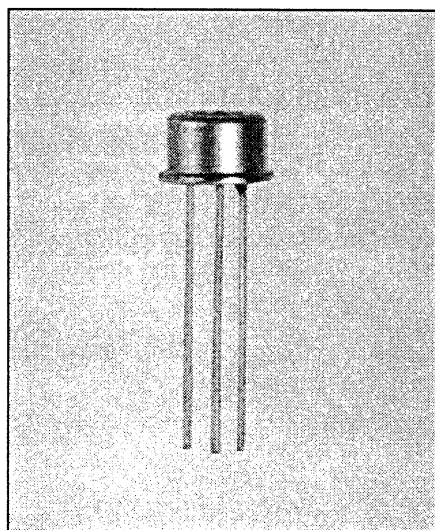

Features

- High radiant output for fiber optic applications
- High speed
- Electrically isolated from case

Description

The OPF320 series LED provides fiber optic users with high coupled power and wide bandwidth in an easily mounted hermetic package.

The LED's are designed to interface with multimode optical fibers from 50/125 to 200/300 microns.

Absolute Maximum Ratings (T_A = 25° C unless otherwise noted)

Reverse Voltage	1.0 V
Continuous Forward Current	100 mA ⁽⁴⁾
Storage Temperature Range	-55° C to +150° C
Operating Temperature Range	-40° C to +125° C
Lead Soldering Temperature [1/16 inch (1.6 mm) from case for 5 sec. with soldering iron]	240° C ⁽¹⁾

Notes:

- (1) RMA flux is recommended. Duration can be extended to 10 sec. max when flow soldering.
- (2) Graded index fiber, 50 μm core, N.A. = 0.20.
- (3) To convert radiant power output to dBm, use the following expression: dBm = 10 log (μW/1000).
- (4) Derate linearly @ 1.0 mA/° C above 25° C.
- (5) Prebias @ 5 mA current.

LED Burn-in

All LED's are subject to 100% burn-in testing. Test conditions are 96 hours at 100 mA continuous current in 25° C ambient.

TYPICAL COUPLED POWER into OPTICAL FIBER

Typical Coupled Power I _F = 100 mA @ 25° C					
Fiber	Refractive Index	N.A.	OPF320C	OPF320B	OPF320A
50/125 μm	Graded	0.20	7.5 μW	12.5 μW	19 μW
62.5/125 μm	Graded	0.28	16 μW	22 μW	34 μW
100/140 μm	Graded	0.29	38 μW	62 μW	95 μW
200/300 μm*	Step	0.41	140 μW	235 μW	360 μW

*PCS - Plastic Clad Silica

Types OPF320A, OPF320B, OPF320C

Electrical Characteristics ($T_A = 25^\circ\text{C}$ unless otherwise noted)

SYMBOL	PARAMETER	MIN	TYP	MAX	UNITS	TEST CONDITIONS
P_O	Radiant Power Output	OPF320C	5.0	7.5		$I_F = 100\text{ mA}^{(2)}$
		OPF320B	10.0	12.5	μW	
		OPF320A	15.0	19.0		
V_F	Forward Voltage		1.8	2.0	V	$I_F = 100\text{ mA}$
λ_p	Peak Output Wavelength	830	850	870	nm	$I_F = 50\text{ mA}$
B	Spectral Bandwidth Between Half Power Points		35		nm	$I_F = 50\text{ mA}$
t_r	Output Rise Time		6.0	8.0	ns	$I_F = 100\text{ mA}, 10\%-90\%^{(5)}$
t_f	Output Fall Time		6.0	10.0	ns	$I_F = 100\text{ mA}, 90\%-10\%^{(5)}$

Typical Performance Curves

