

# Reflective Object Sensors

## Types OPB740W, OPB741W, OPB742W, OPB743W, OPB744W

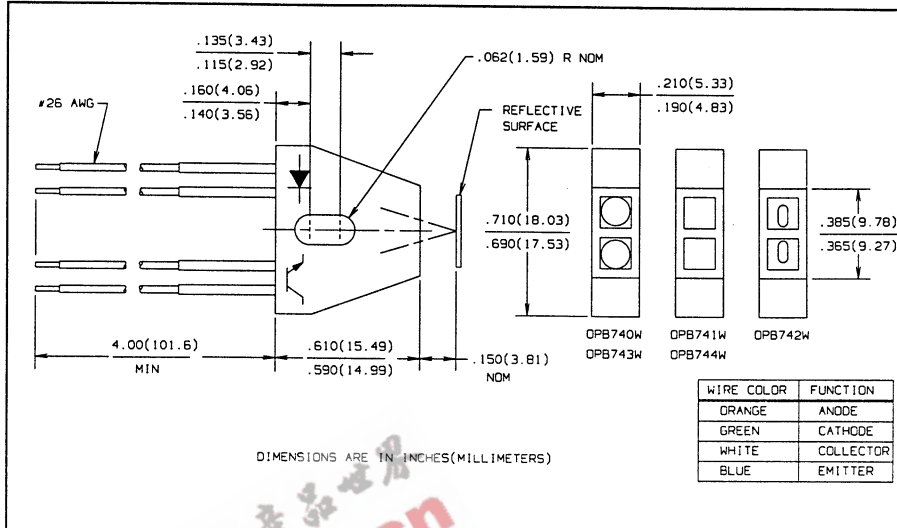
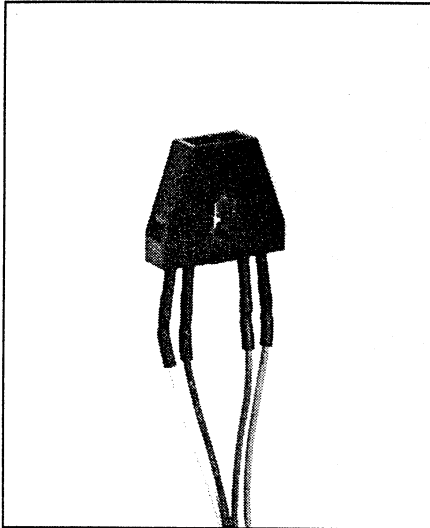

### Features

- Focused for maximum sensitivity
- Phototransistor output
- Low cost plastic housing
- 4.0" min 26 AWG wire leads

### Description

The OPB740W through OPB744W reflective object sensors each consist of an infrared emitting diode and an NPN silicon phototransistor mounted side by side on converging optical axes in a black plastic housing. Various options include choice of no windows, blue polysulfone windows for dust protection or opaque windows with offset openings for improved resolution. Available with PC board mounting as OPB740/OPB744 series.

The photosensor responds to radiation from the emitter only when a reflective object passes within its field of view.

### Absolute Maximum Ratings (T<sub>A</sub> = 25° C unless otherwise noted)

Storage and Operating Temperature Range ..... -40° C to +80° C  
Lead Soldering Temperature [1/16 inch (1.6 mm) from case for 5 sec. with soldering iron] ..... 240° C<sup>(1)</sup>

### Input Diode

Continuous Forward Current ..... 40 mA  
Reverse Voltage ..... 2.0 V  
Power Dissipation ..... 100 mW<sup>(2)</sup>

### Output Photosensor

Collector-Emitter Voltage ..... 30 V  
Emitter-Collector Voltage ..... 5.0 V  
Power Dissipation ..... 100 mW<sup>(2)</sup>

### Notes:

- (1) RMA flux is recommended. Duration can be extended to 10 sec. max. when flow soldering.
- (2) Derate Linearly 1.82 mW/° C above 25° C.
- (3) d is distance from the assembly face to the reflective surface.
- (4) Reflective surface is Eastman Kodak neutral white test card with 90% diffuse reflectance as a reflecting surface. Reference: Eastman Kodak, Catalog #1257795.
- (5) Lower curve is based on calculated worst case condition rather than the conventional -2σ limit.
- (6) Crosstalk is the photocurrent measured with current to the input diode & no reflecting surface.
- (7) All parameters tested using pulse technique.

### DESCRIPTION

OPB740W	No windows
OPB741W	Blue windows
OPB742W	Offset windows
OPB743W	No windows
OPB744 W	Blue windows

# Types OPB740W, OPB741W, OPB742W, OPB743W, OPB744W

Electrical Characteristics ( $T_A = 25^\circ\text{C}$  unless otherwise noted)

SYMBOL	PARAMETER	MIN	MAX	UNITS	TEST CONDITIONS
<b>Input Diode</b>					
$V_F$	Forward Voltage		1.70	V	$I_F = 40\text{ mA}$
$I_R$	Reverse Current		100	$\mu\text{A}$	$V_R = 2.0\text{ V}$
<b>Output Phototransistor</b>					
$V_{(BR)CEO}$	Collector-Emitter Breakdown Voltage	30		V	$I_C = 100\ \mu\text{A}$
$V_{(BR)ECO}$	Emitter-Collector Breakdown Voltage	5.0		V	$I_E = 100\ \mu\text{A}$
$I_{CEO}$	Collector Dark Current		100	nA	$V_{CE} = 10\text{ V}, I_F = 0, E_e = 0$
<b>Combined</b>					
$I_{C(ON)}^{(3)(4)}$	On-State Collector Current	OPB740W/OPB741W OPB742W OPB743W/OPB744W	50 10 200	$\mu\text{A}$ $\mu\text{A}$ $\mu\text{A}$	$V_{CE} = 5\text{ V}, I_F = 40\text{ mA}, d = 0.15''$ $V_{CE} = 5\text{ V}, I_F = 40\text{ mA}, d = 0.15''$ $V_{CE} = 5\text{ V}, I_F = 40\text{ mA}, d = 0.15''$
$I_{CX}^{(6)}$	Crosstalk	OPB740W/OPB741W OPB742W OPB743W/OPB744W		10 100 20	$\mu\text{A}$ nA $\mu\text{A}$ $V_{CE} = 5\text{ V}, I_F = 40\text{ mA}$ $V_{CE} = 5\text{ V}, I_F = 40\text{ mA}$ $V_{CE} = 5\text{ V}, I_F = 40\text{ mA}$

REFLECTIVE OBJECT SENSORS

## Typical Performance Curves

**Collector Current vs. Diode Forward Current**

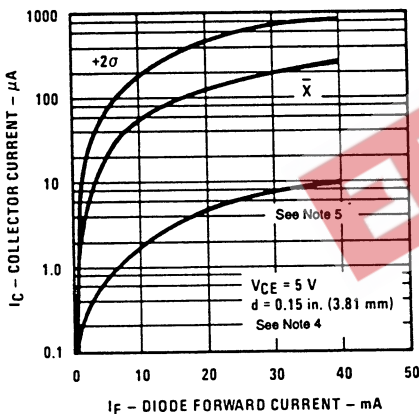

**Normalized Collector Current vs. Ambient Temperature**

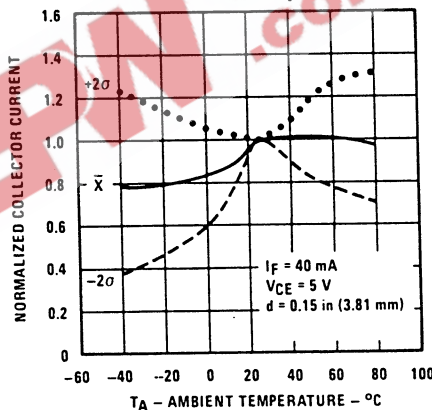

**Normalized Collector Current vs. Object Distance**

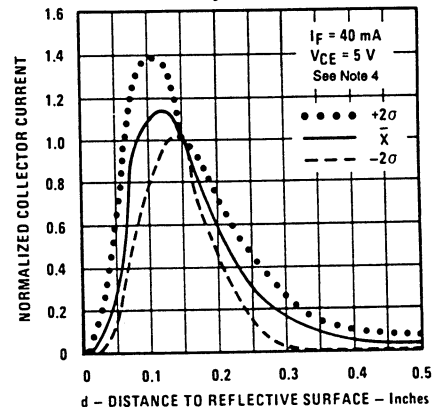

**Rise and Fall Time vs. Load Resistance**

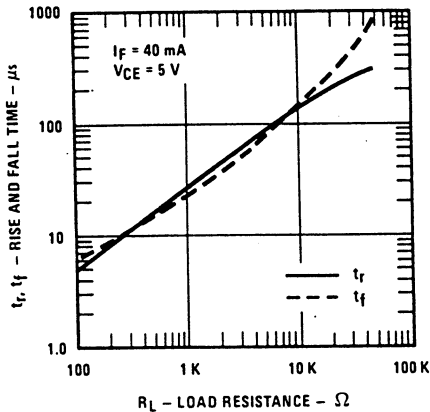

**Test Condition**

