

Vertical Cavity Surface Emitting Laser in TO-46 Package



OPV310, OPV310Y

Technical Data

Features

- 850nm VCSEL Technology
- Data rates up to 2.5 Gbps
- High thermal stability
- Low drive current/high output density
- Narrow and concentric beam angle
- Recommended for multimode fiber applications
- TO-46 package with flat lens
- Burned in for communication level reliability
- Monitor photodiode

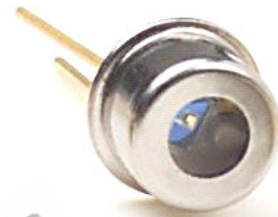

Description

The OPV310 is a high performance 850nm VCSEL packaged for high speed communication links. OPV310 combines all the performance advantages of a VCSEL with the addition of a power monitor diode for precise control of optical power.

The OPV310Y is identical electrically and optically and differs only in pin out. Refer to mechanical drawings for details.

This product's combination of features including high speed, high output power and concentric beam makes it an ideal transmitter for integration into all types of data communications equipment.

Applications include:

- ◆ Fibre Channel
- ◆ Gigabit Ethernet
- ◆ ATM
- ◆ VSR
- ◆ Intra-system links
- ◆ Optical backplane interconnects.

Absolute Maximum Ratings ($T_A = 25^\circ\text{C}$ unless otherwise noted)

Storage Temperature	-40° C to +100° C
Operating Temperature	0° C to +70° C
Soldering Lead Temperature	260° C for 10 Seconds
Maximum Forward Peak Current	20 mA
Maximum Reverse Voltage	10 V
Max. Continuous Optical Power at 70° C	1.1 mW



Additional laser safety information can be found on the Optek website. See application #221. Classification is not marked on the device due to space limitations. See package outline for centerline of optical radiance. Operating devices beyond maximum rating may cause devices to exceed rated classification

September 2003
Issue 3.2

OPV310, OPV310Y Technical Data



Electrical/Optical Characteristics (at 25 °C unless otherwise specified)

SYMBOL	PARAMETER	MIN	TYP	MAX	UNITS	TEST CONDITION
P_{OT}	Total Power Out	1.50			mW	$I_F = 7 \text{ mA}$
I_{TH}	Threshold Current	0.80		3.00	mA	Note 1
V_F	Forward Voltage	1.60		2.20	V	$I_F = 7 \text{ mA}$
I_R	Reverse Current			35	nA	$V_R = 5 \text{ V}$
R_S	Series Resistance	20		55	ohms	Note 2
η	Slope Efficiency	0.28		0.6	mW/mA	Note 3
	Linearity	0.00				Note 4
λ	Wavelength	840	850	860	nm	
$\Delta\lambda$	Optical Bandwidth			0.85	nm	
t_r/t_f	Rise and Fall Time		100		ps	20% to 80%
N_{RI}	Relative Intensity Noise		-123		db/Hz	
$\Delta I_{TH}/\Delta T$	Temp Coefficient of Threshold Current		± 1.0		mA	0° - 70° C, Note 1
$\Delta\lambda/\Delta T$	Temp Coefficient of Wavelength		0.06		%/°C	0° - 70° C, $I_F = 7 \text{ mA}$
$\Delta V_F/\Delta T$	Temperature Coefficient for VF		-2.5		mV/°C	0° - 70° C, $I_F = 7 \text{ mA}$
$\Delta\eta/\Delta T$	Temperature Coefficient for Efficiency		-0.5		%/C	0° - 70° C, Note 3

Photodiode Electrical Characteristics (at 25 °C unless otherwise specified)

SYMBOL	PARAMETER	MIN	TYP	MAX	UNITS	TEST CONDITION
I_{RPD}	Reverse Current, photo diode			30	nA	$V_R = 5 \text{ V}$
I_{M1}	Monitor Current	30			μA	$I_F = 7 \text{ mA}$
I_{M2}	Monitor Current	40			μA	$P_O = 2 \text{ mW}$, $V_R = 5 \text{ V}$

NOTES:

- (1) Threshold Current is based on the two line intersection method specified in Telcordia GR-468-Core. Line 1 from 4 mA to 6 mA. Line 2 from 0 mA to 0.5 mA.
- (2) Series Resistance is the slope of the Voltage-Current line from 5 to 8 mA.
- (3) Slope efficiency, is the slope of the best fit LI line from 5 mA to 8 mA using no larger than 0.25 mA test interval points.
- (4) Using data points taken for slope efficiency above, $\Delta L/\Delta I$ shall be calculated for each adjacent pair of points.

OPV310, OPV310Y Technical Data



Normalized Output Power vs. Forward Current

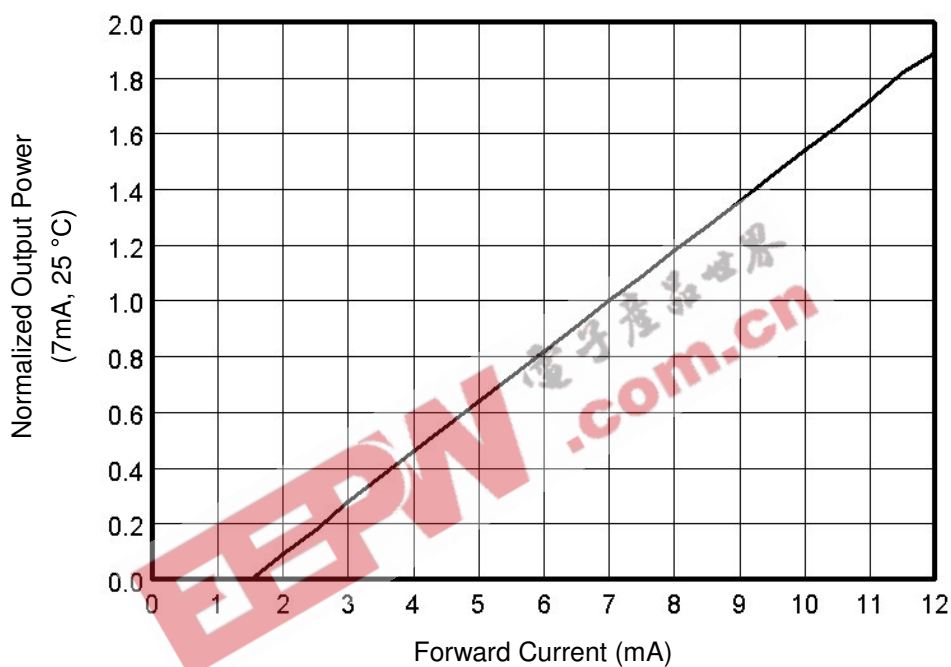

OPV310, OPV310Y Technical Data

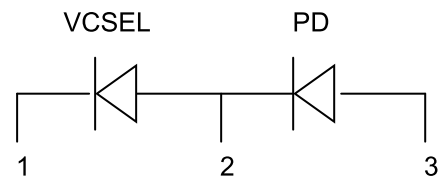
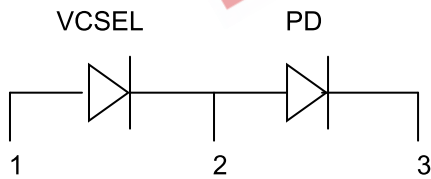
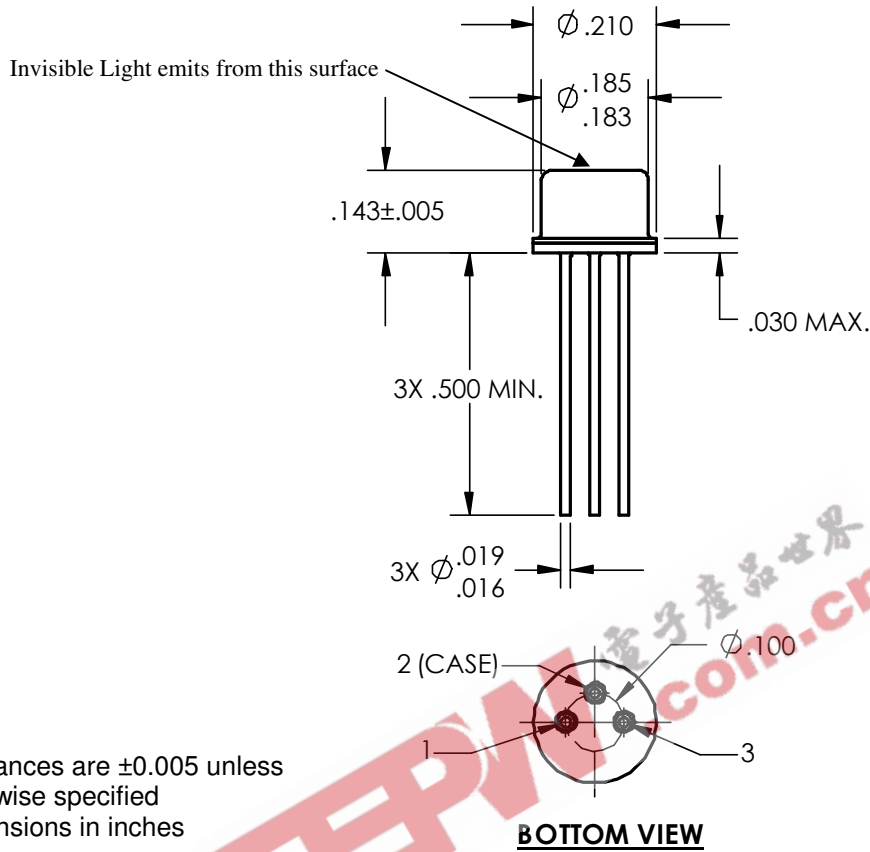

OPV310	
Pin	Connection
1	VCSEL Anode
2	VCSEL Cathode/PD Anode
3	PD Cathode

OPV310Y	
Pin	Connection
1	VCSEL Cathode
2	VCSEL Anode/PD Cathode
3	PD Anode