



OPA547

High-Voltage, High-Current OPERATIONAL AMPLIFIER

FEATURES

- **WIDE SUPPLY RANGE**
Single Supply: +8V to +60V
Dual Supply: $\pm 4V$ to $\pm 30V$
- **HIGH OUTPUT CURRENT:**
500mA Continuous
- **WIDE OUTPUT VOLTAGE SWING**
- **FULLY PROTECTED:**
Thermal Shutdown
Adjustable Current Limit
- **OUTPUT DISABLE CONTROL**
- **THERMAL SHUTDOWN INDICATOR**
- **HIGH SLEW RATE:** 6V/ μs
- **LOW QUIESCENT CURRENT**
- **PACKAGES:**
7-Lead TO-220
7-Lead DPAK Surface-Mount

APPLICATIONS

- VALVE, ACTUATOR DRIVER
- SYNCHRO, SERVO DRIVER
- POWER SUPPLIES
- TEST EQUIPMENT
- TRANSDUCER EXCITATION
- AUDIO AMPLIFIER

DESCRIPTION

The OPA547 is a low cost, high-voltage/high-current operational amplifier ideal for driving a wide variety of loads. A laser-trimmed monolithic integrated circuit provides excellent low-level signal accuracy and high output voltage and current.

The OPA547 operates from either single or dual supplies for design flexibility. In single supply operation, the input common-mode range extends below ground.

The OPA547 is internally protected against over-temperature conditions and current overloads. In addition, the OPA547 was designed to provide an accurate, user-selected current limit. Unlike other designs which use a "power" resistor in series with the output current path, the OPA547 senses the load indirectly. This allows the current limit to be adjusted from 0 to 750mA with a 0 to 150 μA control signal. This is easily done with a resistor/potentiometer or controlled digitally with a voltage-out or current-out DAC.

The Enable/Status (E/S) pin provides two functions. An input on the pin not only disables the output stage to effectively disconnect the load but also reduces the quiescent to conserve power. The E/S pin output can be monitored to determine if the OPA547 is in thermal shutdown.

The OPA547 is available in an industry-standard 7-lead staggered TO-220 package and a 7-lead DPAK surface-mount plastic power package. The copper tab allows easy mounting to a heat sink or circuit board for excellent thermal performance. It is specified for operation over the extended industrial temperature range, $-40^{\circ}C$ to $+85^{\circ}C$.

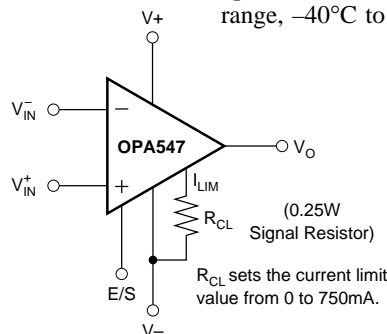

SPECIFICATIONS

At $T_{CASE} = +25^{\circ}C$, $V_S = \pm 30V$ and E/S pin open, unless otherwise noted.

PARAMETER	CONDITION	OPA547T, F			UNITS
		MIN	TYP	MAX	
OFFSET VOLTAGE Input Offset Voltage vs Temperature vs Power Supply	$V_{CM} = 0, I_O = 0$ $T_A = -40^{\circ}C$ to $+85^{\circ}C$ $V_S = \pm 4V$ to $\pm 30V$		± 1 ± 25 10	± 5 100	mV $\mu V/^{\circ}C$ $\mu V/V$
INPUT BIAS CURRENT⁽¹⁾ Input Bias Current ⁽²⁾ vs Temperature Input Offset Current	$V_{CM} = 0V$ $V_{CM} = 0V$		-100 ± 0.5 ± 5	-500 ± 50	nA $nA/^{\circ}C$ nA
NOISE Input Voltage Noise Density, $f = 1kHz$ Current Noise Density, $f = 1kHz$			90 200		nV/\sqrt{Hz} fA/\sqrt{Hz}
INPUT VOLTAGE RANGE Common-Mode Voltage Range: Positive Negative Common-Mode Rejection	Linear Operation Linear Operation $V_{CM} = (V-) - 0.1V$ to $(V+) - 3V$	$(V+) - 3$ $(V-) - 0.1$ 80	$(V+) - 2.3$ $(V-) - 0.2$ 95		V V dB
INPUT IMPEDANCE Differential Common-Mode			$10^7 \parallel 6$ $10^9 \parallel 4$		$\Omega \parallel pF$ $\Omega \parallel pF$
OPEN-LOOP GAIN Open-Loop Voltage Gain, $f = 10Hz$	$V_O = \pm 25V, R_L = 1k\Omega$ $V_O = \pm 25V, R_L = 50\Omega$	100	115 110		dB dB
FREQUENCY RESPONSE Gain-Bandwidth Product Slew Rate Full Power Bandwidth Settling Time: $\pm 0.1\%$ Total Harmonic Distortion + Noise, $f = 1kHz$	$R_L = 50\Omega$ $G = 1, 50Vp-p, R_L = 50\Omega$ $G = -10, 50V$ Step $R_L = 50\Omega, G = +3V, 1W$ Power		1 6 See Typical Curve 18 0.004 ⁽³⁾		MHz V/ μs kHz μs %
OUTPUT Voltage Output, Positive Negative Positive Negative Maximum Continuous Current Output: dc ac Leakage Current, Output Disabled, dc Output Current Limit Current Limit Range Current Limit Equation Current Limit Tolerance ⁽¹⁾ Capacitive Load Drive	$I_O = 0.5A$ $I_O = -0.5A$ $I_O = 0.1A$ $I_O = -0.1A$ $R_{CL} = 31.6k\Omega$ ($I_{LIM} = \pm 375mA$), $R_L = 50\Omega$	$(V+) - 2.2$ $(V-) + 1.6$ $(V+) - 1.8$ $(V-) + 1.2$ ± 500 500	$(V+) - 1.9$ $(V-) + 1.3$ $(V+) - 1.5$ $(V-) + 0.8$ See Typical Curve 0 to ± 750 $I_{LIM} = (5000)(4.75)/(31600\Omega + R_{CL})$ ± 10 See Typical Curve ⁽⁴⁾		V V V V mA mArms mA A mA
OUTPUT ENABLE /STATUS (E/S) PIN Shutdown Input Mode $V_{E/S}$ High (output enabled) $V_{E/S}$ Low (output disabled) $I_{E/S}$ High (output enabled) $I_{E/S}$ Low (output disabled) Output Disable Time Output Enable Time Thermal Shutdown Status Output Normal Operation Thermally Shutdown Junction Temperature, Shutdown Reset from Shutdown	E/S Pin Open or Forced High E/S Pin Forced Low E/S Pin High E/S Pin Low Sourcing $20\mu A$ Sinking $5\mu A, T_J > 160^{\circ}C$	$(V-) + 2.4$ $(V-) + 2.4$	 -60 -65 1 3 $(V-) + 3.5$ $(V-) + 0.35$ $+160$ $+140$	 $(V-) + 0.8$ $(V-) + 0.8$	V V μA μA μs ms V V $^{\circ}C$ $^{\circ}C$
POWER SUPPLY Specified Voltage Operating Voltage Range Quiescent Current Quiescent Current, Shutdown Mode	 I_{LIM} Connected to $V-$, $I_O = 0$ I_{LIM} Connected to $V-$	± 4	± 30 ± 10 ± 4	 ± 30 ± 15	V V mA mA
TEMPERATURE RANGE Specified Range Operating Range Storage Range Thermal Resistance, θ_{JC} 7-Lead DDPAK, 7-Lead TO-220 7-Lead DDPAK, 7-Lead TO-220 Thermal Resistance, θ_{JA} 7-Lead DDPAK, 7-Lead TO-220	 $f > 50Hz$ dc No Heat Sink	-40 -40 -55	 2 3 65	 $+85$ $+125$ $+125$	$^{\circ}C$ $^{\circ}C$ $^{\circ}C$ $^{\circ}C/W$ $^{\circ}C/W$ $^{\circ}C/W$

NOTES: (1) High-speed test at $T_J = +25^{\circ}C$. (2) Positive conventional current flows into the input terminals. (3) See "Total Harmonic Distortion+Noise" in the Typical Performance Curves section for additional power levels. (4) See "Small-Signal Overshoot vs Load Capacitance" in the Typical Performance Curves section.

CONNECTION DIAGRAMS

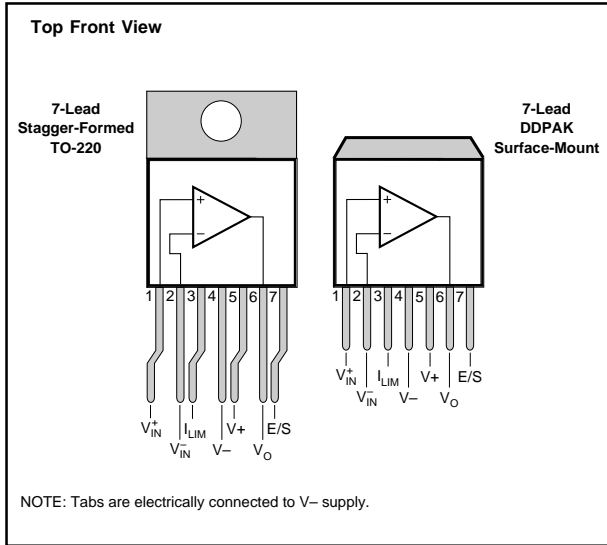

ELECTROSTATIC DISCHARGE SENSITIVITY

This integrated circuit can be damaged by ESD. Burr-Brown recommends that all integrated circuits be handled with appropriate precautions. Failure to observe proper handling and installation procedures can cause damage.

ESD damage can range from subtle performance degradation to complete device failure. Precision integrated circuits may be more susceptible to damage because very small parametric changes could cause the device not to meet its published specifications.

ABSOLUTE MAXIMUM RATINGS

Output Current	See SOA Curve
Supply Voltage, V+ to V-	60V
Input Voltage	(V-)-0.5V to (V+)+0.5V
Input Shutdown Voltage	V+
Operating Temperature	-40°C to +125°C
Storage Temperature	-55°C to +125°C
Junction Temperature	150°C
Lead Temperature (soldering 10s) ⁽²⁾	300°C

NOTE: (1) Stresses above these ratings may cause permanent damage. (2) Vapor-phase or IR reflow techniques are recommended for soldering the OPA547F surface mount package. Wave soldering is not recommended due to excessive thermal shock and "shadowing" of nearby devices.

ORDERING/PACKAGE INFORMATION

PRODUCT	PACKAGE	PACKAGE DRAWING NUMBER ⁽¹⁾	TEMPERATURE RANGE
OPA547T	7-Lead Stagger-Formed TO-220	327	-40°C to +85°C
OPA547F ⁽²⁾	7-Lead DDPAK Surface-Mount	328	-40°C to +85°C

NOTE: (1) For detailed drawing and dimension table, please see end of data sheet. (2) Available on Tape and Reel.

The information provided herein is believed to be reliable; however, BURR-BROWN assumes no responsibility for inaccuracies or omissions. BURR-BROWN assumes no responsibility for the use of this information, and all use of such information shall be entirely at the user's own risk. Prices and specifications are subject to change without notice. No patent rights or licenses to any of the circuits described herein are implied or granted to any third party. BURR-BROWN does not authorize or warrant any BURR-BROWN product for use in life support devices and/or systems.

TYPICAL PERFORMANCE CURVES

At $T_{CASE} = +25^{\circ}C$, $V_S = \pm 30V$ and E/S pin open, unless otherwise noted.

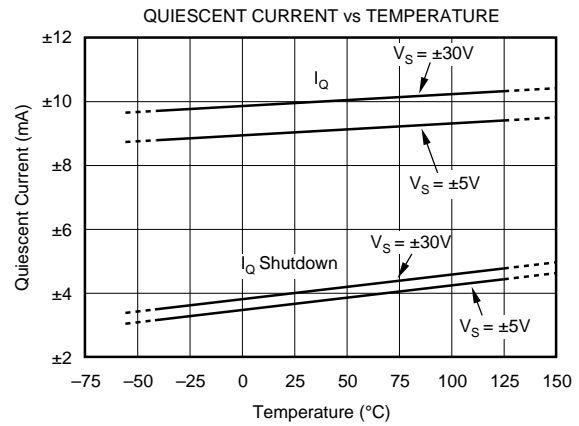
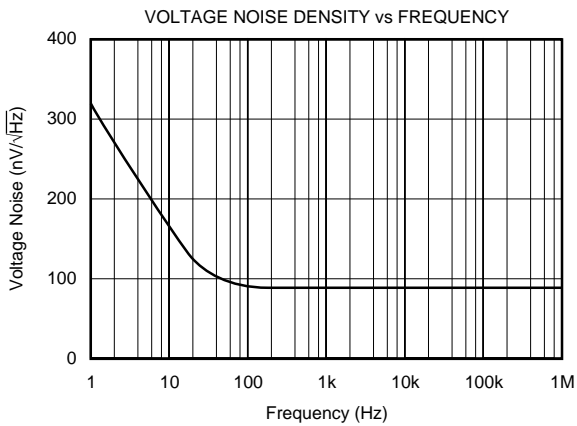
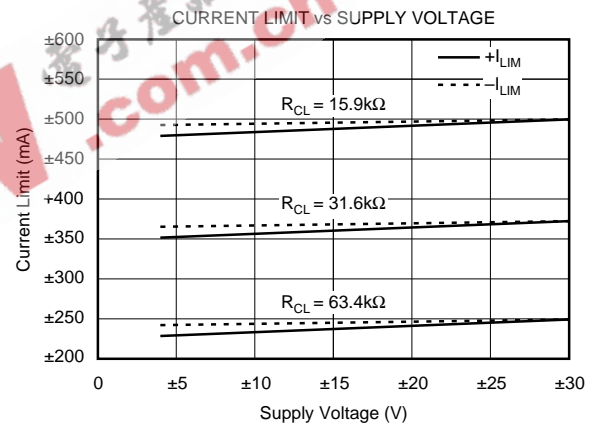
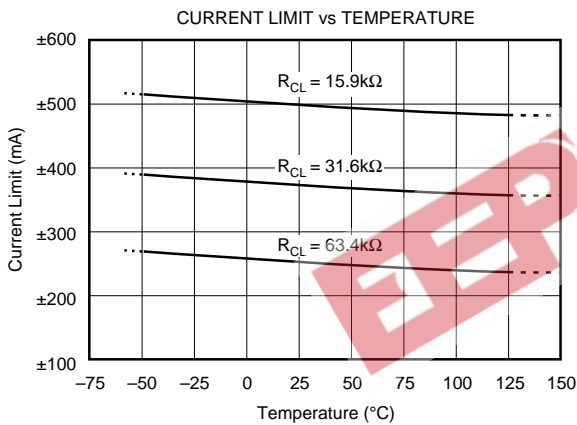
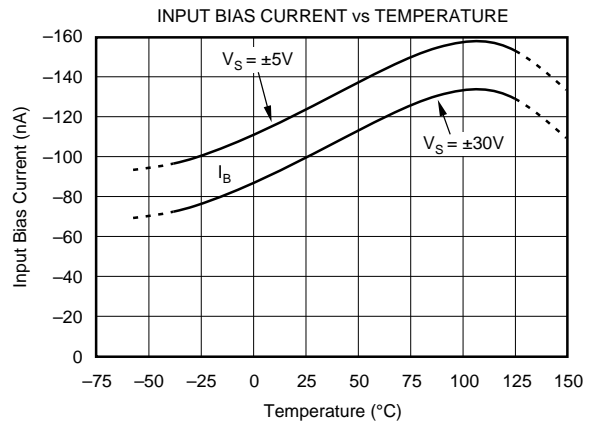
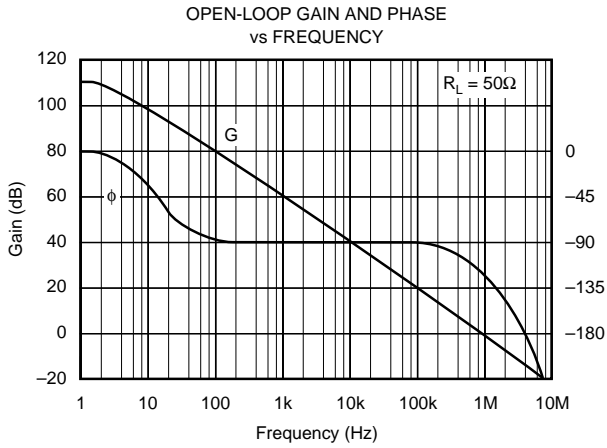

TYPICAL PERFORMANCE CURVES (CONT)

At $T_{CASE} = +25^{\circ}C$, $V_S = \pm 30V$ and E/S pin open, unless otherwise noted.

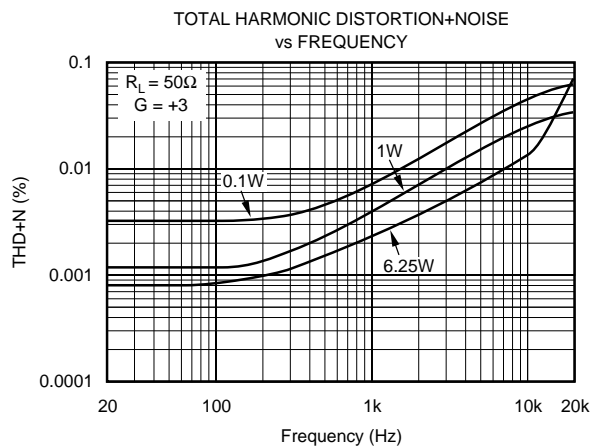
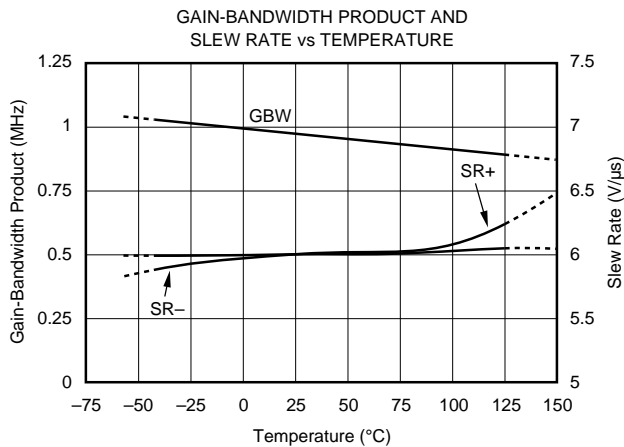
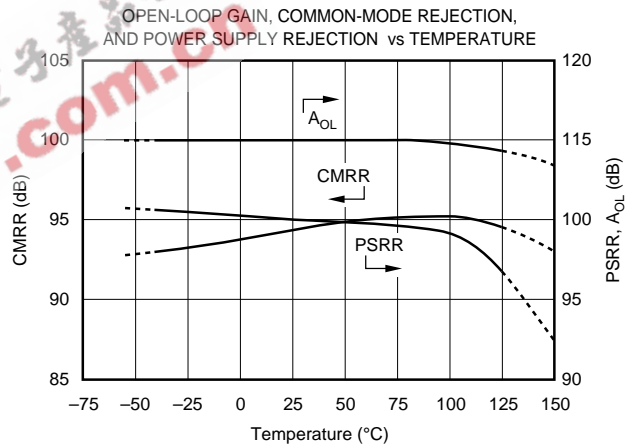
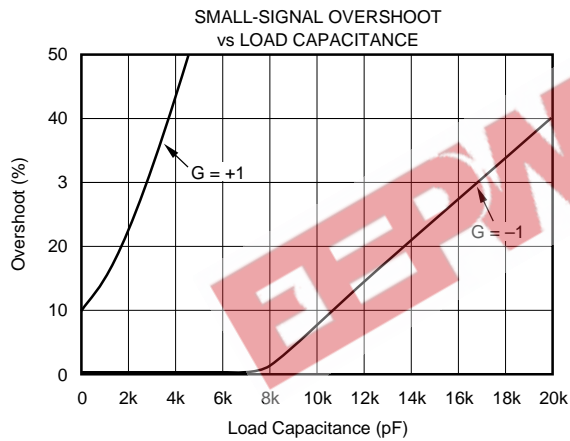
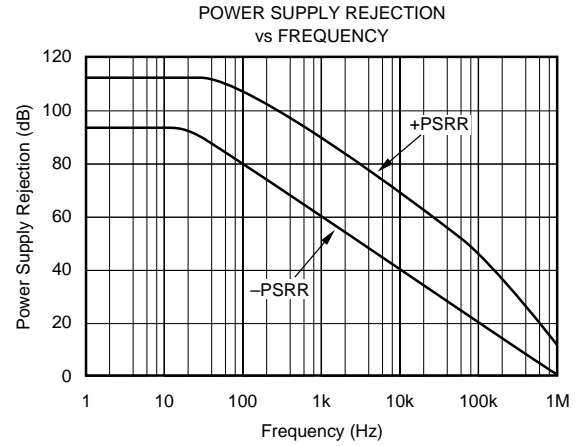
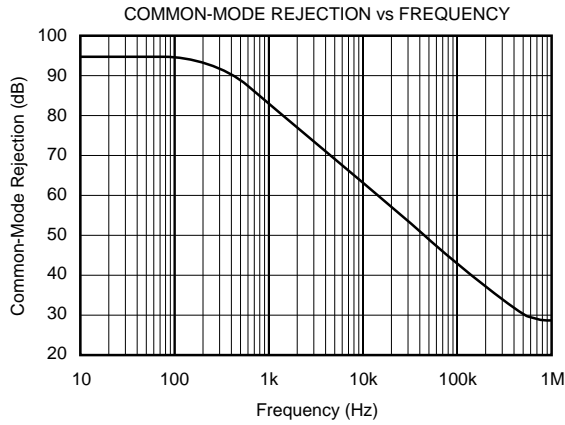

TYPICAL PERFORMANCE CURVES (CONT)

At $T_{CASE} = +25^{\circ}C$, $V_S = \pm 30V$ and E/S pin open, unless otherwise noted.

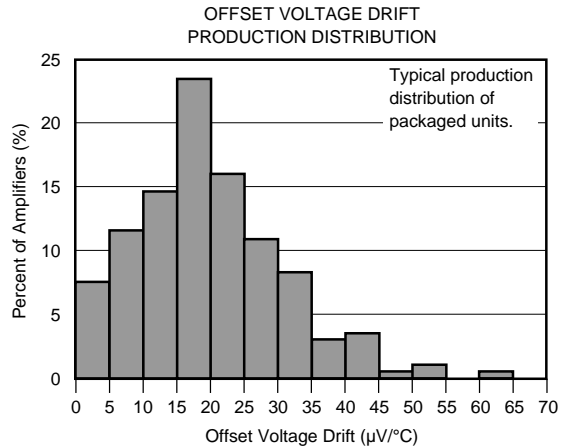
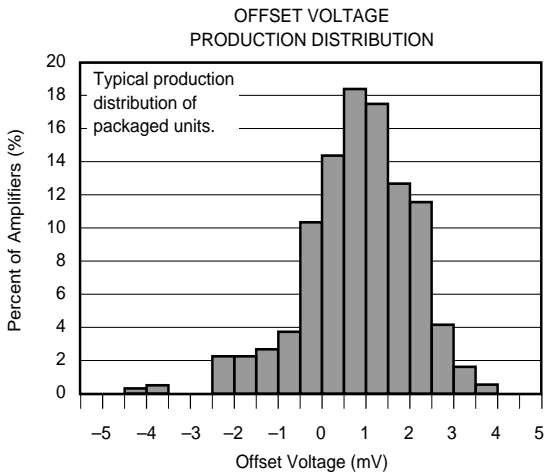
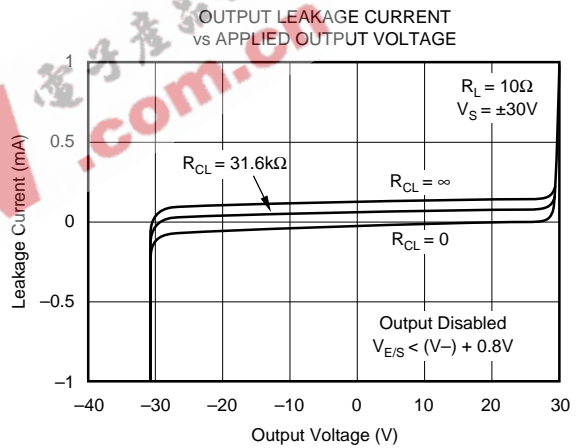
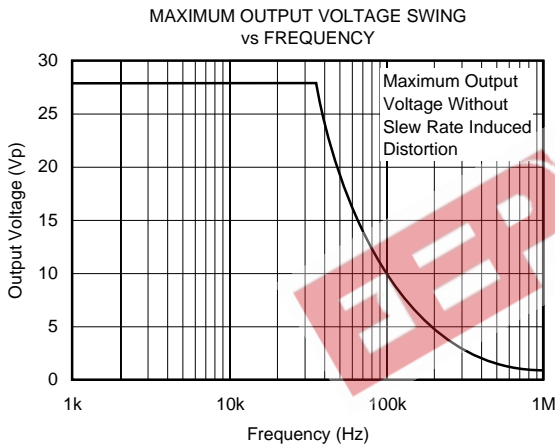
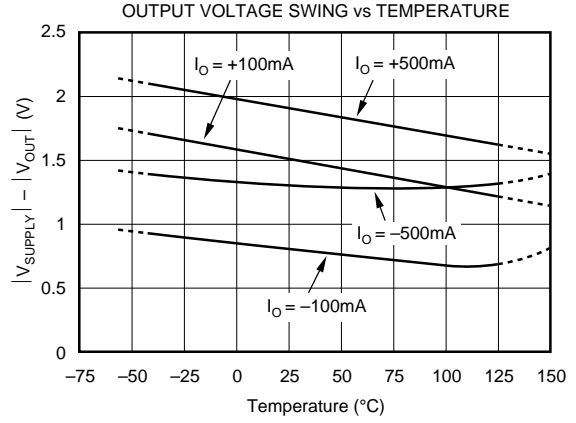
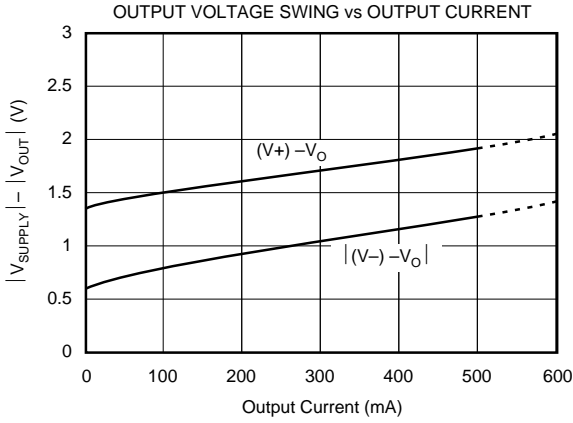

TYPICAL PERFORMANCE CURVES (CONT)

At $T_{CASE} = +25^{\circ}C$, $V_S = \pm 35V$ and E/S pin open, unless otherwise noted.

SMALL SIGNAL STEP RESPONSE
 $G = 1$, $C_L = 1000pF$

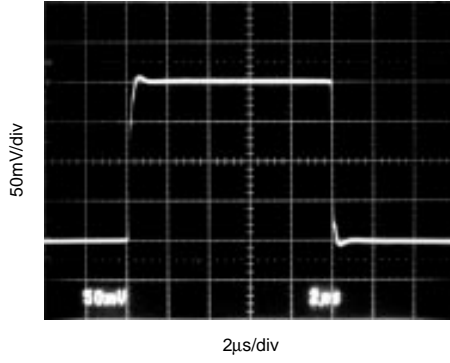

SMALL SIGNAL STEP RESPONSE
 $G = 3$, $C_L = 1000pF$

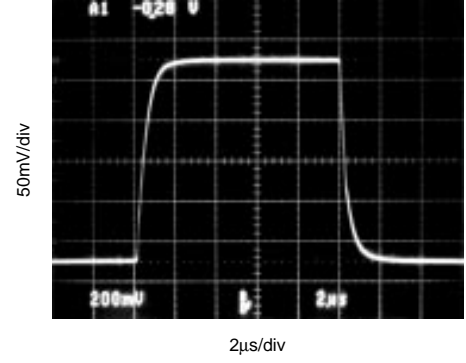

LARGE SIGNAL STEP RESPONSE
 $G = 3$, $C_L = 100pF$, $R_L = 50\Omega$

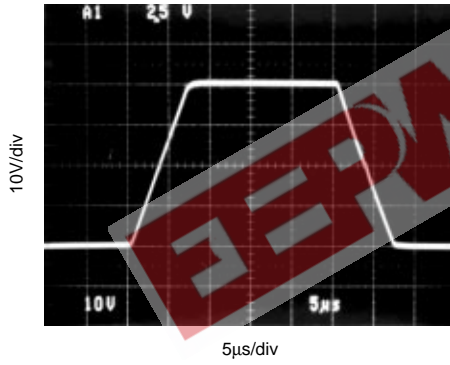

電子產品世界
www.eeworld.com.cn

APPLICATIONS INFORMATION

Figure 1 shows the OPA547 connected as a basic non-inverting amplifier. The OPA547 can be used in virtually any op amp configuration.

Power supply terminals should be bypassed with low series impedance. The technique shown, using a ceramic and tantalum type in parallel is recommended. Power supply wiring should have low series impedance.

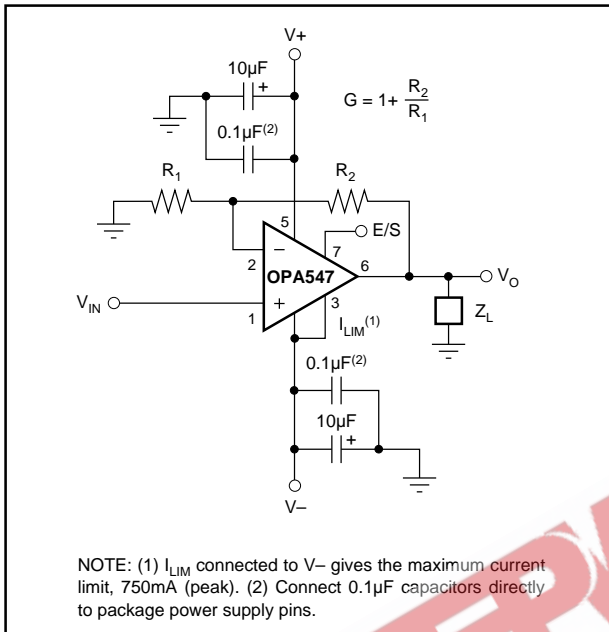

FIGURE 1. Basic Circuit Connections.

POWER SUPPLIES

The OPA547 operates from single (+8V to +60V) or dual ($\pm 4V$ to $\pm 30V$) supplies with excellent performance. Most behavior remains unchanged throughout the full operating voltage range. Parameters which vary significantly with operating voltage are shown in the typical performance curves.

Some applications do not require equal positive and negative output voltage swing. Power supply voltages do not need to be equal. The OPA547 can operate with as little as 8V between the supplies and with up to 60V between the supplies. For example, the positive supply could be set to 55V with the negative supply at -5V, or vice-versa.

ADJUSTABLE CURRENT LIMIT

The OPA547 features an accurate, user-selected current limit. Current limit is set from 0 to 750mA by controlling the input to the I_{LIM} pin. Unlike other designs which use a power resistor in series with the output current path, the OPA547 senses the load indirectly. This allows the current limit to be set with a 0 to 150µA control signal. In contrast, other designs require a limiting resistor to handle the full output current (750mA in this case).

With the OPA547, the simplest method for adjusting the current limit uses a resistor or potentiometer connected between the I_{LIM} pin and $V-$ according to the equation:

$$R_{CL} = \frac{(5000)(4.75)}{I_{LIM}} - 31.6k\Omega$$

The low level control signal (0 to 150µA) also allows the current limit to be digitally controlled with a current-out or voltage-out DAC reference to $V-$ according to the equations given in Figure 3.

Figure 3 shows a simplified schematic of the internal circuitry used to set the current limit. Leaving the I_{LIM} pin open programs the output current to zero, while connecting I_{LIM} directly to $V-$ programs the maximum output current limit, typically 750mA.

SAFE OPERATING AREA

Stress on the output transistors is determined both by the output current and by the output voltage across the conducting output transistor, $V_S - V_O$. The power dissipated by the output transistor is equal to the product of the output current and the voltage across the conducting transistor, $V_S - V_O$. The Safe Operating Area (SOA) curve, Figure 2) shows the permissible range of voltage and current.

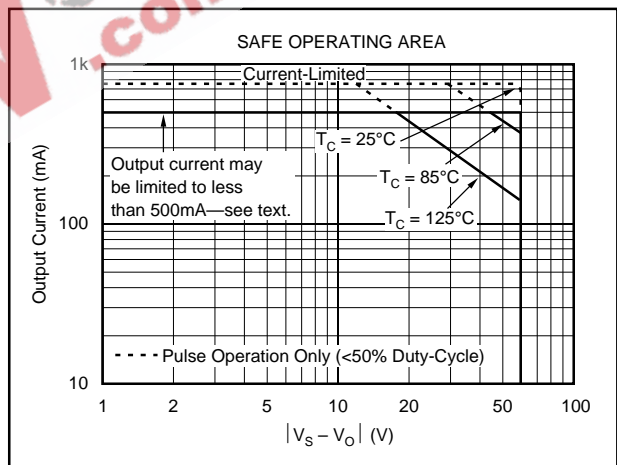

FIGURE 2. Safe Operating Area.

The safe output current decreases as $V_S - V_O$ increases. Output short-circuits are a very demanding case for SOA. A short-circuit to ground forces the full power supply voltage ($V+$ or $V-$) across the conducting transistor. With $T_C = 25^\circ C$ the maximum output current of 500mA can be achieved under most conditions. Increasing the case temperature reduces the safe output current that can be tolerated without activating the thermal shutdown circuit of the OPA547. For further insight on SOA, consult Application Bulletin AB-039.

POWER DISSIPATION

Power dissipation depends on power supply, signal and load conditions. For dc signals, power dissipation is equal to the product of output current times the voltage across the con-

ducting output transistor. Power dissipation can be minimized by using the lowest possible power supply voltage necessary to assure the required output voltage swing.

For resistive loads, the maximum power dissipation occurs at a dc output voltage of one-half the power supply voltage. Dissipation with ac signals is lower. Application Bulletin AB-039 explains how to calculate or measure power dissipation with unusual signals and loads.

HEAT SINKING

Most applications require a heat sink to assure that the maximum junction temperature (150°C) is not exceeded. The

heat sink required depends on the power dissipated and on ambient conditions. Consult Application Bulletin AB-038 for information on determining heat sink requirements. The internal protection circuitry was designed to protect against overload conditions. It does not activate until the junction temperature reaches approximately 160°C and was not intended to replace proper heat sinking. Continuously running the OPA547 into thermal shutdown will degrade reliability.

The tab of the DDPACK surface-mount version should be soldered to a circuit board copper area for good heat dissipation. Figure 4 shows typical thermal resistance from junction to ambient as a function of the copper area.

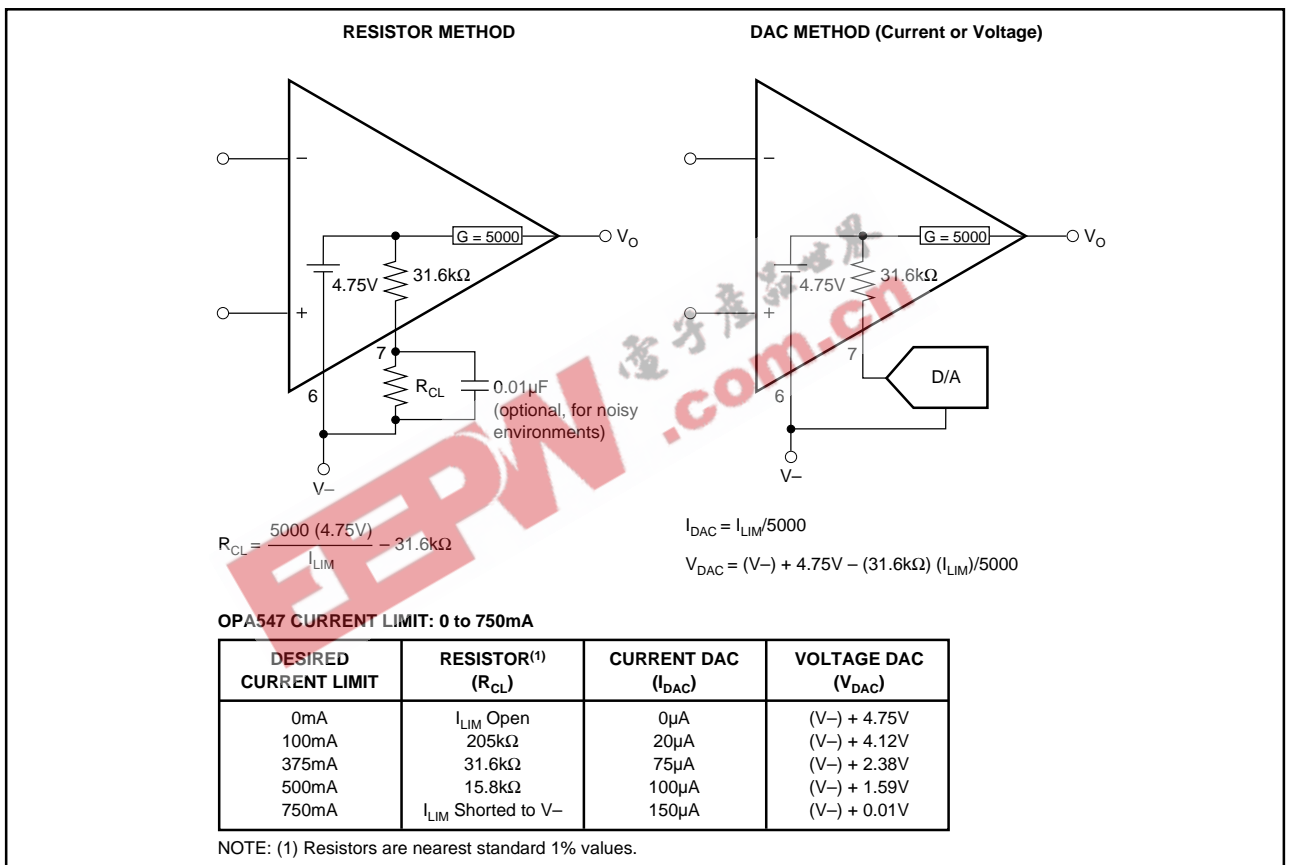

FIGURE 3. Adjustable Current Limit.

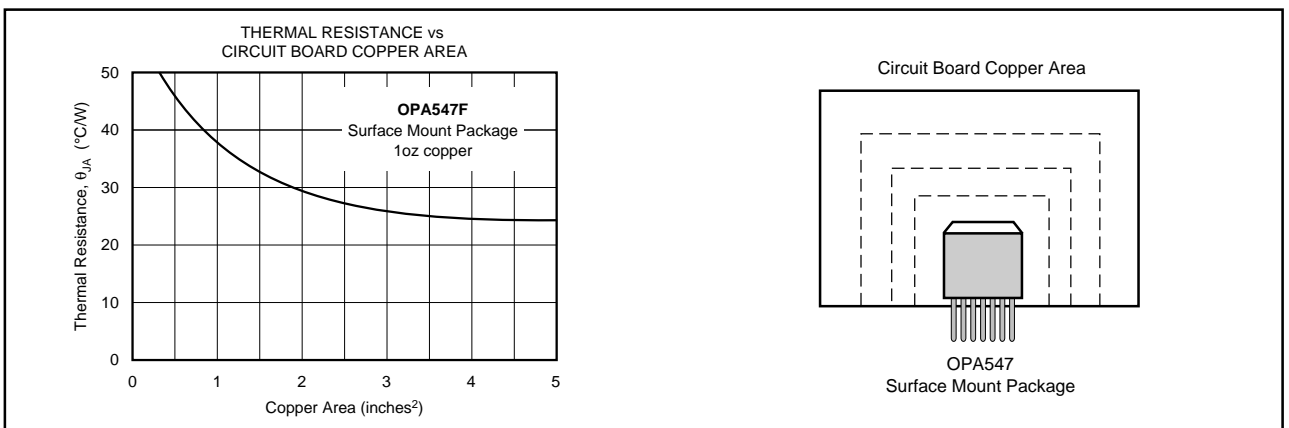

FIGURE 4. Thermal Resistance vs. Circuit Board Copper Area.

THERMAL PROTECTION

The OPA547 has thermal shutdown that protects the amplifier from damage. Activation of the thermal shutdown circuit during normal operation is an indication of excessive power dissipation or an inadequate heat sink. Depending on load and signal conditions, the thermal protection circuit may cycle on and off. This limits the dissipation of the amplifier but may have an undesirable effect on the load.

The thermal protection activates at a junction temperature of approximately 160°C. However, for reliable operation junction temperature should be limited to 150°C. To estimate the margin of safety in a complete design (including heat sink), increase the ambient temperature until the thermal protection is activated. Use worst-case load and signal conditions. For good reliability, the thermal protection should trigger more than 35°C above the maximum expected ambient condition of your application. This produces a junction temperature of 125°C at the maximum expected ambient condition.

ENABLE/STATUS (E/S) PIN

The Enable/Status Pin provides two functions: forcing this pin low disables the output stage, or, E/S can be monitored to determine if the OPA547 is in thermal shutdown. One or both of these functions can be utilized on the same device using single or dual supplies. For normal operation (output enabled), the E/S pin can be left open or pulled high (at least +2.4V above the negative rail).

Output Disable

A unique feature of the OPA547 is its output disable capability. This function not only conserves power during idle periods (quiescent current drops to approximately 4mA) but also allows multiplexing in low frequency ($f < 10\text{kHz}$), multichannel applications. Signals that are greater than 10kHz may cause leakage current to increase in devices that are shutdown. Figure 15 shows the two OPA547s in a switched amplifier configuration. The on/off state of the two amplifiers is controlled by the voltage on the E/S pin.

To disable the output, the E/S pin is pulled low, no greater than 0.8V above the negative rail. Typically the output is shutdown in 1 μs . Figure 5 provides an example of how to implement this function using a single supply. Figure 6 gives a circuit for dual supply applications. To return the output to an enabled state, the E/S pin should be disconnected (open) or pulled to at least $(V-) + 2.4\text{V}$. It should be noted that pulling the E/S pin high (output enabled) does not disable internal thermal shutdown.

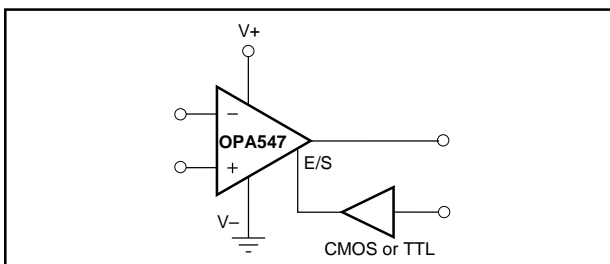

FIGURE 5. Output Disable with a Single Supply.

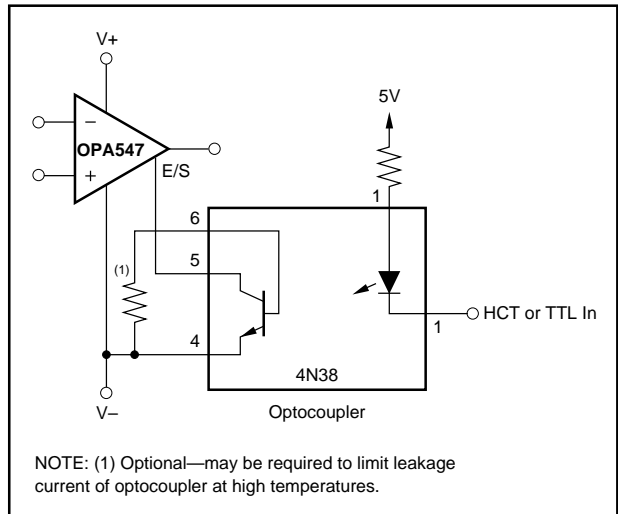

FIGURE 6. Output Disable with Dual Supplies.

Thermal Shutdown Status

Internal thermal shutdown circuitry shuts down the output when the die temperature reaches approximately 160°C, resetting when the die has cooled to 140°C. The E/S pin can be monitored to determine if shutdown has occurred. During normal operation the voltage on the E/S pin is typically 3.5V above the negative rail. Once shutdown has occurred this voltage drops to approximately 350mV above the negative rail.

Figure 7 gives an example of monitoring shutdown in a single supply application. Figure 8 provides a circuit for dual supplies. External logic circuitry or an LED could be used to indicate if the output has been thermally shutdown, see Figure 13.

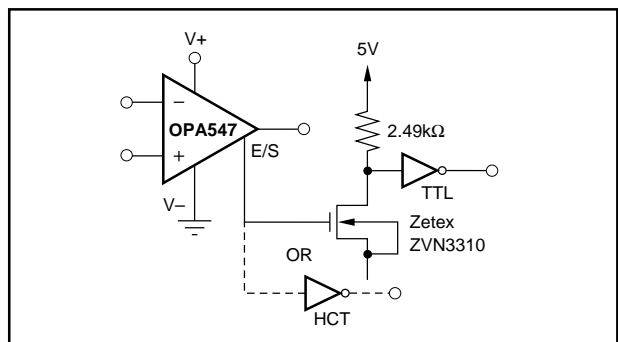

FIGURE 7. Thermal Shutdown Status with a Single Supply.

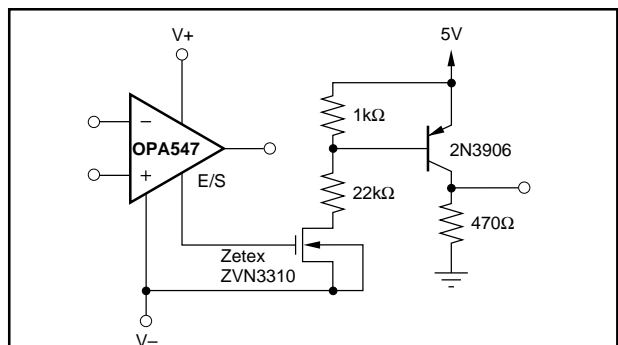

FIGURE 8. Thermal Shutdown Status with Dual Supplies.

Output Disable and Thermal Shutdown Status

As mentioned earlier, the OPA547's output can be disabled and the disable status can be monitored simultaneously. Figures 9 and 10 provide examples using a single supply and dual supplies, respectively.

OUTPUT STAGE COMPENSATION

The complex load impedances common in power op amp applications can cause output stage instability. For normal operation output compensation circuitry is not typically required. However, if the OPA547 is intended to be driven into current limit, a R/C network may be required. Figure 11 shows an output series R/C compensation (snubber) network (3Ω in series with $0.01\mu\text{F}$) which generally provides excellent stability. Some variations in circuit values may be required with certain loads.

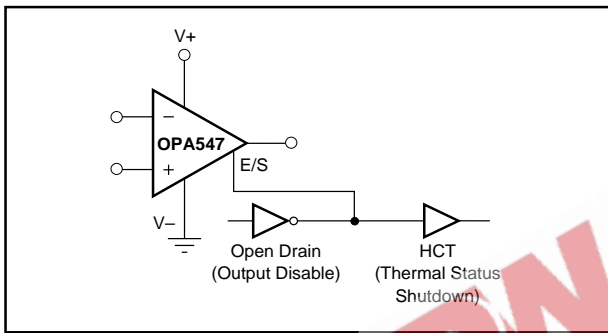

FIGURE 9. Output Disable and Thermal Shutdown Status with a Single Supply.

OUTPUT PROTECTION

Reactive and EMF-generating loads can return load current to the amplifier, causing the output voltage to exceed the power supply voltage. This damaging condition can be avoided with clamp diodes from the output terminal to the power supplies as shown in Figure 11. Schottky rectifier diodes with a 1A or greater continuous rating are recommended.

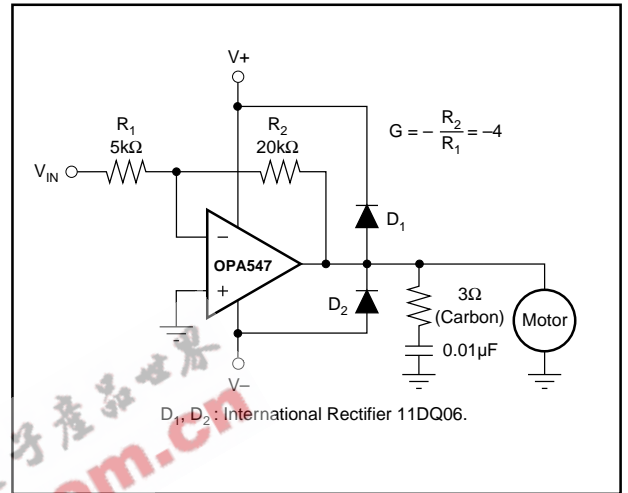

FIGURE 11. Motor Drive Circuit.

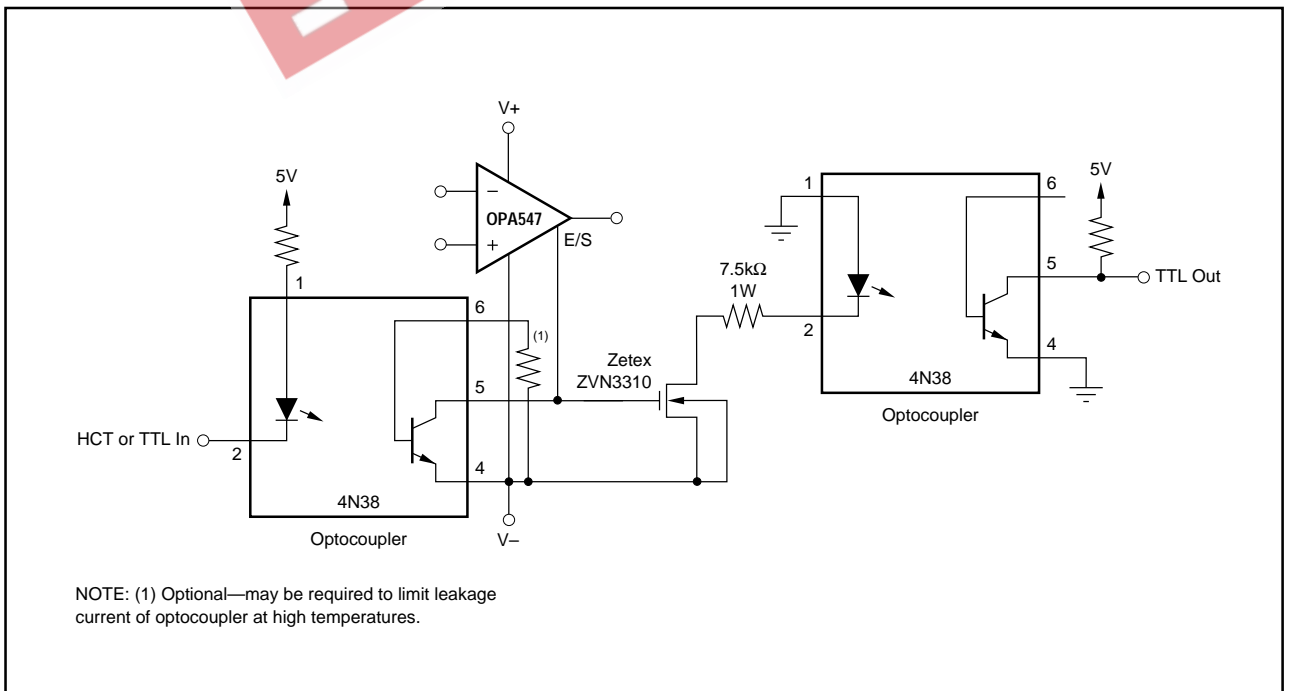

FIGURE 10. Output Disable and Thermal Shutdown Status with Dual Supplies.

VOLTAGE SOURCE APPLICATION

Figure 12 illustrates how to use the OPA547 to provide an accurate voltage source with only three external resistors. First, the current limit resistor, R_{CL} , is chosen according to the desired output current. The resulting voltage at the I_{LIM} pin is constant and stable over temperature. This voltage, V_{CL} , is connected to the noninverting input of the op amp and used as a voltage reference, thus eliminating the need for an external reference. The feedback resistors are selected to gain V_{CL} to the desired output voltage level.

PROGRAMMABLE POWER SUPPLY

A programmable power supply can easily be built using the OPA547. Both the output voltage and output current are user-controlled. Figure 13 shows a circuit using potentiometers to adjust the output voltage and current while Figure 14 uses digital-to-analog converters. An LED tied to the E/S pin through a logic gate indicates if the OPA547 is in thermal shutdown.

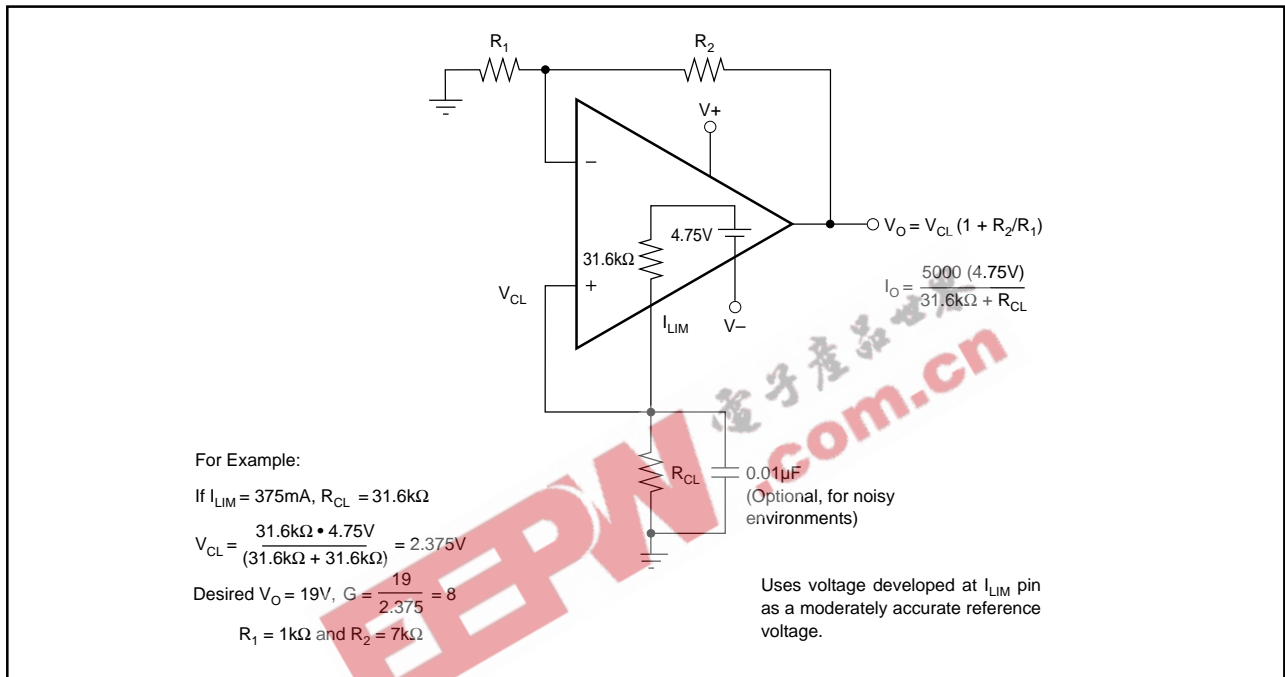

FIGURE 12. Voltage Source.

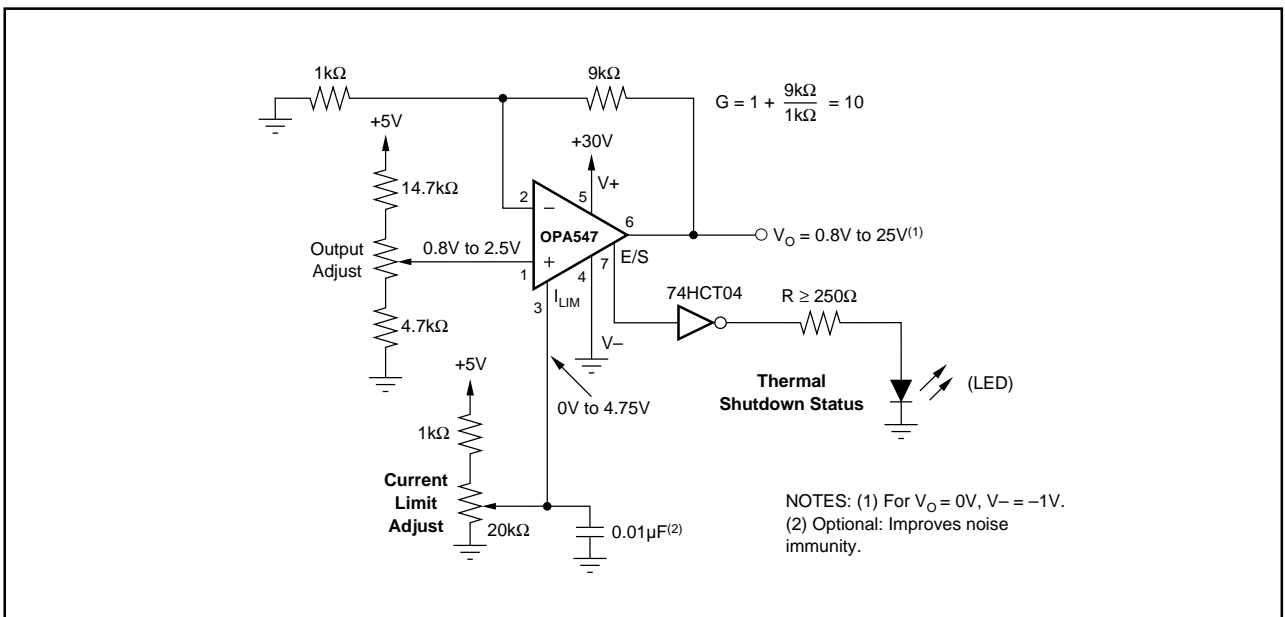

FIGURE 13. Resistor-Controlled Programmable Power Supply.

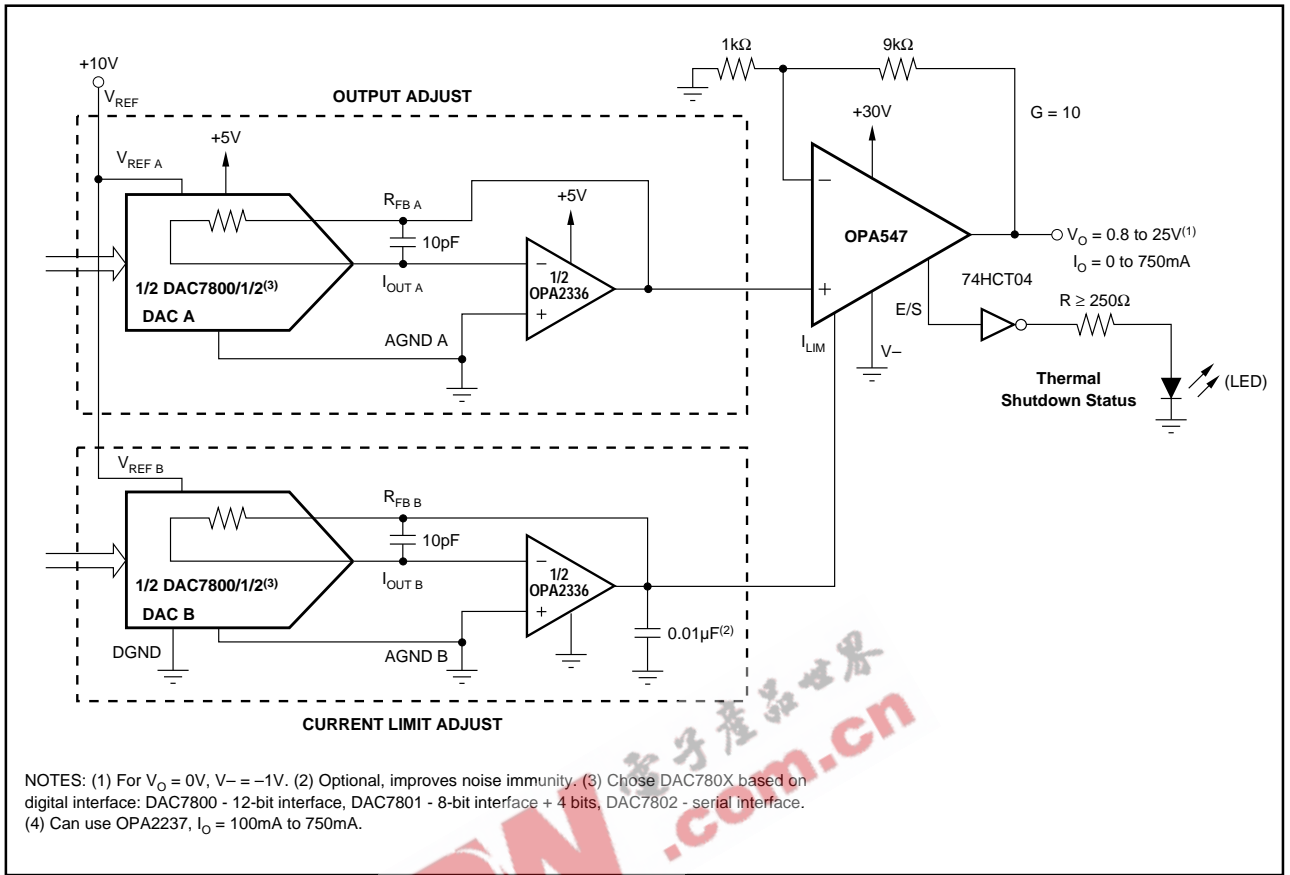

FIGURE 14. Digitally-Controlled Programmable Power Supply.

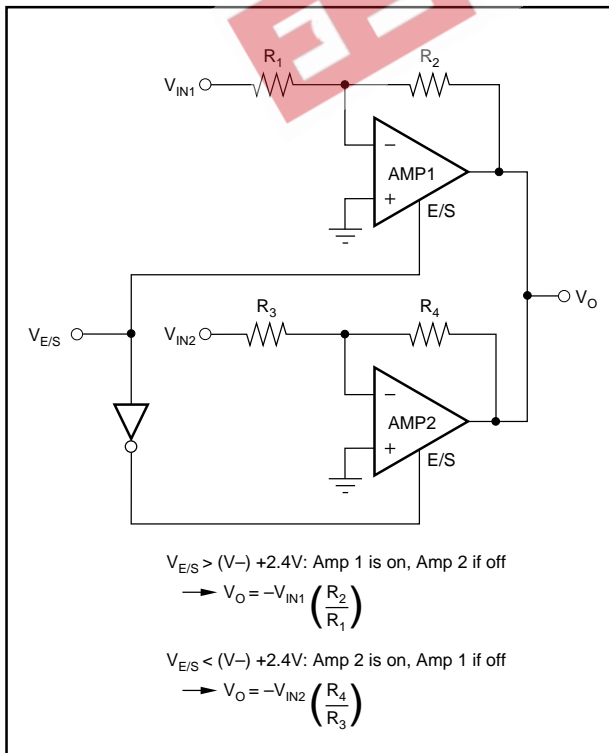

FIGURE 15. Swap Amplifier.

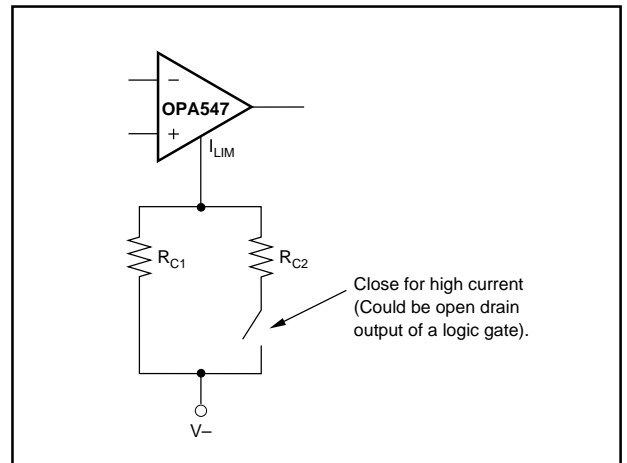

FIGURE 16. Multiple Current Limit Values.