

InAs photovoltaic detector P10090 series

Low noise, high reliability infrared detectors (for 3 μm band)

InAs photovoltaic detectors have high sensitivity in the infrared region around 3 μm as with PbS photoconductive detectors, and also feature low noise and high reliability. P10090 series is a new family of InAs photovoltaic detectors that deliver even higher sensitivity than our conventional products (P8079 series).

Features

- Low noise
- High reliability
- High detectivity (D*)
- Available in multi-element arrays (custom product)

Applications

- Gas analysis
- Laser detection
- Infrared spectrophotometry
- Radiation thermometer

Accessories (Optional)

- Heatsink for one-stage TE-cooled type A3179
- Heatsink for two-stage TE-cooled type A3179-01
- Temperature controller C1103-04
- Infrared detector module with preamp P4631-01
- Amplifiers for InAs photovoltaic detector (custom-made product)

■ Specifications/Absolute maximum ratings

Type No.	Dimensional outline/ Window material *	Package	Cooling	Active area (mm)	Absolute maximum ratings			
					Thermistor power dissipation (mW)	Reverse voltage VR (V)	Operating temperature Topr (°C)	Storage temperature Tstg (°C)
P10090-01	①/S	TO-5	Non-cooled	φ1	-	0.5	-40 to +60	-40 to +80
P10090-11	②/S	TO-8	One-stage TE-cooled		0.2			
P10090-21			Two-stage TE-cooled					

* Window material S: sapphire glass

■ Electrical and optical characteristics (Typ. unless otherwise noted)

Type No.	Measurement condition Element temperature T (°C)	Peak sensitivity wavelength λp (μm)	Cut-off wavelength λc (μm)	Photo sensitivity S λ=λp (A/W)	Shunt resistance Rsh		D* (λp, 600, 1)		NEP λ=λp (W/Hz ^{1/2})	Rise time tr VR=0 V RL=50 Ω 0 to 63 % (μs)
					Min. (Ω)	Typ. (Ω)	Min. (cm·Hz ^{1/2} /W)	Typ. (cm·Hz ^{1/2} /W)		
	P10090-01	25	3.35	3.65	1.0	40	70	3.0 × 10 ⁹	4.5 × 10 ⁹	1.5 × 10 ⁻¹¹
P10090-11	-10	3.30	3.55	1.2	250	400	1.0 × 10 ¹⁰	1.6 × 10 ¹⁰	5.3 × 10 ⁻¹²	0.45
P10090-21	-30	3.25	3.45		1000	1300	2.0 × 10 ¹⁰	3.2 × 10 ¹⁰	2.8 × 10 ⁻¹²	0.30

■ Spectral response (D^*)

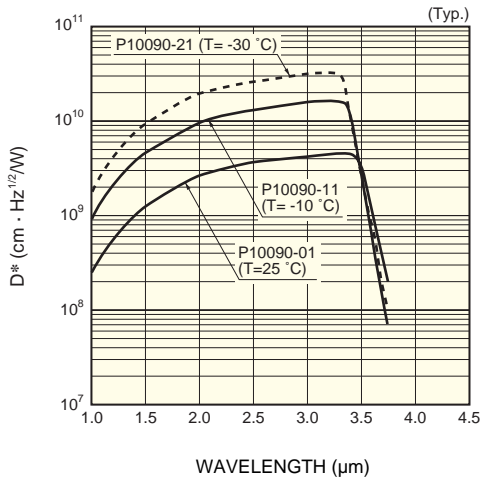

■ Spectral response

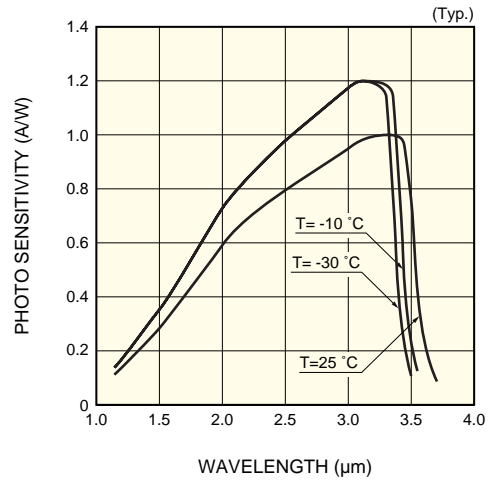

■ Dark current vs. reverse voltage

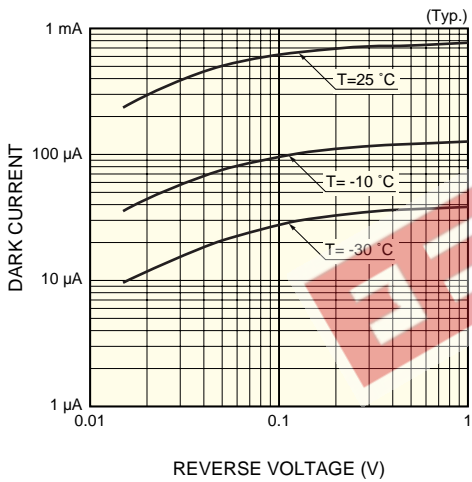

■ Shunt resistance vs. element temperature

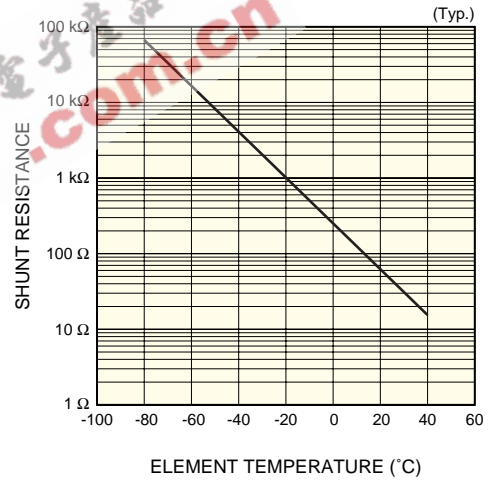

■ Linearity

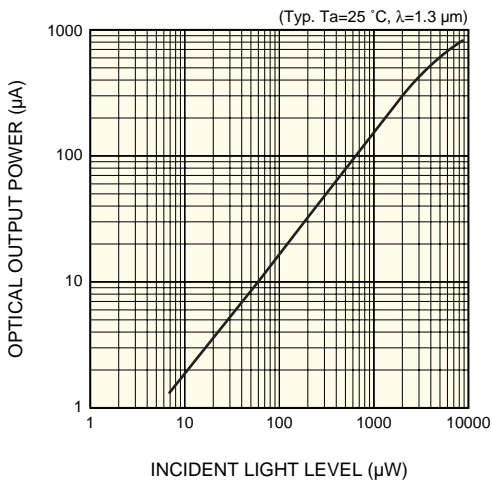

■ Sensitivity uniformity

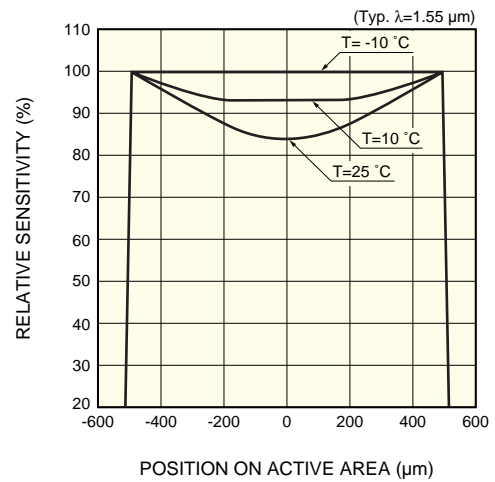

Current vs. voltage of TE-cooled type

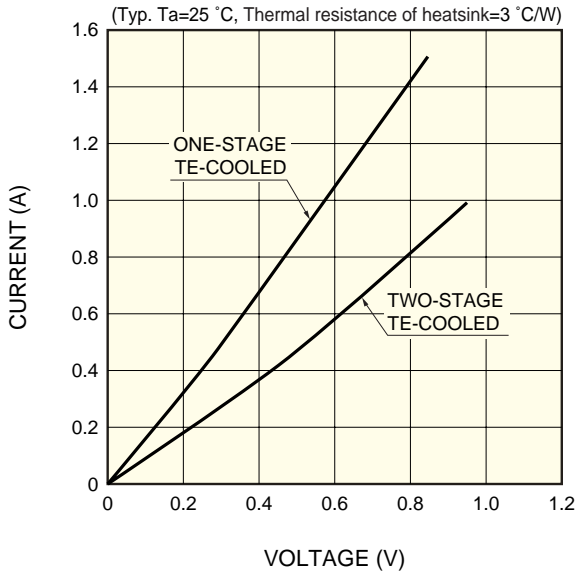

KIRDB0115EB

Cooling characteristics of TE-cooled type

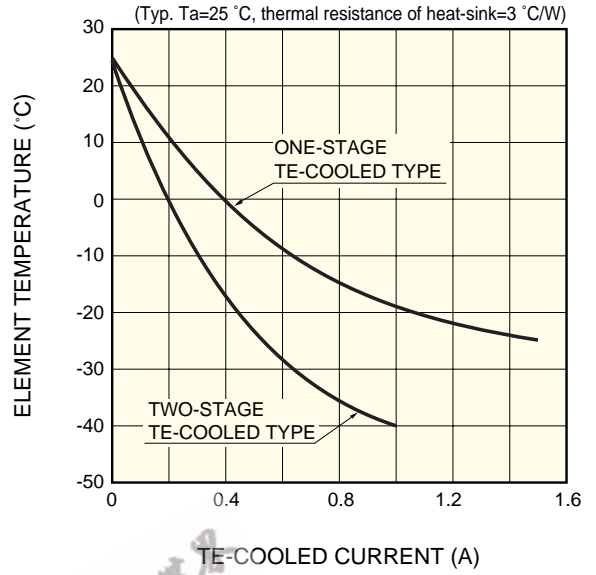

KIRDB0181EA

Thermistor temperature characteristic

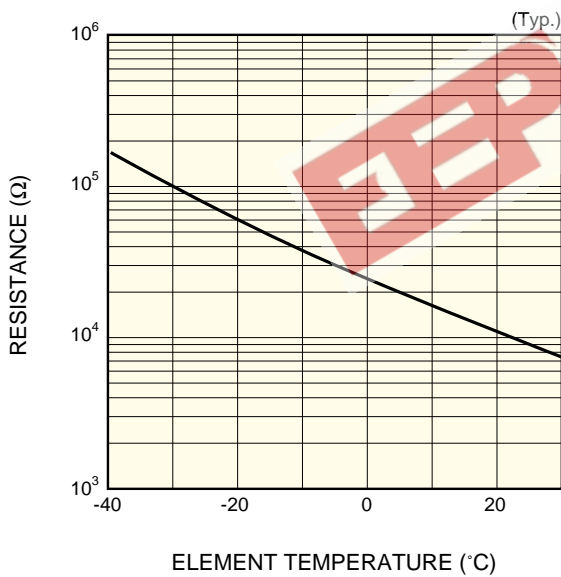

KIRDB0116EA

Measurement circuit

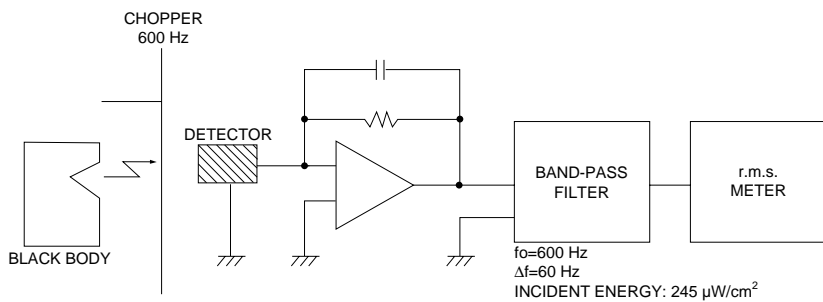

KIRDC0075EA

InAs photovoltaic detector P10090 series

Dimensional outlines (unit: mm)

① P10090-01

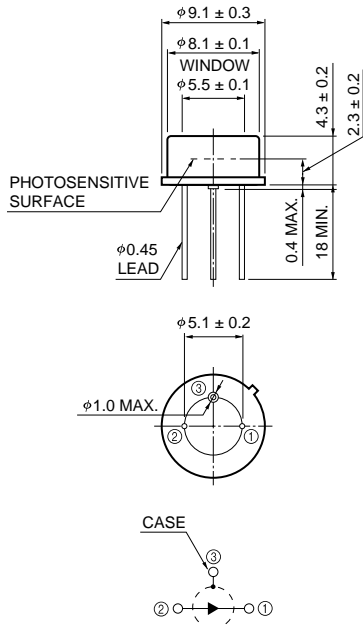

② P10090-11/-21

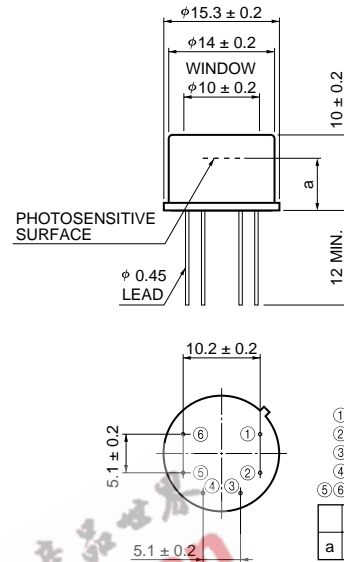

- ① DETECTOR (ANODE)
- ② DETECTOR (CATHODE)
- ③ TE-COOLER (-)
- ④ TE-COOLER (+)
- ⑤⑥ THERMISTOR

	P10090-11	P10090-21
a	4.5 ± 0.2	6.9 ± 0.2

KIRDA0119EA

KIRDA0191EA

HAMAMATSU

Information furnished by HAMAMATSU is believed to be reliable. However, no responsibility is assumed for possible inaccuracies or omissions. Specifications are subject to change without notice. No patent rights are granted to any of the circuits described herein. ©2007 Hamamatsu Photonics K.K.

HAMAMATSU PHOTONICS K.K., Solid State Division

1126-1 Ichino-cho, Higashi-ku, Hamamatsu City, 435-8558 Japan, Telephone: (81) 53-434-3311, Fax: (81) 53-434-5184, www.hamamatsu.com

U.S.A.: Hamamatsu Corporation, 360 Foothill Road, P.O.Box 6910, Bridgewater, N.J. 08807-0910, U.S.A., Telephone: (1) 908-231-0960, Fax: (1) 908-231-1218

Germany: Hamamatsu Photonics Deutschland GmbH, Arzbergerstr. 10, D-82211 Herrsching am Ammersee, Germany, Telephone: (49) 08152-3750, Fax: (49) 08152-2658

France: Hamamatsu Photonics France S.A.R.L.: 19, Rue du Saule Trapu, Parc du Moulin de Massy, 91882 Massy Cedex, France, Telephone: 33-(1) 69 53 71 00, Fax: 33-(1) 69 53 71 10

United Kingdom: Hamamatsu Photonics UK Limited, 2 Howard Court, 10 Tewin Road, Welwyn Garden City, Hertfordshire AL7 1BW, United Kingdom, Telephone: (44) 1707-294888, Fax: (44) 1707-325777

North Europe: Hamamatsu Photonics Norden AB, Smidesvägen 12, SE-171 41 Solna, Sweden, Telephone: (46) 8-509-031-00, Fax: (46) 8-509-031-01

Italy: Hamamatsu Photonics Italia S.R.L.: Strada della Moia, 1/E, 20020 Arese, (Milano), Italy, Telephone: (39) 02-935-81-733, Fax: (39) 02-935-81-741

Cat. No. KIRD1099E03
Mar. 2007 DN