

MCT photoconductive detector P3257 series, P4249-08

10 μm band infrared detector with high sensitivity and high-speed response



Features

- High-speed response, high sensitivity in the 10 μm band detection
- Photoconductive element that decreases its resistance by input of infrared light
- Custom devices available
Custom devices not listed in this catalog are also available with different spectral response, active area sizes and number of element.
- Wide product lineups including non-cooled type, thermoelectrically cooled type and micro-cooled type
Easy-to-use infrared detector modules with preamp available.

Applications

- Thermal imaging
- Remote sensing
- FTIR
- CO₂ laser detection
- Infrared spectrophotometer

Accessories (Optional)

- Valve operator A3515
- Amplifiers for dewar type MCT photoconductive detector C5185
- Infrared detector module with preamp P7752-10 (with P3257-10)

■ Specification / Absolute maximum ratings

Type No.	Dimensional outline/ Window material	Package	Cooling	Active area (mm)	Absolute maximum ratings		
					Allowable current (mA)	Operating temperature T _{opr} (°C)	Storage temperature T _{stg} (°C)
P3257-25	①/ZnS	Metal dewar	Liquid nitrogen	0.025 × 0.025	10	-40 to +60	-55 to +60
P3257-01				0.1 × 0.1	20		
P3257-10				1 × 1	40		
P4249-08	②/ZnS			0.5 × 0.5 *1	30		

*1: 8 elements array

■ Electrical and optical characteristics (Typ. unless otherwise noted)

Type No.	Measurement condition	Peak sensitivity wavelength λ _p	Cut-off wavelength λ _c	Photo sensitivity *2 S λ=λ _p	D* (500, 1200, 1)		D* (λ _p , 1200, 1)	Rise time t _r 0 to 63 %	Dark resistance R _d
	Element temperature T				Min.	Typ.			
	(°C)	(μm)	(μm)	(V/W)	(cm·Hz ^{1/2} /W)	(cm·Hz ^{1/2} /W)	(cm·Hz ^{1/2} /W)	(μs)	(Ω)
P3257-25	-196	10.0	12.0	1 × 10 ⁵	1 × 10 ¹⁰	2 × 10 ¹⁰	4.0 × 10 ¹⁰	0.6	40
P3257-01				3 × 10 ⁴					80
P3257-10				1 × 10 ³					40
P4249-08				2 × 10 ³					

*2: Photo sensitivity changes with the bias current. The values in the above table are measured with the optimum bias current.

MCT photoconductive detector P3257 series, P4249-08

Spectral response

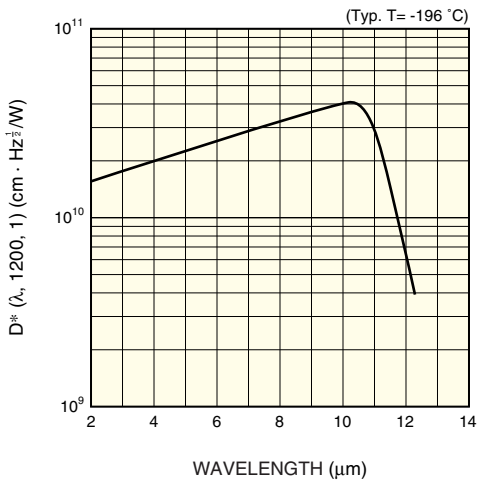

Spectral response can be shifted upon request.

S/N vs. bias current (P3257-10)

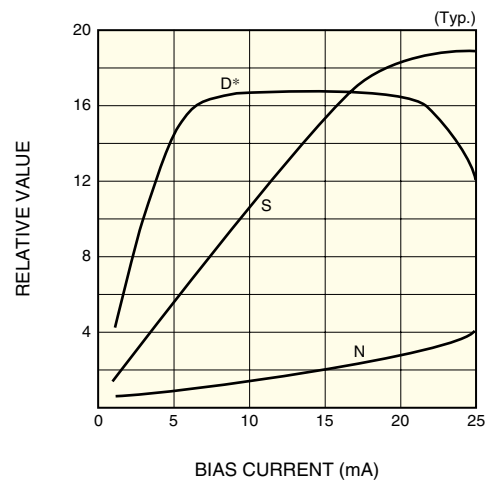

The detector must be operated in a range where the D* becomes Max.

Noise frequency characteristic

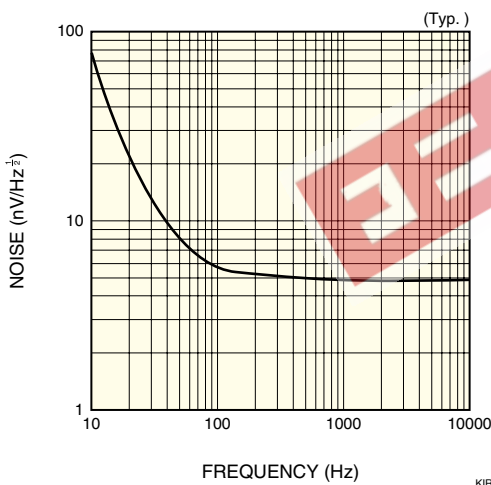

■ **Multi-element active area (P4249-08, unit: μm)**
MCT detectors of custom-designed multi-element arrays are also available on request. For the number of elements, element size and packaging, please consult us with your specific needs.

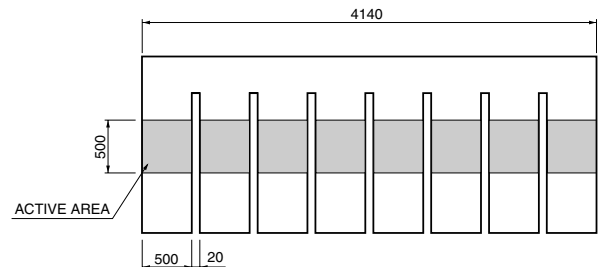

Measurement circuit

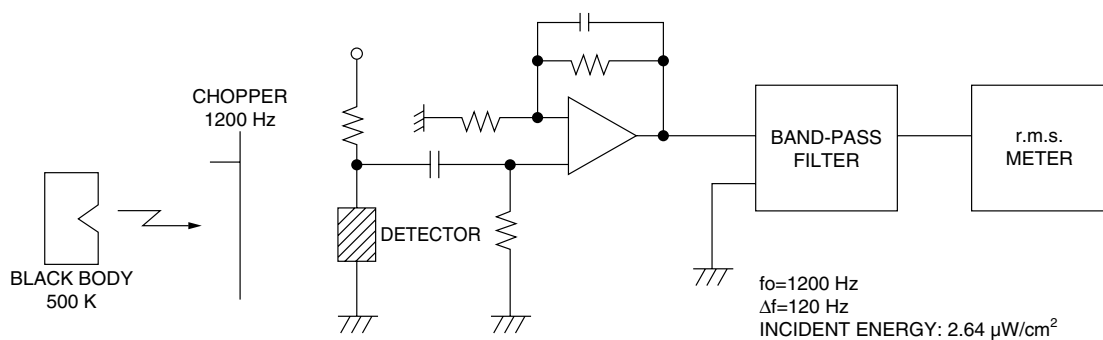

KIRDC0007EA

MCT photoconductive detector P3257 series, P4249-08

Dimensional outlines (unit: mm)

① P3257-25/-01/-10

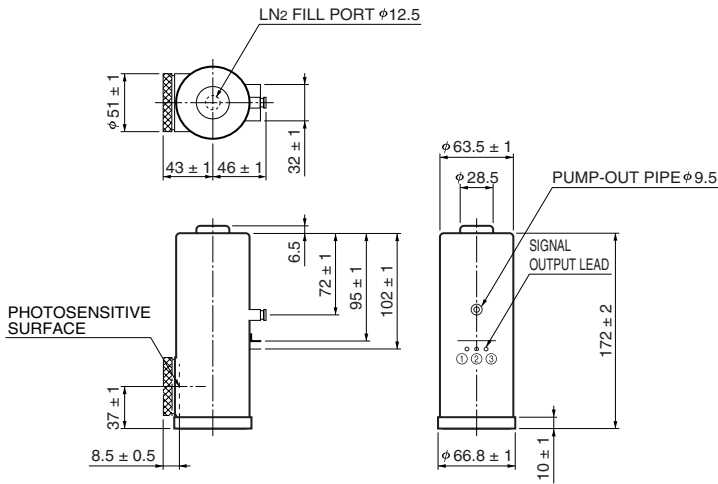

- ① DETECTOR
- ② NC
- ③ DETECTOR

② P4249-08

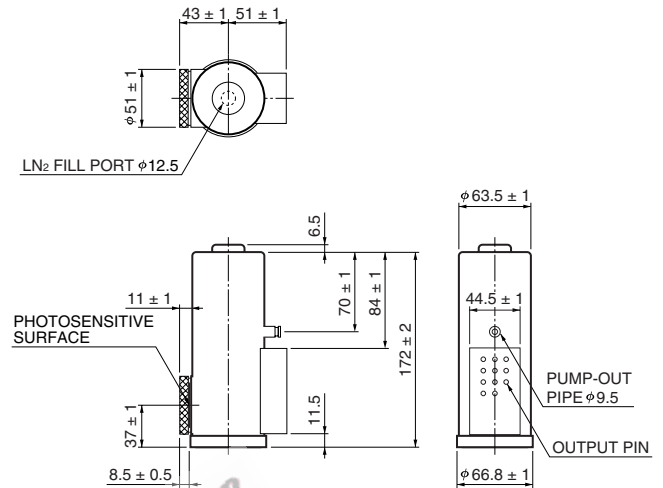

PIN ARRANGEMENT



- ① NC
- ② CH8
- ③ CH7
- ④ CH6
- ⑤ CH5
- ⑥ CH4
- ⑦ CH3
- ⑧ CH2
- ⑨ CH1
- ⑩ NC
- ⑪ COM

KIRDA0131EC

KIRDA0135EA

HAMAMATSU

Information furnished by HAMAMATSU is believed to be reliable. However, no responsibility is assumed for possible inaccuracies or omissions. Specifications are subject to change without notice. No patent rights are granted to any of the circuits described herein. ©2003 Hamamatsu Photonics K.K.

HAMAMATSU PHOTONICS K.K., Solid State Division

1126-1 Ichino-cho, Hamamatsu City, 435-8558 Japan, Telephone: (81) 053-434-3311, Fax: (81) 053-434-5184, <http://www.hamamatsu.com>

U.S.A.: Hamamatsu Corporation: 360 Foothill Road, P.O.Box 6910, Bridgewater, N.J. 08807-0910, U.S.A., Telephone: (1) 908-231-0960, Fax: (1) 908-231-1218

Germany: Hamamatsu Photonics Deutschland GmbH: Arzbergerstr. 10, D-82211 Herrsching am Ammersee, Germany, Telephone: (49) 08152-3750, Fax: (49) 08152-2658

France: Hamamatsu Photonics France S.A.R.L.: 8, Rue du Saule Trapu, Parc du Moulin de Massy, 91882 Massy Cedex, France, Telephone: 33-(1) 69 53 71 00, Fax: 33-(1) 69 53 71 10

United Kingdom: Hamamatsu Photonics UK Limited: 2 Howard Court, 10 Tewin Road, Welwyn Garden City, Hertfordshire AL7 1BW, United Kingdom, Telephone: (44) 1707-294888, Fax: (44) 1707-325777

North Europe: Hamamatsu Photonics Norden AB: Smidesvägen 12, SE-171 41 Solna, Sweden, Telephone: (46) 8-509-031-00, Fax: (46) 8-509-031-01

Italy: Hamamatsu Photonics Italia S.R.L.: Strada della Moia, 1/E, 20020 Arese, (Milano), Italy, Telephone: (39) 02-935-81-733, Fax: (39) 02-935-81-741

Cat. No. KIRD1023E04
Feb. 2003 DN