

Infrared detector module with preamp Thermoelectrically cooled type

Easy-to-use detector module with built-in preamp



Infrared detector modules operate just by connecting to a DC power supply. The detector element is selectable from among InGaAs, PbS, PbSe, MCT, InAs and InSb, which are all combined with a thermoelectric cooler. P4631-10 using an MCT detector is especially suited for CO₂ laser detection. We welcome requests for custom devices that suit your application.

Features

- High S/N
- Compact size
- Easy to use
Operates just by connecting to DC power supply
- Circuit design optimized for detector element characteristics
- Built-in thermoelectric cooling control circuit (fixed control temperature)

Applications

- Infrared detection
- CO₂ laser detection

Accessories (Supplied)

- DC power cable (2 m): A4372-03
When using a power supply other than Hamamatsu C3871-03/-04 power supplies designed for IR detector modules, use a mating connector (Hirose Electric RM12BRD-6S).
- Instruction manual

DC power supply (Optional)

- Power supply for module (±15 V, +2.5 V) C3871-03
- Power supply for module (±15 V, +4.5 V) C3871-04 (designed for P4631-03/-04)

Specifications / Absolute maximum ratings

Type No.	Detector element	Active area (mm)	Rated input voltage (V)		Absolute maximum ratings							
					Input voltage (V)	Operating temperature T _{opr} (°C)	Storage temperature T _{stg} (°C)					
G6122	InGaAs	φ1	±15 ± 0.5	+2.5 ⁺¹ _{-0.05}	V _{p1} =+5	0 to +40	-20 to +50					
G6122-03		φ1										
G6126		φ5										
P4638		4 × 5										
P4639	3 × 3											
P4631	MCT	1 × 1						±4.5 ± 0.25	V _c =±18	V _{p2} =+7		
P4631-01	InAs	φ1										
P4631-03	InSb	1 × 1										
P4631-04	MCT	1 × 1										
P4631-10												

Electrical and optical characteristics (Typ. T_a=25 °C)

Type No.	Detector element temperature at rated input T (°C)	Peak sensitivity wavelength λ _p (μm)	Cut-off wavelength λ _c (μm)	Photo sensitivity S λ=λ _p (V/W)	NEP λ=λ _p (W/Hz ^{1/2})	Frequency response -3 dB (Hz)	Output impedance (Ω)	Maximum output voltage V _{RL} =1 kΩ (V)	Maximum current consumption *2 (mA)		
									+V _c , -V _c	V _{p1} or V _{p2}	
G6122	-15	1.95	2.05	1.7 × 10 ⁸	1 × 10 ⁻¹³	DC to 2.2 k	50	+10	+60, -30	+1100	
G6122-03		2.3	2.56	1.5 × 10 ⁸	6 × 10 ⁻¹³	DC to 3 k		+10	+60, -30	+1100	
G6126		1.55	1.66	5 × 10 ⁷	7 × 10 ⁻¹⁴	DC to 1.2 k		+10	+50, -30	+1100	
P4638		2.5	3.2	3 × 10 ⁷	8 × 10 ⁻¹³	0.2 to 300		±10	+50, -20	+1100	
P4639	-25	4.2	5.2	2 × 10 ⁵	1 × 10 ⁻¹⁰	0.2 to 10 k	50	±10	+50, -20	+1100	
P4631		3.6	4.3	2 × 10 ⁷	1 × 10 ⁻¹²	5 to 20 k		±2.5	+60, -10	+1100	
P4631-01	-28	3.25	3.5	1 × 10 ⁷	6 × 10 ⁻¹²	5 to 300 k	50	±8	+60, -10	+1100	
P4631-03	-58	5.5	6.3	1.5 × 10 ⁵	1.5 × 10 ⁻¹¹	DC to 100 k		+10	+90, -30	+1100	
P4631-04		4.8	5.5	1 × 10 ⁷	5 × 10 ⁻¹²	5 to 35 k		±5	+80, -10	+1100	
P4631-10		-3	6.5	11.5	2 *1	2.5 × 10 ⁻⁶ *1		DC to 500 k	+10	+150, -30	+1400

*1: λ=10.6 μm

*2: V_c=15 V, V_{p1}=2.5 V or V_{p2}=4.5 V

Infrared detector module with preamp **Thermoelectrically cooled type**

■ Spectral response

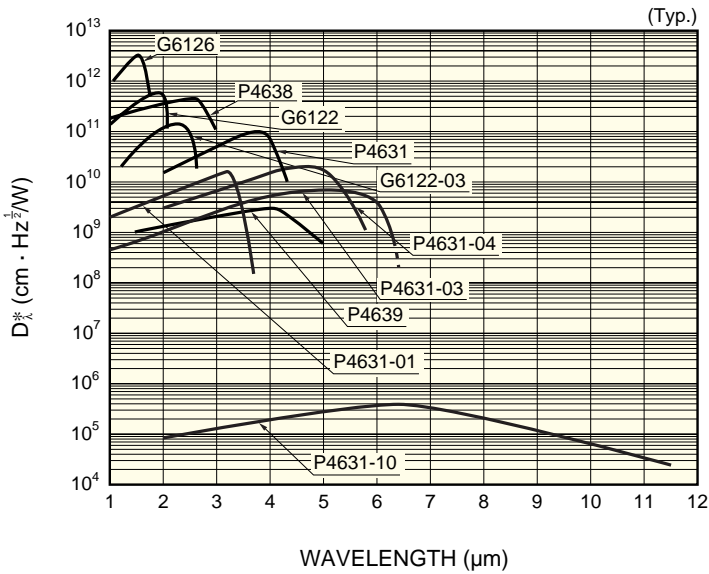

KIRDB0188EB

■ Dimensional outlines (unit: mm)

G6122/-03, G6126, P4638, P4639, P4631/-01

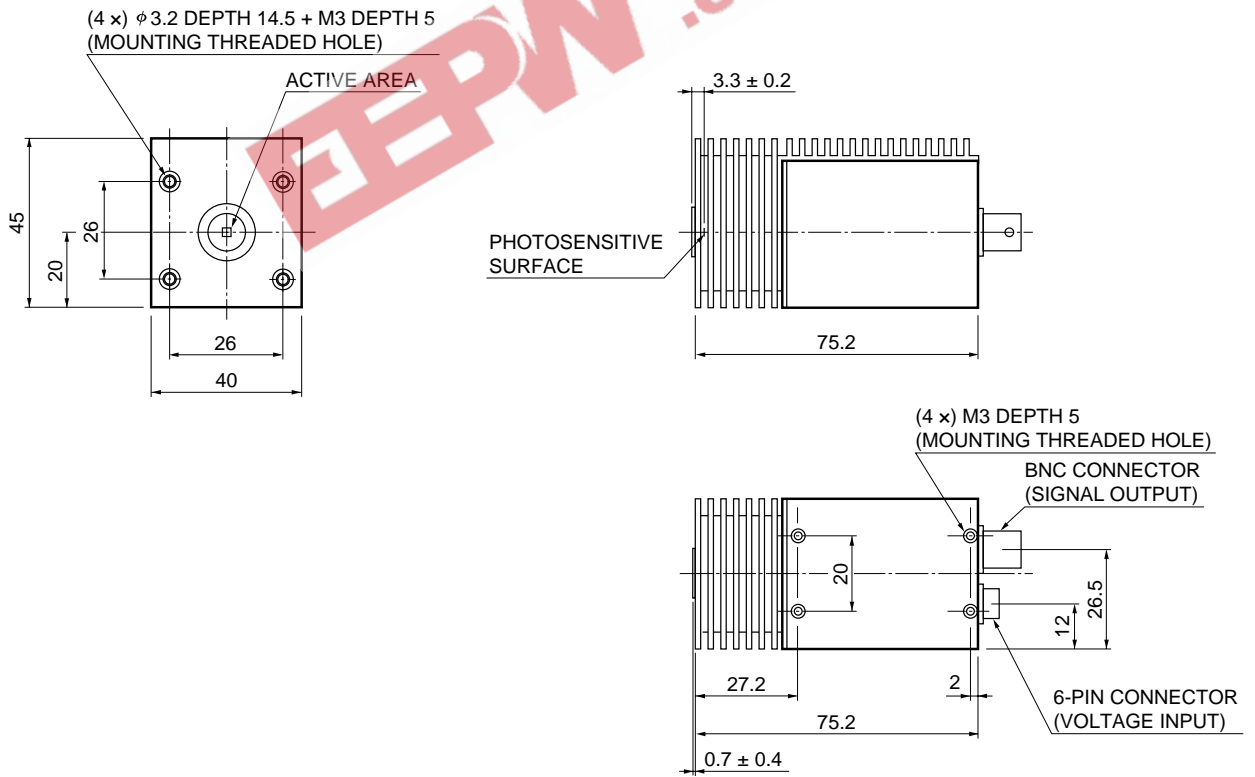

KIRDA0009EE

Infrared detector module with preamp Thermoelectrically cooled type

(unit: mm)

P4631-03

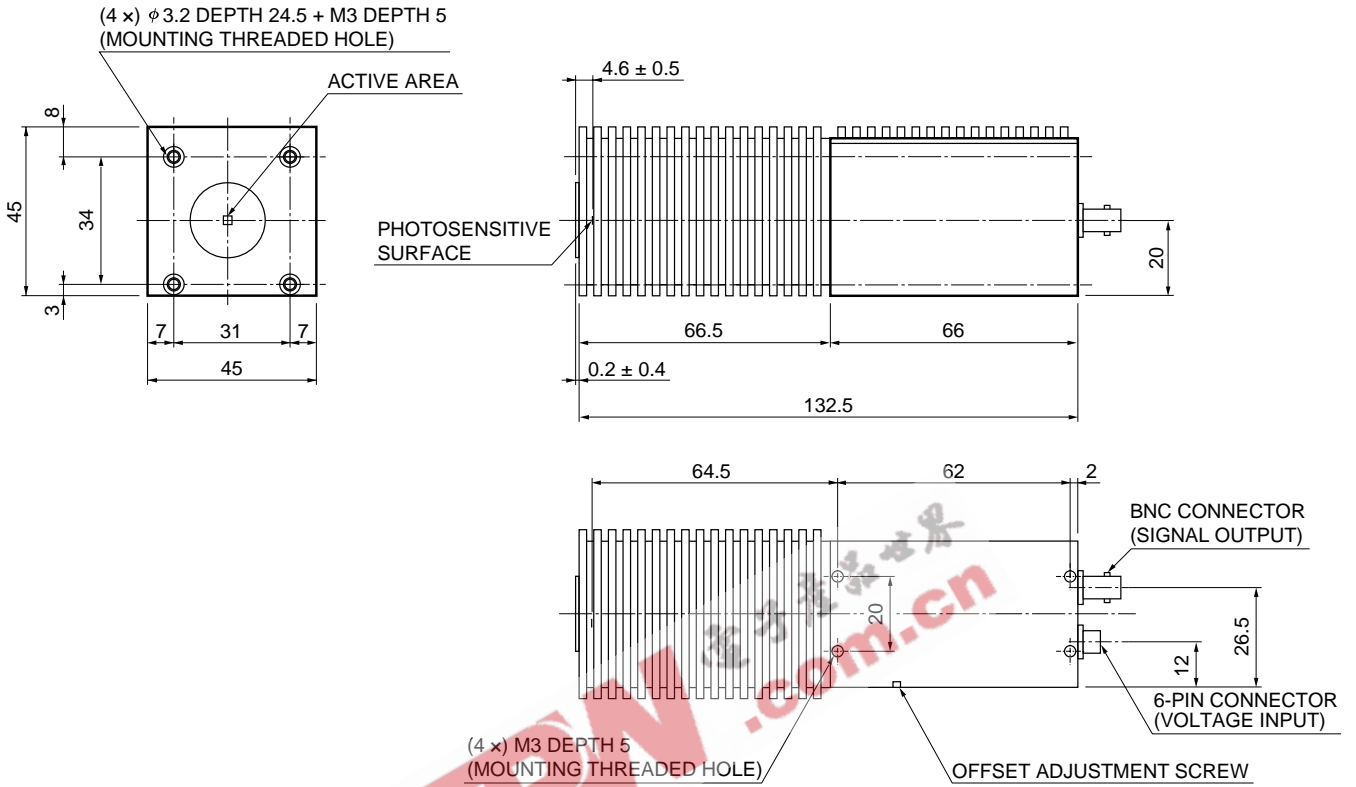

KIRDA0137EC

P4631-04

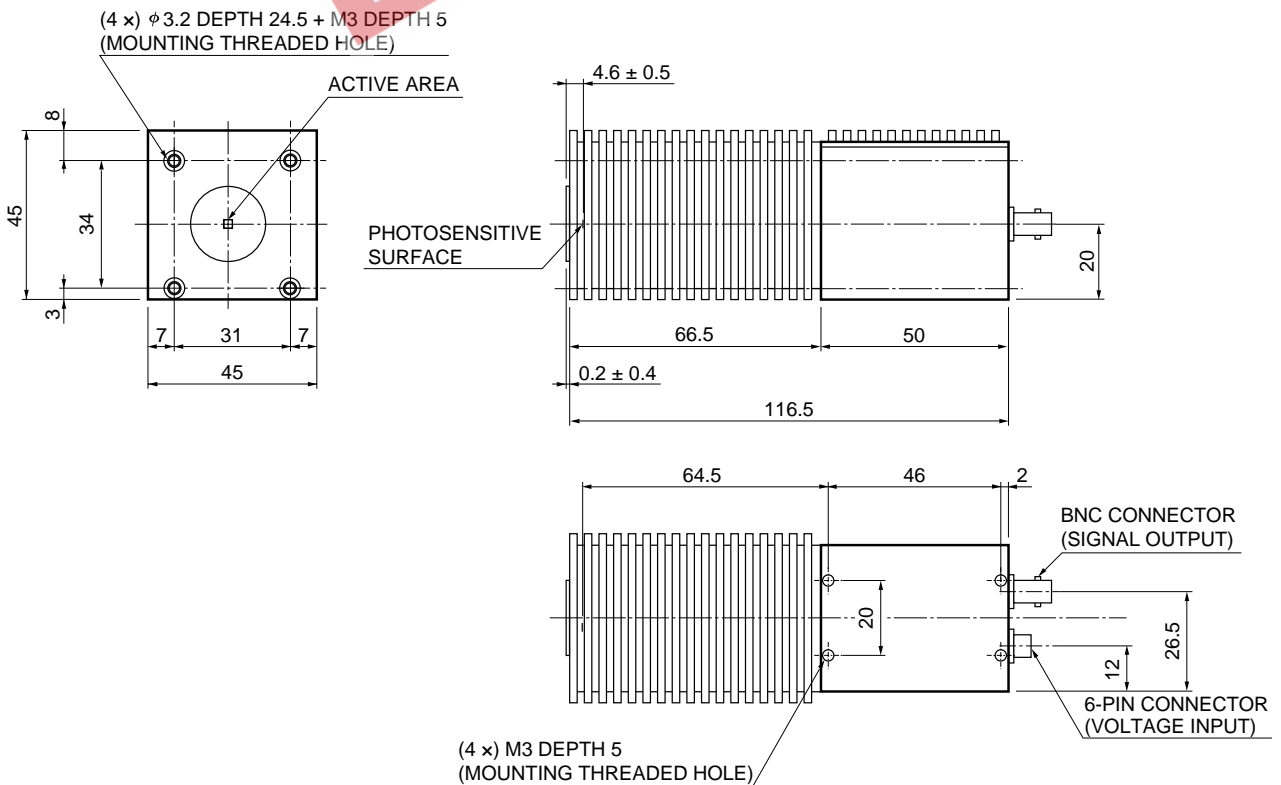

KIRDA0138EC

Infrared detector module with preamp Thermoelectrically cooled type

(unit: mm)

P4631-10

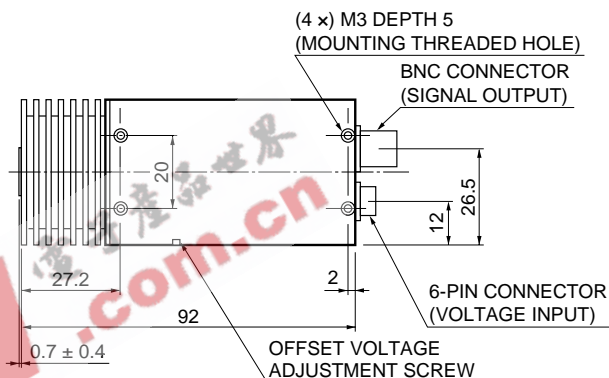
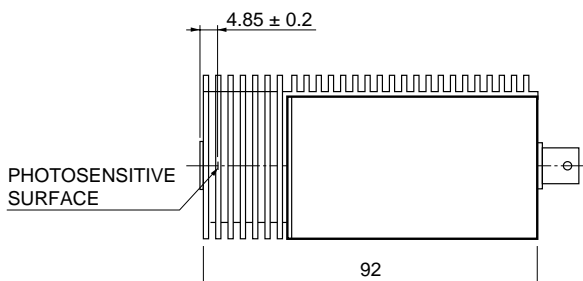
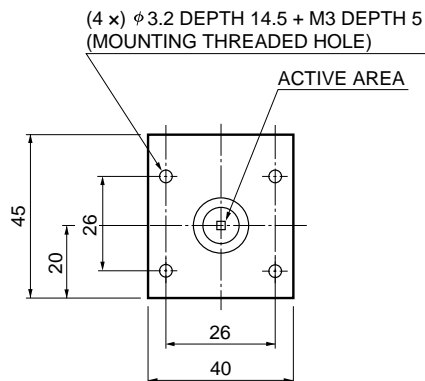

KIRDA0139EC

Handling precaution

The infrared detector modules (TE-cooled type) do not operate if not cooled. Always supply +2.5 V or +4.5 V to cool the detector element.

HAMAMATSU

Information furnished by HAMAMATSU is believed to be reliable. However, no responsibility is assumed for possible inaccuracies or omissions. Specifications are subject to change without notice. No patent rights are granted to any of the circuits described herein. ©2003 Hamamatsu Photonics K.K.

HAMAMATSU PHOTONICS K.K., Solid State Division

1126-1 Ichino-cho, Hamamatsu City, 435-8558 Japan, Telephone: (81) 053-434-3311, Fax: (81) 053-434-5184, <http://www.hamamatsu.com>

U.S.A.: Hamamatsu Corporation: 360 Foothill Road, P.O.Box 6910, Bridgewater, N.J. 08807-0910, U.S.A., Telephone: (1) 908-231-0960, Fax: (1) 908-231-1218

Germany: Hamamatsu Photonics Deutschland GmbH: Arzbergerstr. 10, D-82211 Herrsching am Ammersee, Germany, Telephone: (49) 08152-3750, Fax: (49) 08152-2658

France: Hamamatsu Photonics France S.A.R.L.: 8, Rue du Saule Trapu, Parc du Moulin de Massy, 91882 Massy Cedex, France, Telephone: 33-(1) 69 53 71 00, Fax: 33-(1) 69 53 71 10

United Kingdom: Hamamatsu Photonics UK Limited: 2 Howard Court, 10 Tewin Road, Welwyn Garden City, Hertfordshire AL7 1BW, United Kingdom, Telephone: (44) 1707-294888, Fax: (44) 1707-325777

North Europe: Hamamatsu Photonics Norden AB: Smidesvägen 12, SE-171 41 Solna, Sweden, Telephone: (46) 8-509-031-00, Fax: (46) 8-509-031-01

Italy: Hamamatsu Photonics Italia S.R.L.: Strada della Moia, 1/E, 20020 Arese, (Milano), Italy, Telephone: (39) 02-935-81-733, Fax: (39) 02-935-81-741

Cat. No. KIRD1036E06
Aug. 2003 DN