

Programmable Attenuators

P-AT Series



■Features

- 1. Used for frequencies from DC to 26.5GHz (max.)**
Input/output couplings utilizes Hirose's HE* connector, which is combination of the internal attenuation elements, provides the required attenuation characteristic.
- 2. Self-disconnecting**
The drive current will automatically switch off after setting the attenuation.
- 3. Automatic return**
In the event of sudden shock the attenuation will quickly return to the pre-set level.

■Applications

Wide variety of measuring instruments and other devices requiring control of high frequency transmission lines.

- * HE connector will mate with K type connectors
- * K connector is a trademark of Anritsu Co.

■Product Specifications

Ratings	Frequency range	DC~8GHz(P-AT-6,AP-AT-7) DC~26.5GHz(P-AT-8)	Operating temperature range Operating relative humidity	-10°C to +75°C(No freezing) 95% Max.
---------	-----------------	---	--	---

Characteristic	Requirements	Conditions
1.Vibration	No electrical discontinuity of 1 μs or more	Frequency of 10 to 55 Hz, overall amplitude of 1.5 mm for 2 hours in each of 3 directions
2.Shock	No damage, cracks, or parts dislocation	Acceleration of 98 m/s ² , sine half-wave waveform, 3 cycles in each of the 3 axis
3.Temperature cycle	No damage, cracks, or parts dislocation	

●The test method conforms to MIL-STD-202.

■Materials and Finishes

Component	Material	Finish
Body	Aluminum	Conductive alumite
Coupling connector body	Stainless steel	Passivated
Female contact	Beryllium Copper	Gold plating

■Ordering Information

P-AT - 6 (8 - 70) A

① ② ③ ④ ⑤

① Series Name
② Suffix
③ Maximum frequency (GHz)
④ Maximum attenuation (dB)
⑤ Revised

Specifications

Part Number	Frequency Range (GHz)	V.S.W.R. (Max)	Attenuation (dB)	Attenuation Accuracy (dB)				Insertion Loss (dB) (Max)	Impedance (ohms)	Power (W)	Switching Volt (DC V)	Switching Current (Each Section) (mA)	Switching Time (ms)(Max)	Operating Life	Connectors	Weight (g)
				5dB	10dB	20dB	40dB									
P-AT-6(8-70)A	DC~8	1.35	0~70 (10dB STEP)	-	±0.5	±0.6	±1	1.5	50	1(CW)	+24	120+200×3 section	20	2×10 ⁶	HE-J	250
P-AT-7(8-75)A	DC~8	1.35	0~75 (5dB STEP)	±0.5	±0.5	±0.6	±1	1.5	50	1(CW)	+24	160+200×4 section	20	2×10 ⁶	HE-J	300
P-AT-8(26.5-70)A	DC~26.5	1.4 (DC~12GHz) 1.7 (12~26.5GHz)	0~70 (10dB STEP)	-	Ref table 1			0.55+0.06×f(GHz)	50	1(CW)	+24	120+200×3 section	20	2×10 ⁶	HE-J	240

Frequency Range (GHz)	Attenuation Accuracy(dB)						
	10dB	20dB	30dB	40dB	50dB	60dB	70dB
DC~8	±0.3	±0.5	±0.6	±0.7	±0.8	±1.0	±1.1
8~12	±0.4	±0.5	±0.7	±0.9	±1.0	±1.3	±1.5
12~20	±0.5	±0.6	±0.8	±1.1	±1.2	±1.4	±1.7
20~26.5	±0.7	±0.8	±1.0	±1.5	±1.6	±1.9	±2.3

Typical Data

P-AT-7(8-75)A

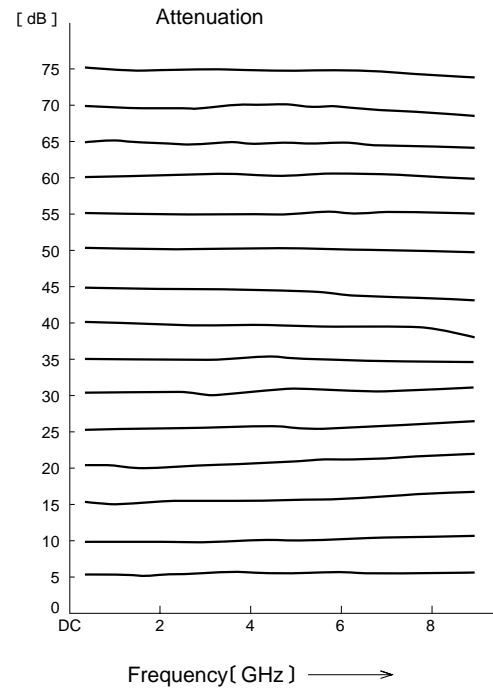
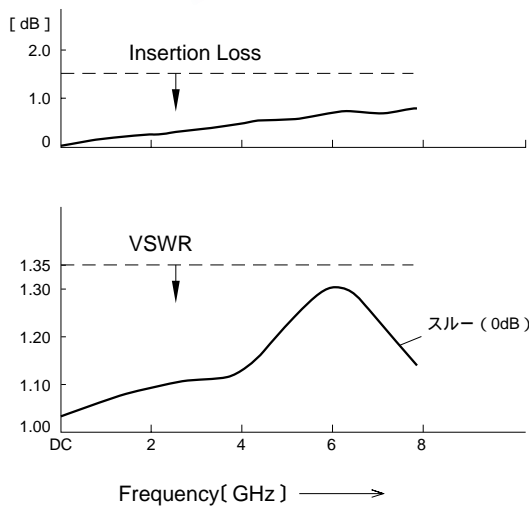

External Dimensions

P-AT-6(8-70)A

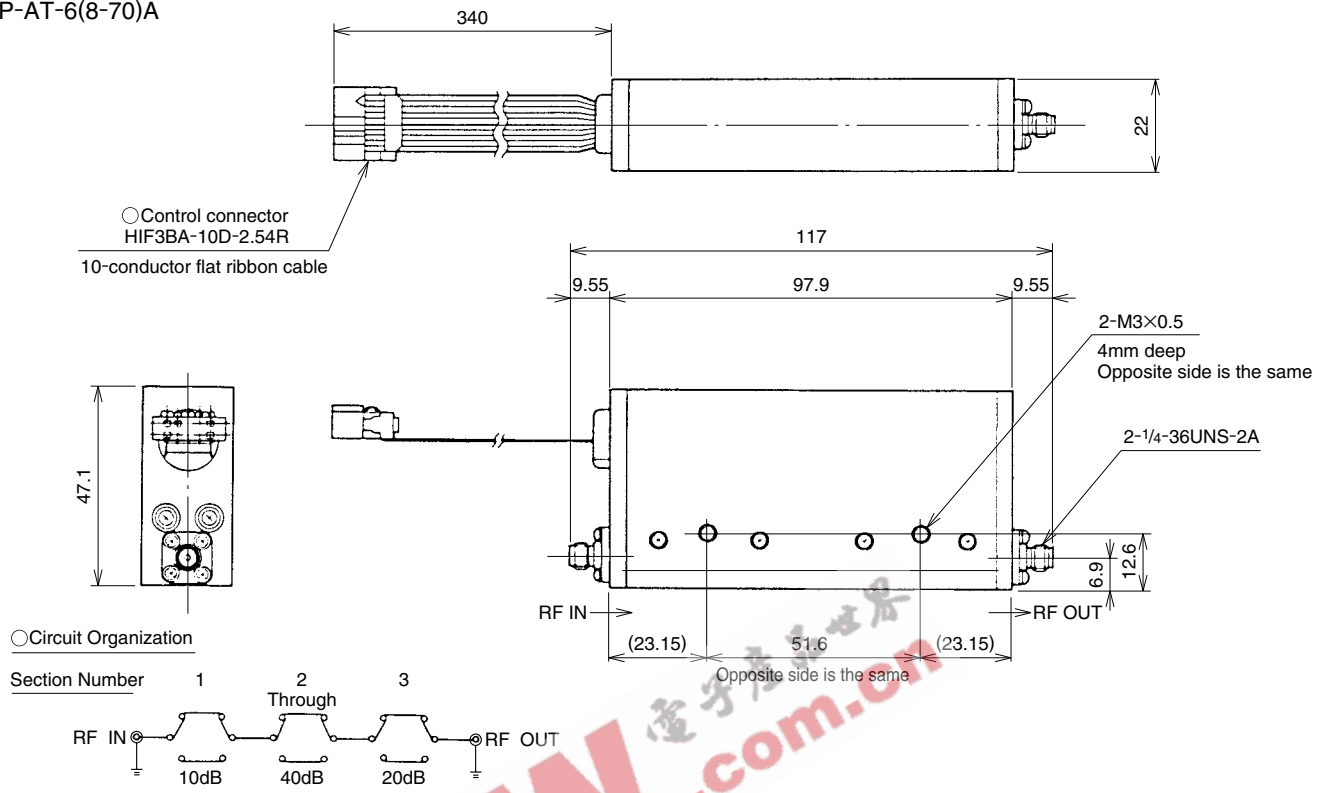

P-AT-7(8-75)A

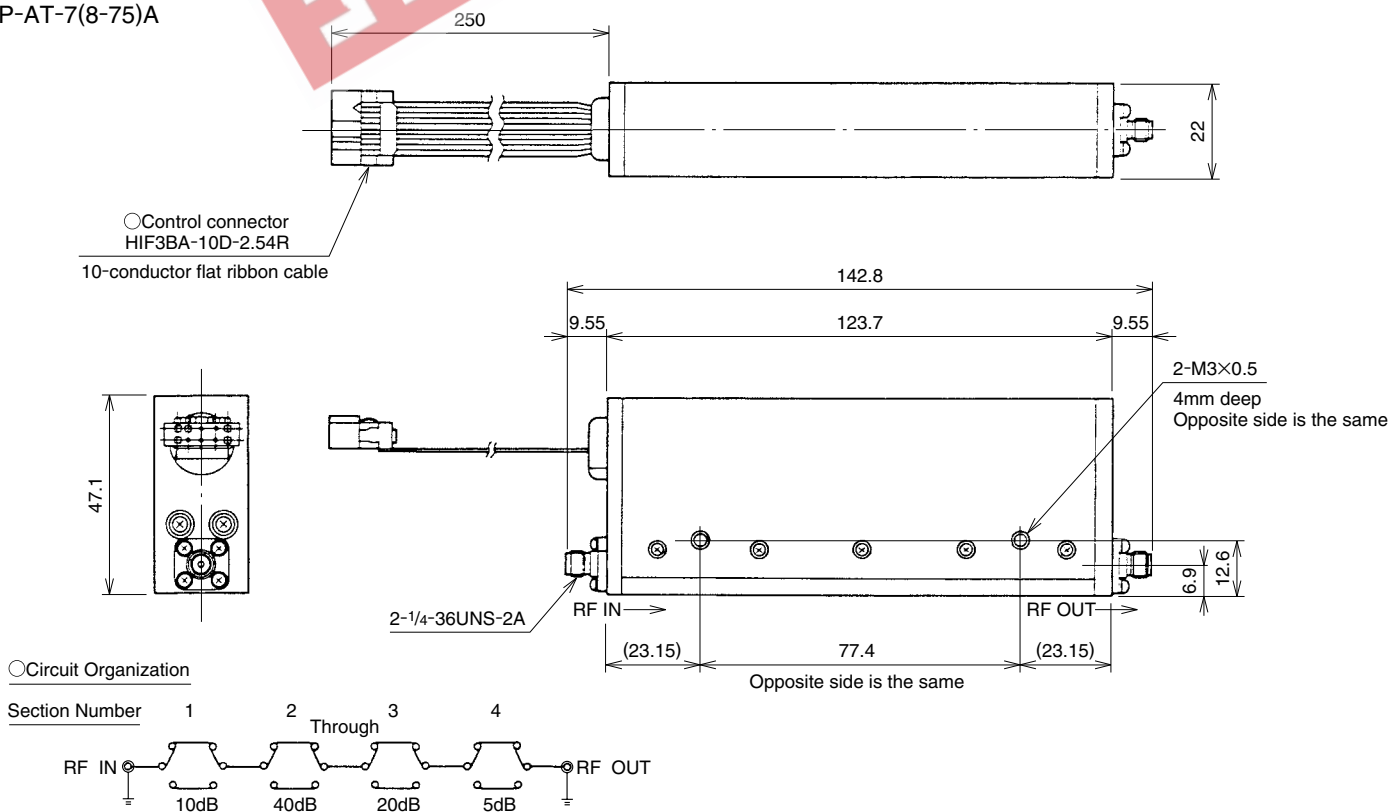

External Dimensions

P-AT-8(26.5-70)A

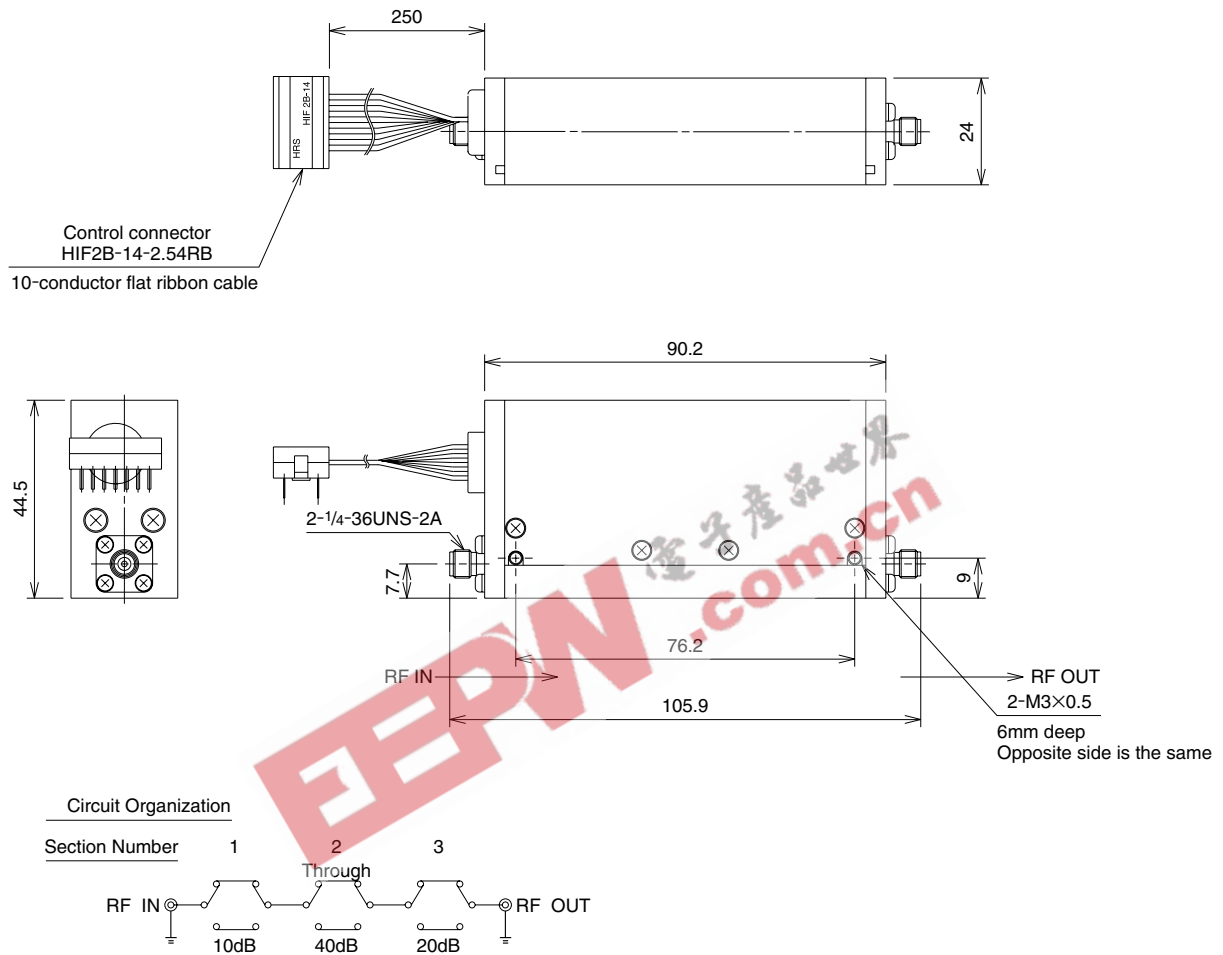

○HIF3BA-10D-2.54R Contact No.
P-AT-6(8-70)A,P-AT-7(8-75)A

○HIF2B-14-2.54RB Contact No.
P-AT-8(26.5-70)A

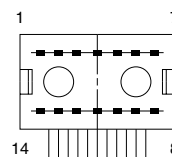
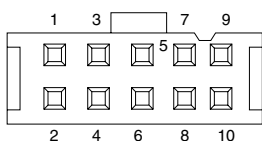

◆Attenuation Change Contact No.(Connect Ground)

Section No.	1			2			3			4		
	Contact No.	Cable Color	Attenuation	Contact No.	Cable Color	Attenuation	Contact No.	Cable Color	Attenuation	Contact No.	Cable Color	Attenuation
P-AT-6(8-70)A	1	Black	0dB(Through)	3	Gray	0dB(Through)	5	Blue	0dB(Through)	—	—	—
	2	White	10dB	4	Purple	40dB	6	Green	20dB	—	—	—
P-AT-7(8-75)A	1	Black	0dB(Through)	3	Gray	0dB(Through)	5	Blue	0dB(Through)	7	Yellow	0dB(Through)
	2	White	10dB	4	Purple	40dB	6	Green	20dB	8	Orange	5dB
P-AT-8(26.5-70)A	13	Black	0dB(Through)	3	Gray	0dB(Through)	11	Green	0dB(Through)	—	—	—
	2	White	10dB	9	Brown	40dB	5	Yellow	20dB	—	—	—

◆Drive Voltage Contact No.

Section No.	DC24V		Ground		Open	
	Contact No.	Cable Color	Contact No.	Cable Color	Contact No.	Cable Color
P-AT-6(8-70)A	9	Red	7	Yellow	—	—
	10	Brown	8	Orange	—	—
P-AT-7(8-75)A	9	Red	Connector Body	—	—	—
	10	Brown	—	—	—	—
P-AT-8(26.5-70)A	6	Red	12	Purple	4	Blue
	—	—	—	—	10	Orange
	—	—	—	—	1,7,8,14	—

○DC Drive Circuit (1 Section)

