

Single Channel OC-3c ATM and POS Physical Layer Device

FEATURES

- Single chip ATM and Packet over SONET/SDH Physical Layer Device operating at 155.52 Mbit/s.
- Implements the ATM Forum User Network Interface (UNI) and the ATM physical layer for Broadband ISDN according to CCITT Recommendation I.432.
- Implements Point-to-Point Protocol (PPP) over SONET/SDH according to RFC 2615.
- Processes duplex bit-serial 155.52 Mbit/s STS-3c/STM-1 data streams with on-chip clock and data recovery and clock synthesis.
- Complies with Bellcore GR-253-CORE (1995 Issue) jitter tolerance, jitter transfer and intrinsic jitter criteria.
- Provides control circuitry required to comply with Bellcore GR-253-CORE WAN clocking requirements related to wander transfer, holdover and long term stability when using an external VCXO.

- Provides a UTOPIA Level 2, 8-bit wide system interface (clocked up to 52 MHz) with parity support for ATM applications.
- Provides a UTOPIA Level 2, 16-bit wide system interface (clocked up to 52 MHz) with parity support for ATM applications.
- Provides a SATURN POS-PHY Level 2, 16-bit system interface (clocked up to 52 MHz) for Packet over SONET/SDH (POS) applications (similar to UTOPIA Level 2, but adapted for packet transfer).
- Provides support functions for 1+1 APS operation.

- Low power 2.5/3.3 V CMOS with 5 V TTL-compatible digital inputs/outputs (PECL inputs/outputs are 3.3 V and 5 V compatible).
- Industrial temperature range (-40°C to +85°C).
- 15 mm x15 mm 196 pin stPBGA package with 1 mm ball pitch.

APPLICATIONS

- Routers and Layer 3 Switches.
- 3G Wireless Base Station Controllers.
- DSLAM Uplinks.
- WAN and Edge ATM switches.
- LAN switches and hubs.
- Packet switches and hubs.
- Network Interface Cards and Uplinks.

GENERAL

- Provides a standard 5 signal IEEE 1149.1 JTAG test port for boundary scan board test purposes.
- Provides a generic 8-bit microprocessor bus interface for configuration, control and status monitoring.

BLOCK DIAGRAM

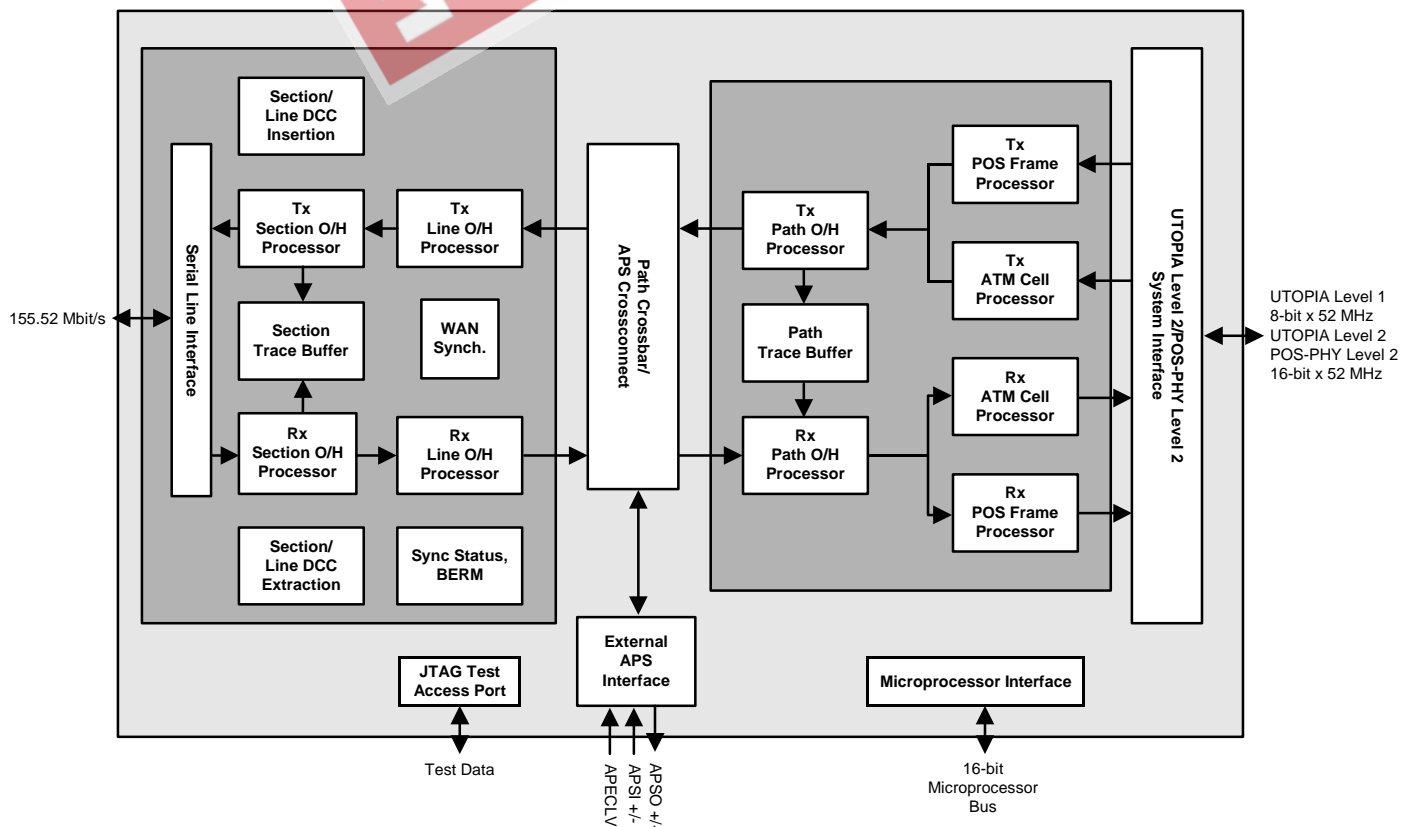

Single Channel OC-3c ATM and POS Physical Layer Device

TYPICAL APPLICATIONS

TYPICAL STS-3C/STM-1 ATM SWITCH PORT APPLICATION

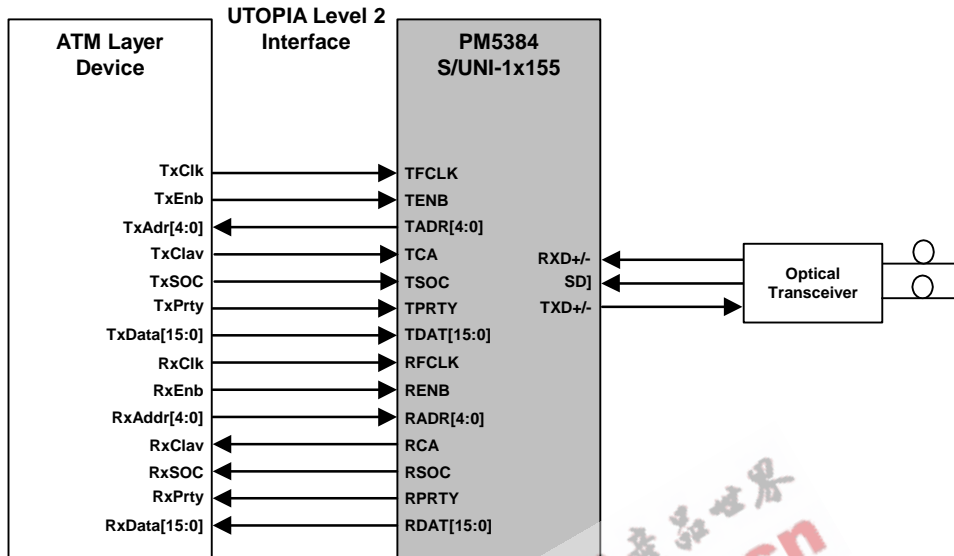

TYPICAL STS-3C/STM-1 PACKET-OVER-SONET/SDH APPLICATION

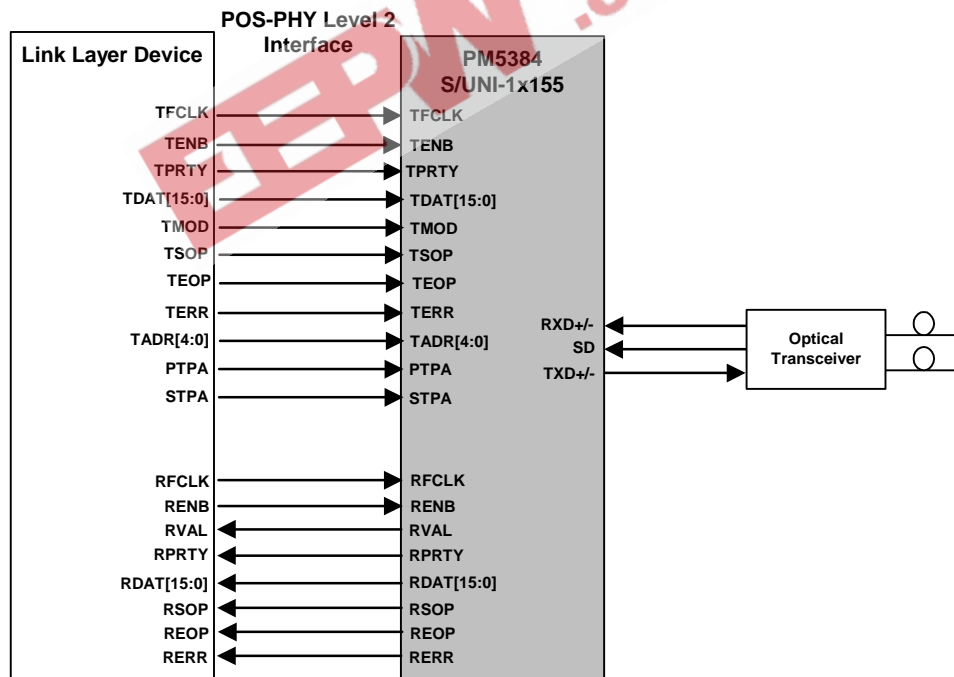

Head Office:
 PMC-Sierra, Inc.
 #105 - 8555 Baxter Place
 Burnaby, B.C. V5A 4V7
 Canada
 Tel: 604.415.6000
 Fax: 604.415.6200

To order documentation,
 send email to:
 document@pmc-sierra.com
 or contact the head office,
 Attn: Document Coordinator

All product documentation is available
 on our web site at:
<http://www.pmc-sierra.com>
 For corporate information,
 send email to:
 info@pmc-sierra.com

PMC-2011690 (A1)
 © Copyright PMC-Sierra,
 Inc. 2001. All rights reserved.
 SATURN and S/UNI are
 registered trademarks of
 PMC-Sierra, Inc.