

16-Channel OC-3c ATM and POS Physical Layer Device

FEATURES

- Single chip 16-channel ATM and POS User Network Interface operating at 155 Mbit/s.
- Implements the ATM Forum User Network Interface Specification and the ATM physical layer for Broadband ISDN according to CCITT Recommendation I.432.
- Implements the Point-to-Point Protocol (PPP) over SONET/SDH specification according to RFC 2615(1619)/1662 of the PPP Working Group of the Internet Engineering Task Force (IETF).
- Processes sixteen bit-serial 155 Mbit/s STS-3c (STM-1) data streams with on-chip clock and data recovery and clock synthesis.
- Complies with Bellcore GR-253-CORE jitter tolerance, jitter transfer and intrinsic jitter criteria.
- Each channel provides termination for SONET Section, Line and Path overhead or SDH Regenerator Section, Multiplexer Section and High Order Path overhead.
- Provides UTOPIA Level 3 32-bit wide System Interface (clocked up to 104 MHz) with parity support for ATM applications.
- Provides SATURN® POS-PHY Level 3™ 32-bit System Interface (clocked up to 104 MHz) for Packet over SONET (POS), or ATM applications.
- Supports line loopback from the line side receive stream to the transmit stream and diagnostic loopback from the line side transmit stream to the line side receive stream interface.
- Provides support for automatic protection switching including a bi-directional 4-bit PECL 622 MHz port for external APS with mate device.
- Built-in APS cross-connect for internal and external 1+1 and 1:n protection switching.
- Provides a standard five signal IEEE 1149.1 JTAG test port for boundary scan board test purposes.
- Provides a generic 16-bit microprocessor bus interface for configuration, control, and status monitoring.
- Low power 2.5 V CMOS core logic with 3.3 V CMOS/TTL compatible digital inputs and digital outputs. PECL inputs and outputs are 3.3 V compatible.
- Industrial temperature range (-40 °C to +85 °C).
- 520 pin SBGA package.
- Pin and software compatible with the PM5358 S/UNI-4x622.

APPLICATIONS

- ATM and Multiservice Switches, Routers, and Switch/Routers.
- SONET/SDH Add/Drop Multiplexers with data processing capabilities
- Uplink Cards.
- SONET/SDH ATM/POS Test Equipment.
- SONET/SDH Transport Equipment.

BLOCK DIAGRAM

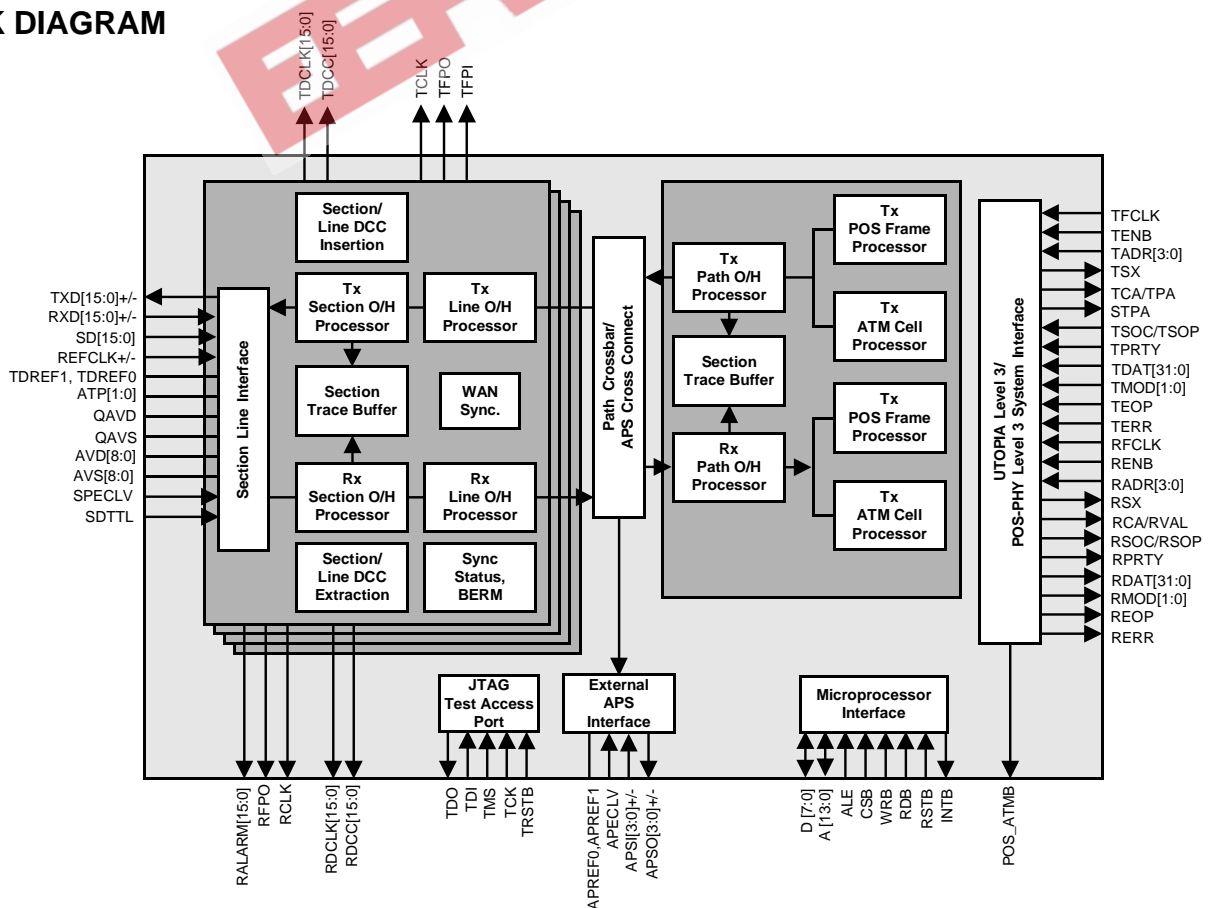

16-Channel OC-3c ATM and POS Physical Layer Device

TYPICAL APPLICATIONS

TYPICAL STS-3C/STM-1 ATM SWITCH PORT APPLICATION

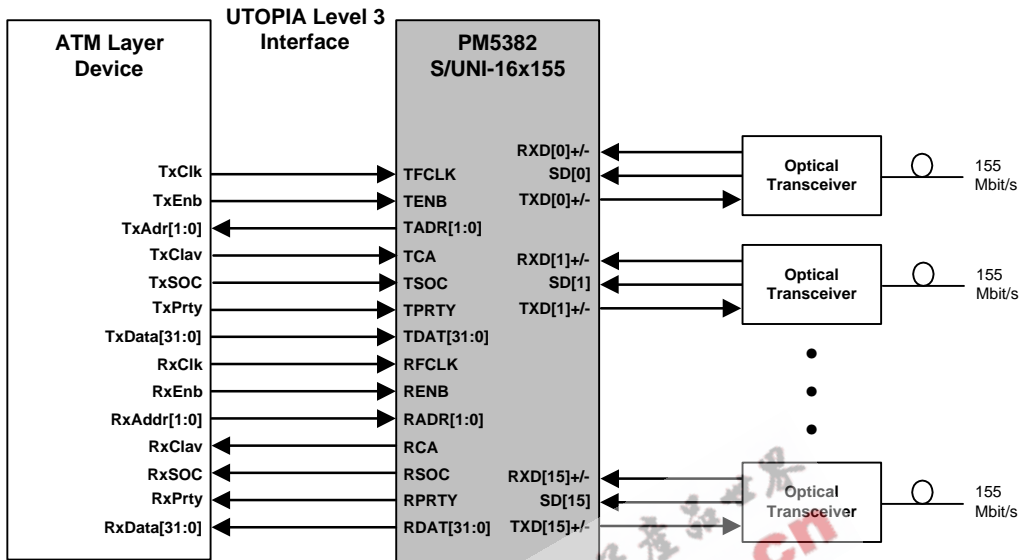

TYPICAL STS-3C/STM-1 PACKET-OVER-SONET/SDH APPLICATION

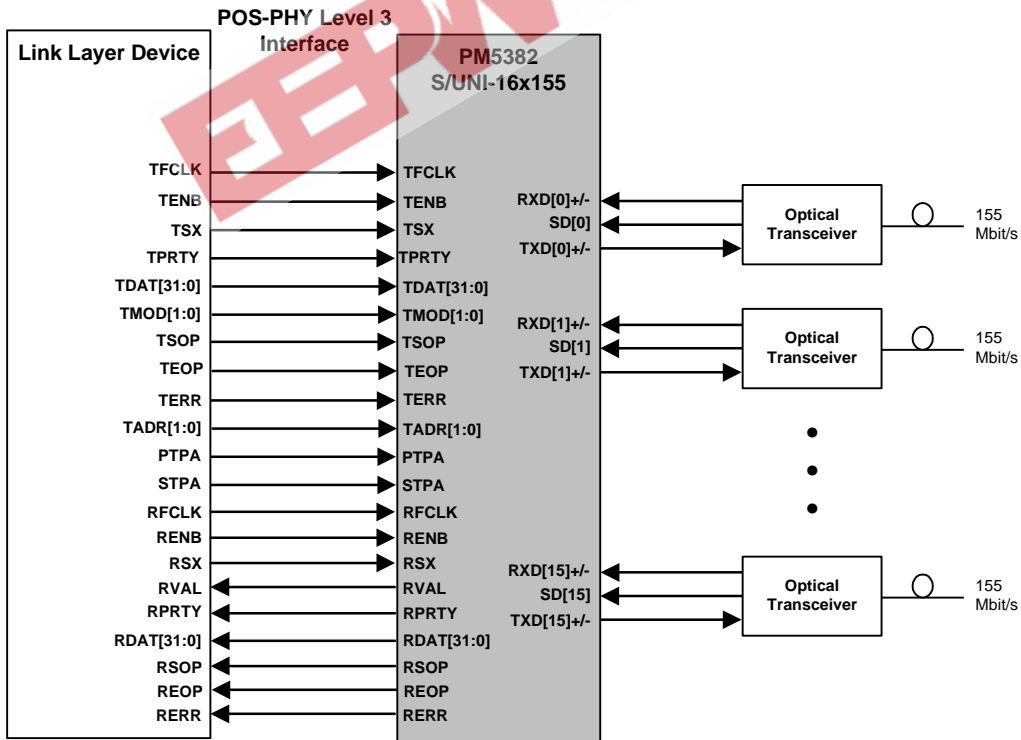

Head Office:
 PMC-Sierra, Inc.
 #105 - 8555 Baxter Place
 Burnaby, B.C. V5A 4V7
 Canada
 Tel: 604.415.6000
 Fax: 604.415.6200

To order documentation,
 send email to:
 document@pmc-sierra.com
 or contact the head office,
 Attn: Document Coordinator

All product documentation is available
 on our web site at:
<http://www.pmc-sierra.com>
 For corporate information,
 send email to:
 info@pmc-sierra.com

PMC-2001825 (A1)
 © Copyright PMC-Sierra,
 Inc. 2000. All rights reserved.
 SATURN and S/UNI are
 registered trademarks of
 PMC-Sierra, Inc. POS-PHY
 Level 3 is a trademark of
 PMC-Sierra, Inc.