

PNP Silicon High-Voltage Transistors

PZTA 92
PZTA 93

- High breakdown voltage
- Low collector-emitter saturation voltage
- Complementary types: PZTA 42, PZTA 43 (NPN)

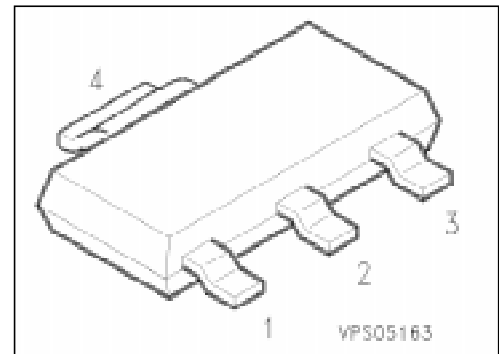

Type	Marking	Ordering Code (tape and reel)	Pin Configuration				Package ¹⁾
			1	2	3	4	
PZTA 92	PZTA 92	Q62702-Z2037	B	C	E	C	SOT-223
PZTA 93	PZTA 93	Q62702-Z2038					

Maximum Ratings

Parameter	Symbol	Values		Unit
		PZTA 92	PZTA 93	
Collector-emitter voltage	V_{CE0}	300	200	V
Collector-base voltage	V_{CB0}	300	200	
Emitter-base voltage	V_{EB0}	5		
Collector current	I_C	500		mA
Base current	I_B	100		
Total power dissipation, $T_s = 124\text{ °C}$	P_{tot}	1.5		W
Junction temperature	T_j	150		°C
Storage temperature range	T_{stg}	- 65 ... + 150		

Thermal Resistance

Junction - ambient ²⁾	$R_{th\ JA}$	≤ 72	K/W
Junction - soldering point	$R_{th\ JS}$	≤ 17	

¹⁾ For detailed information see chapter Package Outlines.

²⁾ Package mounted on epoxy pcb 40 mm × 40 mm × 1.5 mm/6 cm² Cu.

Electrical Characteristics

at $T_A = 25\text{ °C}$, unless otherwise specified.

Parameter	Symbol	Values			Unit
		min.	typ.	max.	

DC characteristics

Collector-emitter breakdown voltage $I_C = 1\text{ mA}$, $I_B = 0$	$V_{(BR)CE0}$				V
PZTA 92		300	–	–	
PZTA 93		200	–	–	
Collector-base breakdown voltage $I_C = 100\text{ }\mu\text{A}$, $I_B = 0$	$V_{(BR)CB0}$				
PZTA 92		300	–	–	
PZTA 93		200	–	–	
Emitter-base breakdown voltage $I_E = 100\text{ }\mu\text{A}$, $I_C = 0$	$V_{(BR)EB0}$	5	–	–	
Collector-base cutoff current $V_{CB} = 200\text{ V}$	I_{CB0}				nA
PZTA 92		–	–	250	
$V_{CB} = 160\text{ V}$				250	nA
PZTA 93		–	–	20	μA
$V_{CB} = 200\text{ V}$, $T_A = 150\text{ °C}$				20	μA
PZTA 92		–	–	20	
$V_{CB} = 160\text{ V}$, $T_A = 150\text{ °C}$				20	μA
PZTA 93		–	–	20	
Emitter-base cutoff current $V_{EB} = 3\text{ V}$, $I_C = 0$	I_{EB0}	–	–	100	nA
DC current gain ¹⁾ $I_C = 1\text{ mA}$, $V_{CE} = 10\text{ V}$	h_{FE}	25	–	–	–
$I_C = 10\text{ mA}$, $V_{CE} = 10\text{ V}$		40	–	–	
$I_C = 30\text{ mA}$, $V_{CE} = 10\text{ V}$		25	–	–	
Collector-emitter saturation voltage ¹⁾ $I_C = 20\text{ mA}$, $I_B = 2\text{ mA}$	V_{CEsat}				V
PZTA 92		–	–	0.5	
PZTA 93		–	–	0.4	
Base-emitter saturation voltage ¹⁾ $I_C = 20\text{ mA}$, $I_B = 2\text{ mA}$	V_{BEsat}	–	–	0.9	

AC characteristics

Transition frequency $I_C = 20\text{ mA}$, $V_{CE} = 10\text{ V}$, $f = 100\text{ MHz}$	f_t	–	100	–	MHz
Collector-base capacitance $V_{CB} = 20\text{ V}$, $f = 1\text{ MHz}$	C_{obo}				pF
PZTA 92		–	–	6	
PZTA 93		–	–	8	

¹⁾ Pulse test conditions: $t \leq 300\text{ }\mu\text{s}$, $D = 2\%$.

Total power dissipation $P_{tot} = f(T_A^*; T_S)$

* Package mounted on epoxy

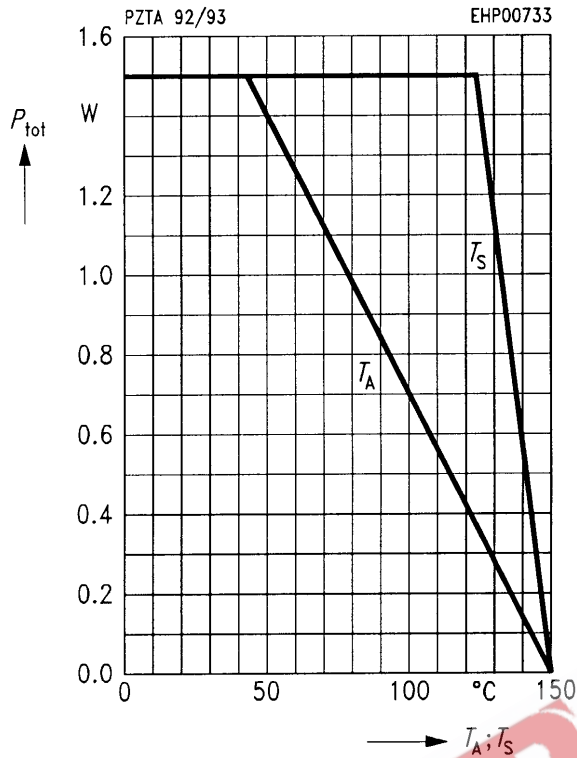

Transition frequency $f_T = f(I_C)$

$V_{CE} = 10\text{ V}, f = 100\text{ MHz}$

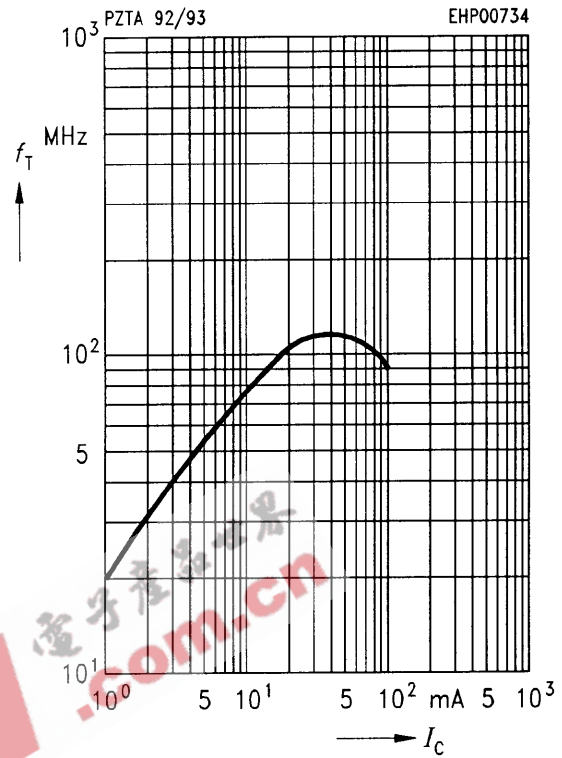

Permissible pulse load $P_{tot\ max} / P_{tot\ DC} = f(t_p)$

DC current gain $h_{FE} = f(I_C)$

$V_{CE} = 10\text{ V}$

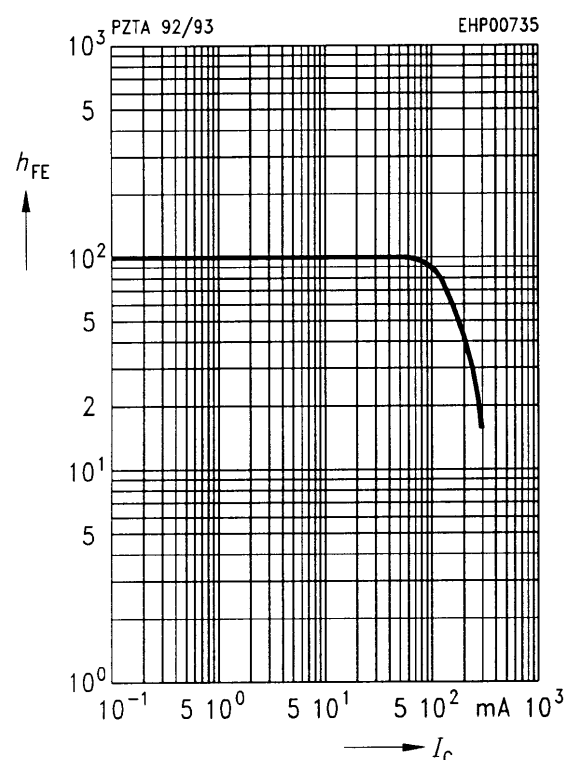
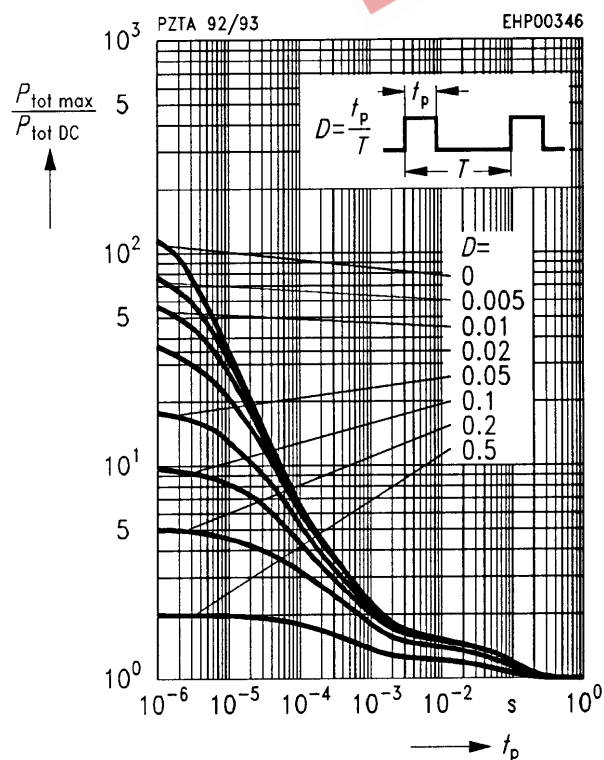

Collector cutoff current $I_{CB0} = f(T_A)$
 $V_{CB} = 160 \text{ V}$

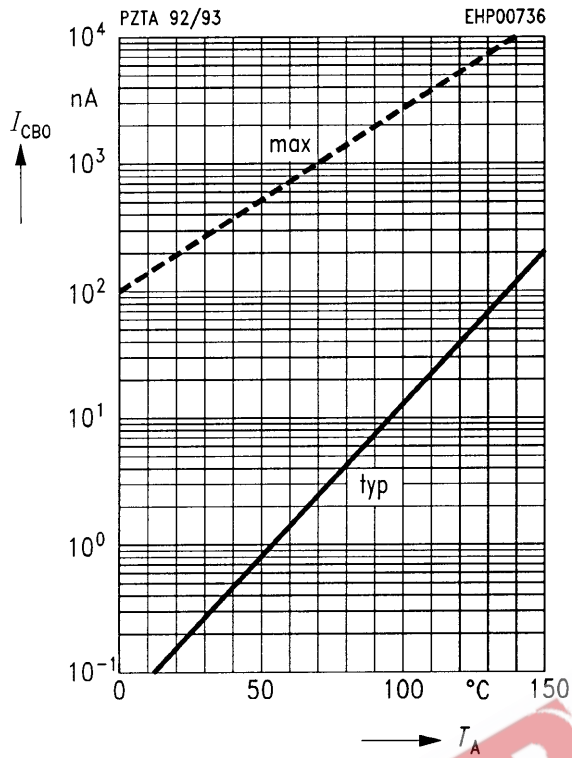

Collector current $I_C = f(V_{BE})$
 $V_{CE} = 10 \text{ V}$

