

P-Channel JFET Switch



2N5114 – 2N5116

GENERAL DESCRIPTION

Ideal for inverting switching or "Virtual Gnd" switching into inverting input of Op. Amp. No driver is required and $\pm 10\text{VAC}$ signals can be handled using only +5V logic (TTL or CMOS).

FEATURES

- Low ON Resistance
- $I_{D(\text{off})} < 500\text{pA}$
- Switches directly from TTL Logic

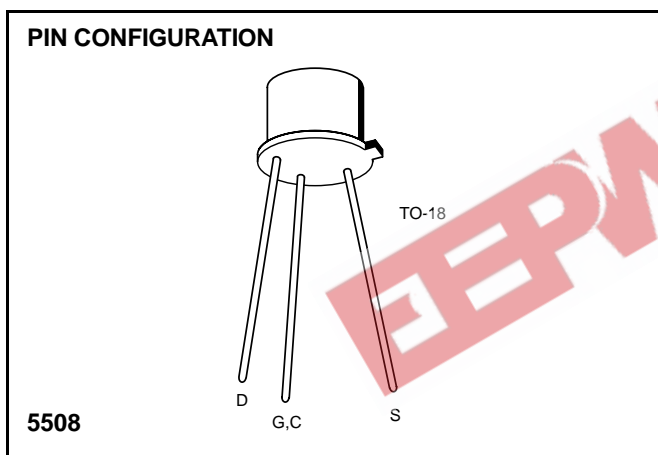

ABSOLUTE MAXIMUM RATINGS

($T_A = 25^\circ\text{C}$ unless otherwise noted)

Gate-Drain or Gate-Source Voltage	30V
Gate Current	50mA
Storage Temperature Range	-65°C to $+200^\circ\text{C}$
Operating Temperature Range	-55°C to $+200^\circ\text{C}$
Lead Temperature (Soldering, 10sec)	$+300^\circ\text{C}$
Power Dissipation	500mW
Derate above 25°C	$3\text{mW}/^\circ\text{C}$

NOTE: Stresses above those listed under "Absolute Maximum Ratings" may cause permanent damage to the device. These are stress ratings only and functional operation of the device at these or any other conditions above those indicated in the operational sections of the specifications is not implied. Exposure to absolute maximum rating conditions for extended periods may affect device reliability.

ORDERING INFORMATION

Part	Package	Temperature Range
2N5114-16	Hermetic TO-18	-55°C to $+200^\circ\text{C}$
X2N5114-16	Sorted Chips in Carriers	-55°C to $+200^\circ\text{C}$

SWITCHING CHARACTERISTICS ($T_A = 25^\circ\text{C}$ unless otherwise specified)

SYMBOL	PARAMETER	2N5114	2N5115	2N5116	UNITS
		MAX	MAX	MAX	
t_d	Turn-ON Delay Time	6	10	12	ns
t_r	Rise Time (Note 2)	10	20	30	
t_{off}	Turn-OFF Delay Time (Note 2)	6	8	10	
t_f	Fall Time (Note 2)	15	30	50	

ELECTRICAL CHARACTERISTICS ($T_A = 25^\circ\text{C}$ unless otherwise specified)

SYMBOL	PARAMETER	2N5114		2N5115		2N5116		UNITS	TEST CONDITIONS
		MIN	MAX	MIN	MAX	MIN	MAX		
BV_{GSS}	Gate-Source Breakdown Voltage	30		30		30		V	$I_G = 1\mu\text{A}, V_{DS} = 0$
I_{GSS}	Gate Reverse Current		500		500		500	pA	$V_{GS} = 20\text{V}, V_{DS} = 0$
			1.0		1.0		1.0	μA	$T_A 150^\circ\text{C}$
$I_{D(\text{off})}$	Drain Cutoff Current		-500		-500		-500	pA	$V_{DS} = -15\text{V}$ $V_{GS} = 12\text{V}$ (2N5114)
			-1.0		-1.0		-1.0	μA	$V_{GS} = 7\text{V}$ (2N5115) $V_{GS} = 5\text{V}$ (2N5116)
V_P	Gate-Source Pinch-Off Voltage	5	10	3	6	1	4	V	$V_{DS} = -15\text{V}, I_D = -1\text{nA}$

ELECTRICAL CHARACTERISTICS ($T_A = 25^\circ\text{C}$ unless otherwise specified) (Continued)

SYMBOL	PARAMETER	2N5114		2N5115		2N5116		UNITS	TEST CONDITIONS
		MIN	MAX	MIN	MAX	MIN	MAX		
I_{DSS}	Drain Current at Zero Gate Voltage (Note 1)	-30	-90	-15	-60	-5	-25	mA	$V_{GS} = 0$ $V_{DS} = -18\text{V}$ (2N5114) $V_{DS} = -15\text{V}$ (2N5115) $V_{DS} = -15\text{V}$ (2N5116)
$V_{GS(f)}$	Forward Gate-Source Voltage		-1		-1		-1	V	$I_G = -1\text{mA}$, $V_{DS} = 0$
$V_{DS(on)}$	Drain-Source ON Voltage		-1.3		-0.8		-0.6		$V_{GS} = 0$ $I_D = -15\text{mA}$ (2N5114) $I_D = -7\text{mA}$ (2N5115) $I_D = -3\text{mA}$ (2N5116)
$r_{DS(on)}$	Static Drain-Source ON Resistance		75		100		150	Ω	$V_{GS} = 0$, $I_D = -1\text{mA}$
$r_{ds(on)}$	Small-Signal Drain-Source ON Resistance		75		100		150		$V_{GS} = 0$, $I_D = 0$, $f = 1\text{kHz}$
C_{iss}	Common-Source Input Capacitance (Note 2)		25		25		25	pF	$V_{DS} = -15\text{V}$, $V_{GS} = 0$, $f = 1\text{MHz}$
C_{rss}	Common-Source Reverse Transfer Capacitance (Note 2)		7		7		7		$V_{DS} = 0$ $V_{GS} = 12\text{V}$ (2N5114) $V_{GS} = 7\text{V}$ (2N5115) $V_{GS} = 5\text{V}$ (2N5116) $f = 1\text{MHz}$

- NOTES**
1. Pulse test; duration = 2ms.
 2. For design reference only, not 100% tested.

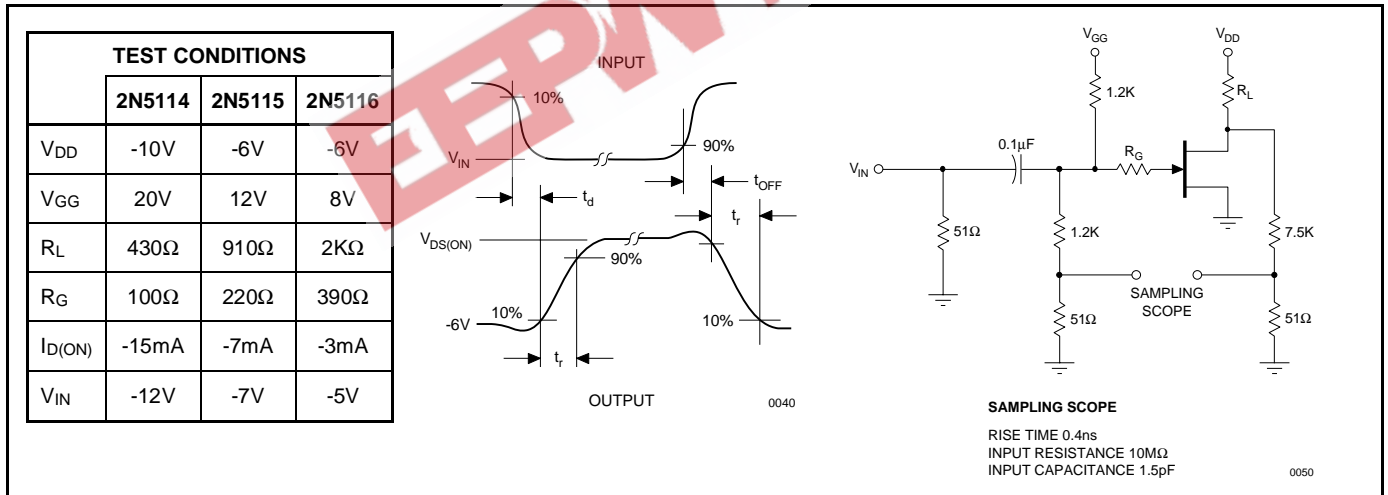

TYPICAL PERFORMANCE CHARACTERISTICS

