

HiMARK Technology, Inc. reserves the right to change the product described in this datasheet. All information contained in this datasheet is subject to change without prior notice. HiMARK Technology, Inc. assumes no responsibility for the use of any circuits shown in this datasheet.

Description

The RX3140 is a low power IF receiver IC which is fully compatible with the Toshiba TA31142 IC and is suitable for use as the second IF downconverter in double-conversion paging systems. The RX3140 is well-suited for POCSAG paging applications and incorporates a 2-level FSK demodulator consisting of a quadrature FM demodulator, on-chip bit-rate filter, and 1-bit comparator. An on-chip 1 V regulator is provided for convenient biasing of off-chip circuitry.

Features

- ◆ Extremely low power operation with power-down feature
- ◆ Built-in crystal oscillator for mixer local oscillator
- ◆ Mixer input frequency: 10 — 50 MHz
- ◆ Quadrature detector
- ◆ On-chip bit-rate filter
- ◆ Audio output
- ◆ 1-bit comparator with open collector output
- ◆ 1 V regulator
- ◆ 1.1 V low battery alarm
- ◆ SSOP-20 package (0.65 mm pitch)

Block Diagram

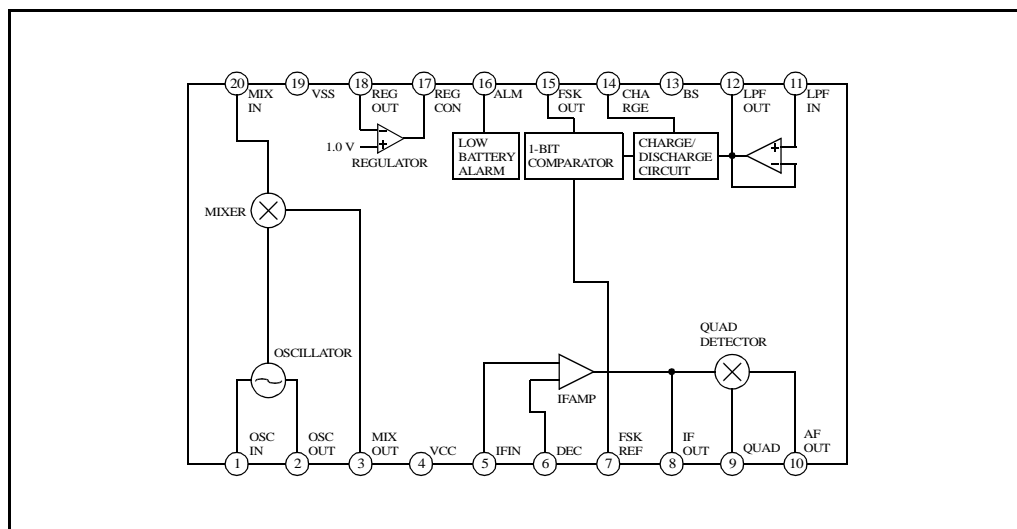

Pin Descriptions

Number	Name	Description
1	OSCIN	Oscillator input (base)
2	OSCOUT	Oscillator output (emitter)
3	MIXOUT	Mixer output (2 K Ω output impedance)
4	VCC	Nominal 1.4 V supply
5	IFIN	IF amplifier input (2 K Ω input impedance)
6	DEC	IF amplifier de-coupling capacitor connection
7	FSKREF	1-bit comparator reference input (requires external capacitor)
8	IFOUT	IF amplifier output
9	QUAD	Quadrature FM demodulator input
10	AFOUT	Quadrature FM demodulator output
11	LPFIN	LPF operational amplifier input
12	LPFOUT	LPF operational amplifier output
13	BS	Two-state logic input to control receiver power up/down. (BS = high = normal operation; BS = low = stand-by mode)

Number	Name	Description
14	CHARGE	Two-state logic input to control charge-discharge circuit. (CHARGE = high = fast charge; CHARGE = low = slow charge)
15	FSKOUT	Open collector NRZ comparator output (requires pull-up resistor)
16	ALM	Open collector low battery alarm output (requires pull-up resistor)
17	REGCON	1.0 V regulator control output for connection to external PNP base
18	REGOUT	1.0 V regulator input for connection to external PNP collector
19	VSS	Ground
20	MIXIN	Mixer input (5 K Ω input impedance)

Absolute Maximum Ratings

$$V_{SS} = 0 \text{ V}$$

Parameter	Symbol	Rating	Unit
Supply voltage	V_{CC}	$V_{SS} - 0.3$ to $V_{SS} + 3.5$	V
Operating temperature range	T_{OPR}	-30 to 85	°C
Storage temperature range	T_{STG}	-55 to 150	°C
Soldering temperature range	T_{SLD}	255	°C
Soldering time range	t_{SLD}	10	s

Recommended Operating Conditions

$$V_{SS} = 0 \text{ V}$$

Parameter	Symbol	Value			Unit
		min.	typ.	max.	
Supply voltage range	V_{CC}	1.1	1.35	1.6	V
MIXIN input frequency	f_{MIXIN}			50	MHz
Operating temperature	T_A	-10	25	60	°C

Electrical Characteristics

($V_{CC} = 1.4\text{ V}$, $V_{SS} = 0\text{ V}$, $T_A = 25\text{ }^\circ\text{C}$, BS = high unless otherwise noted)

Parameter	Symbol	Condition	Value			Unit
			min.	typ.	max.	
Quiescent current consumption	$I_{CC,total}$			1.1	1.6	mA
Standby current consumption	$I_{CC,standby}$	$V_{BS} = 0\text{ V}$			5	μA
Mixer conversion gain	G_C	measured after 455 KHz ceramic filter	9	12.5	16	dB
Mixer output intermodulation intercept point	OIP3			-10		dBm
Mixer input resistance	$R_{in,MIX}$			5		$\text{K}\Omega$
Mixer output resistance	$R_{out,MIX}$			2		$\text{K}\Omega$
IF amplifier input resistance	$R_{in,IF}$			2		$\text{K}\Omega$
S/N ratio 1	SN1	-53 dBm at MIXIN		63		dB
S/N ratio 2	SN2	-53 dBm at IFIN		63		dB
S/N ratio 3	SN3	-91 dBm at IFIN		25		dB
Demodulation output level	VOD	-53 dBm at IFIN		45		mVrms
AM rejection ratio	AMR	-53 dBm at IFIN, AM=30 %		50		dB
FSK output duty ratio	DR		40	50	60	%
Low battery alarm threshold voltage	V_{ALM}		1.05	1.1	1.15	V
Regulator output voltage	V_{REGOUT}	430 Ω load resistor	0.95	1.0	1.05	V
Charging/discharging current	I_{CH}	$V_{FSKREF} = 0\text{ V}$, $V_{LPFOUT} = 0.18\text{ V}$	35	70	110	μA
ALM logic HIGH output current	$I_{OH,ALM}$				2	μA
ALM logic LOW output voltage	$V_{OL,ALM}$				0.4	V
FSKOUT logic HIGH output current	$I_{OH,FSK-OUT}$				2	μA
FSKOUT logic LOW output voltage	$V_{OL,FSK-OUT}$				0.4	V

Functional Description

The RX3140 IF receiver IC incorporates a mixer, crystal-based local oscillator, IF amplifier, quadrature FM demodulator, bit-rate filter, and 1-bit comparator and is capable of demodulating 2-level FSK input signals. In addition, 1.0 V regulator and 1.1 V low battery alarm functions are provided.

Power-down Function

The entire receiver IC may be powered up and down through the control of the BS input (pin 13). During power down operation, the quiescent current consumption of the IC drops to approximately 0 μ A. The high input impedance of the BS pin allows for direct interfacing with the CMOS output of an off-chip microcontroller.

Charge/Discharge Circuitry

The function of the charge/discharge circuitry is for both fast and slow charging/discharging of the capacitor used for storing the voltage reference level of the FSKREF pin. The CHARGE input (pin 14) should be enabled (CHARGE = high = fast charge) immediately after transition of the receiver IC from power-down to normal operation in order to reduce the charging/discharging time for coarse adjustment of the FSKREF voltage to the appropriate dc level (*i.e.* dc level of the LPFOUT pin) and consequently to minimize the erroneous output of the 1-bit comparator. During actual data reception, the CHARGE pin should be set to low (CHARGE = low = slow charge) for fine adjustment of the FSKREF voltage.

1-bit Comparator

The integrated 1-bit comparator operates as a data slicer and “squares up” the bit-rate filtered output from the quadrature demodulator. The decision threshold voltage level for the 1-bit comparator is stored on an external capacitor connected to the FSKREF pin.

Regulator

The on-chip 1.0 V regulator requires a suitable off-chip PNP transistor to achieve regulation. The external PNP transistor should have an $h_{FE} > 200$ for $V_{CE} \geq 0.1$ V.

Low Battery Alarm

The low battery alarm output, ALM, is normally low, but rises to 1.1 V (\approx VCC) when the VCC voltage falls below approximately 1.1 V.

Typical Performance Characteristics

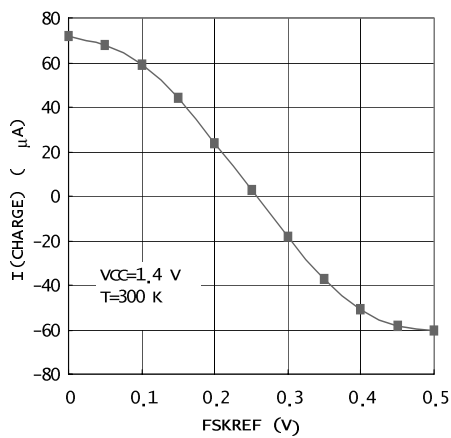
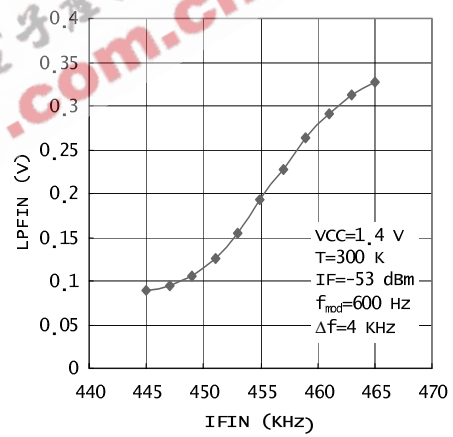
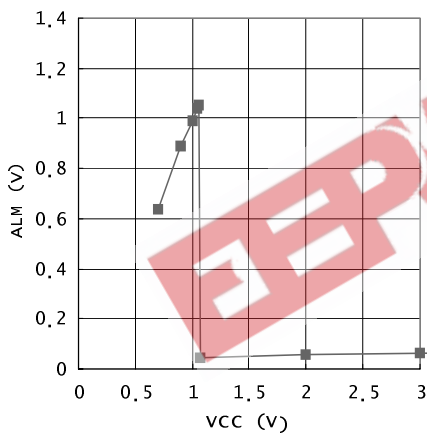
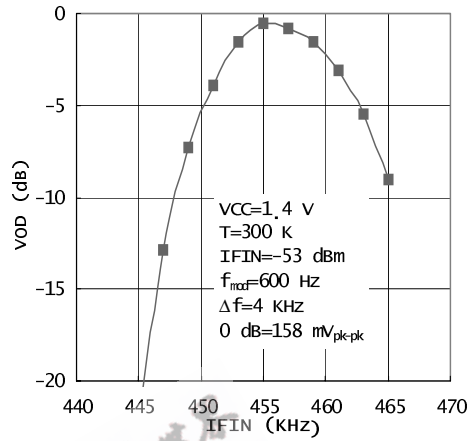
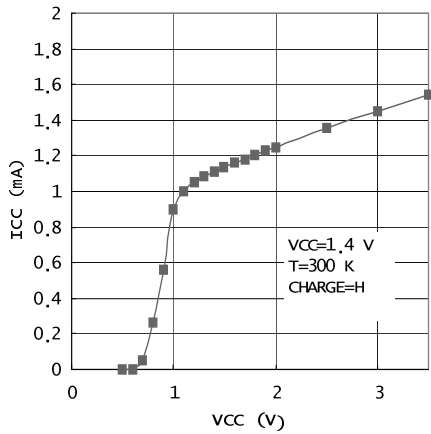

Test Circuit

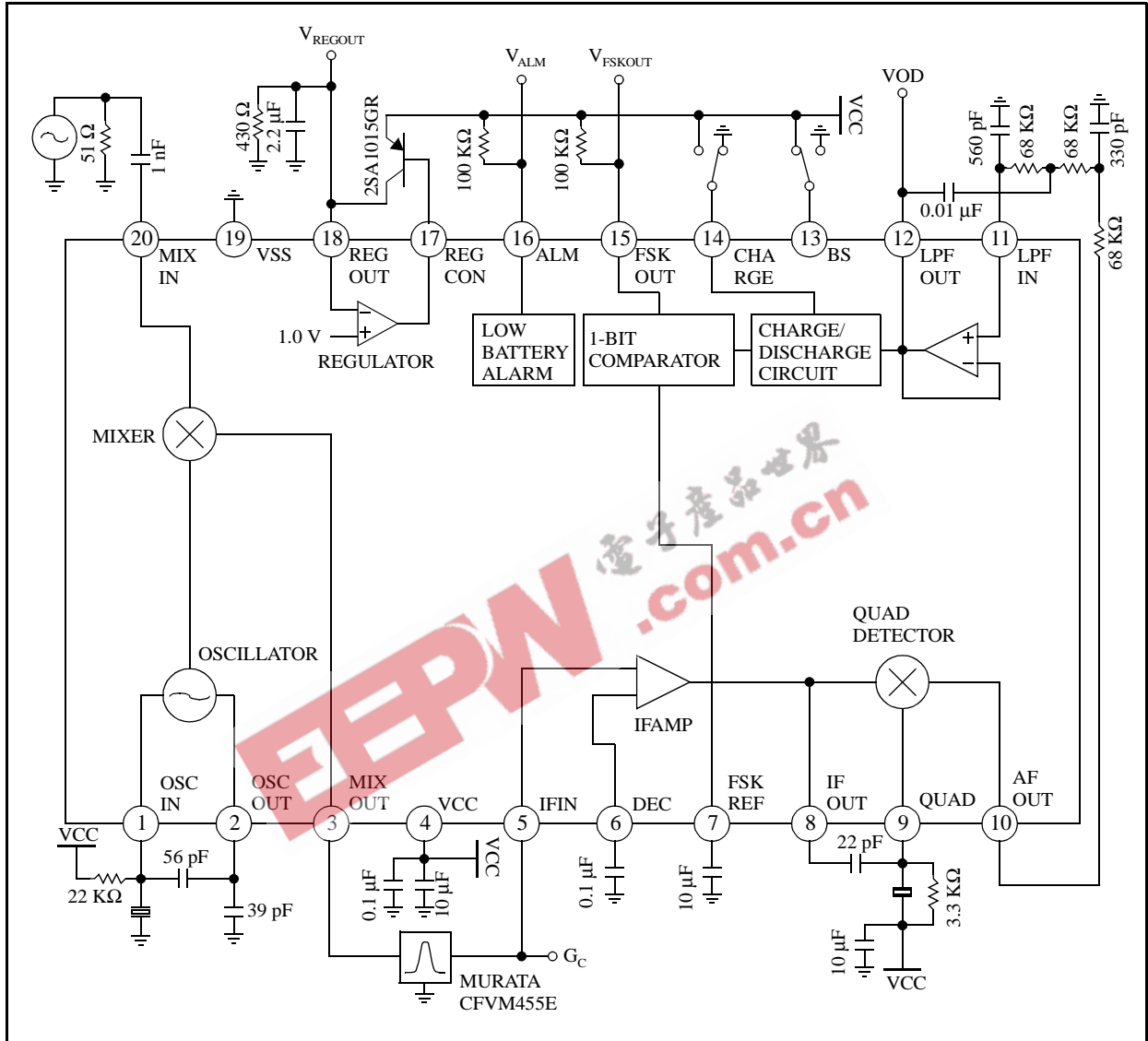

Application Circuit

