

April 1995

4A, 100V - 200V Ultrafast Diodes

### Features

- Ultrafast with Soft Recovery ..... <30ns
- Operating Temperature ..... +175°C
- Reverse Voltage Up to ..... 200V
- Avalanche Energy Rated
- Planar Construction

### Applications

- Switching Power Supplies
- Power Switching Circuits
- General Purpose

### Description

RURD410, RURD415, RURD420, RURD410S, RURD415S, and RURD420S (TA49034) are ultrafast diodes with soft recovery characteristics ( $t_{RR} < 30ns$ ). They have low forward voltage drop and are ion-implanted epitaxial planar construction.

These devices are intended for use as freewheeling/clamping diodes and rectifiers in a variety of switching power supplies and other power switching applications. Their low stored charge and ultrafast soft recovery minimize ringing and electrical noise in many power switching circuits, reducing power loss in the switching transistors.

### Package

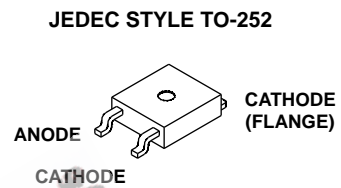
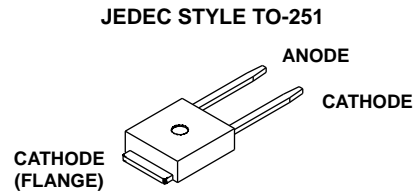

### Symbol



### PACKAGING AVAILABILITY

PART NUMBER	PACKAGE	BRAND
RURD410	TO-251	RUR410
RURD415	TO-251	RUR415
RURD420	TO-251	RUR420
RURD410S	TO-252	RUR410
RURD415S	TO-252	RUR415
RURD420S	TO-252	RUR420

NOTE: When ordering, use the entire part number.

### Absolute Maximum Ratings $T_C = +25^\circ C$ , Unless Otherwise Specified

	RURD410 RURD410S	RURD415 RURD415S	RURD420 RURD420S	UNITS
Peak Repetitive Reverse Voltage..... $V_{RRM}$	100	150	200	V
Working Peak Reverse Voltage..... $V_{RWM}$	100	150	200	V
DC Blocking Voltage..... $V_R$	100	150	200	V
Average Rectified Forward Current..... $I_{F(AV)}$ ( $T_C = +159^\circ C$ )	4	4	4	A
Repetitive Peak Surge Current..... $I_{FSM}$ (Square Wave, 20kHz)	8	8	8	A
Nonrepetitive Peak Surge Current..... $I_{FSM}$ (Halfwave, 1 Phase, 60Hz)	40	40	40	A
Maximum Power Dissipation..... $P_D$	30	30	30	W
Avalanche Energy (L = 40mH)..... $E_{AVL}$	10	10	10	mj
Operating and Storage Temperature..... $T_{STG}, T_J$	-65 to +175	-65 to +175	-65 to +175	°C

## Specifications RURD410, RURD415, RURD420, RURD410S, RURD415S, RURD420S

### Electrical Specifications $T_C = +25^\circ\text{C}$ , Unless Otherwise Specified

SYMBOL	TEST CONDITION	LIMITS									UNITS
		RURD410 RURD410S			RURD415 RURD415S			RURD420 RURD420S			
		MIN	TYP	MAX	MIN	TYP	MAX	MIN	TYP	MAX	
$V_F$	$I_F = 4\text{A}, T_C = +25^\circ\text{C}$	-	-	1.0	-	-	1.0	-	-	1.0	V
$V_F$	$I_F = 4\text{A}, T_C = +150^\circ\text{C}$	-	-	0.83	-	-	0.83	-	-	0.83	
$I_R$	$V_R = 100\text{V}, T_C = +25^\circ\text{C}$	-	-	100	-	-	-	-	-	-	$\mu\text{A}$
	$V_R = 150\text{V}, T_C = +25^\circ\text{C}$	-	-	-	-	-	100	-	-	-	
	$V_R = 200\text{V}, T_C = +25^\circ\text{C}$	-	-	-	-	-	-	-	-	100	
$I_R$	$V_R = 100\text{V}, T_C = +150^\circ\text{C}$	-	-	500	-	-	-	-	-	-	$\mu\text{A}$
	$V_R = 150\text{V}, T_C = +150^\circ\text{C}$	-	-	-	-	-	500	-	-	-	
	$V_R = 200\text{V}, T_C = +150^\circ\text{C}$	-	-	-	-	-	-	-	-	500	
$t_{RR}$	$I_F = 1\text{A}, dl_F/dt = 100\text{A}/\mu\text{s}$	-	-	30	-	-	30	-	-	30	ns
	$I_F = 4\text{A}, dl_F/dt = 100\text{A}/\mu\text{s}$	-	-	35	-	-	35	-	-	35	
$t_A$	$I_F = 4\text{A}, dl_F/dt = 100\text{A}/\mu\text{s}$	-	11	-	-	11	-	-	11	-	
$t_B$	$I_F = 4\text{A}, dl_F/dt = 100\text{A}/\mu\text{s}$	-	9	-	-	9	-	-	9	-	
$Q_{RR}$	$I_F = 4\text{A}, dl_F/dt = 100\text{A}/\mu\text{s}$	-	12	-	-	12	-	-	12	-	
$C_J$	$V_R = 10\text{V}, I_F = 0\text{A}$	-	15	-	-	15	-	-	15	-	
$R_{\theta JC}$		-	-	5	-	-	5	-	-	5	

#### DEFINITIONS

$V_F$  = Instantaneous forward voltage ( $p_w = 300\mu\text{s}$ ,  $D = 2\%$ ).

$I_R$  = Instantaneous reverse current.

$t_{RR}$  = Reverse recovery time (See Figure 2), summation of  $t_A + t_B$ .

$t_A$  = Time to reach peak reverse current (See Figure 2).

$t_B$  = Time from peak  $I_{RM}$  to projected zero crossing of  $I_{RM}$  based on a straight line from peak  $I_{RM}$  through 25% of  $I_{RM}$  (See Figure 2).

$R_{\theta JC}$  = Thermal resistance junction to case.

$E_{AVL}$  = Controlled avalanche energy (See Figures 9 and 10).

$p_w$  = pulse width.

$D$  = duty cycle.

$V_1$  AMPLITUDE CONTROLS  $I_F$   
 $V_2$  AMPLITUDE CONTROLS  $dl_F/dt$   
 $L_1$  = SELF INDUCTANCE OF  
 $R_4 + L_{LOOP}$

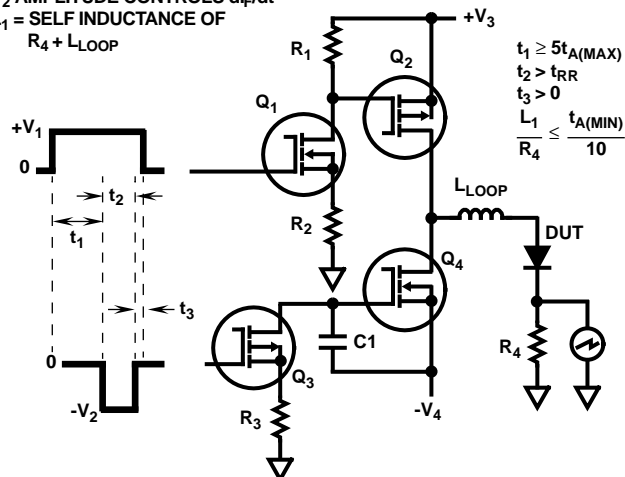

FIGURE 1.  $t_{RR}$  TEST CIRCUIT

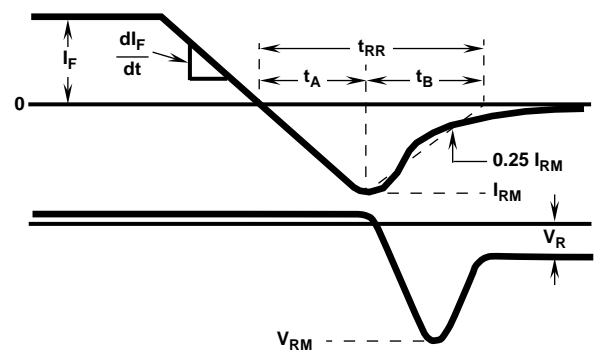

FIGURE 2.  $t_{RR}$  WAVEFORMS AND DEFINITIONS

RURD410, RURD415, RURD420, RURD410S, RURD415S, RURD420S

Typical Performance Curves

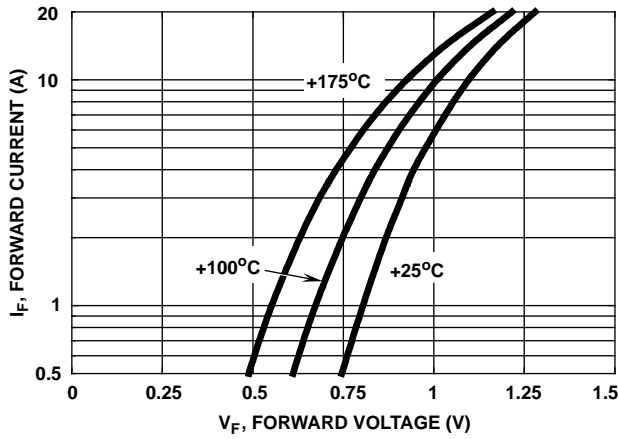

FIGURE 3. TYPICAL FORWARD CURRENT vs FORWARD VOLTAGE DROP

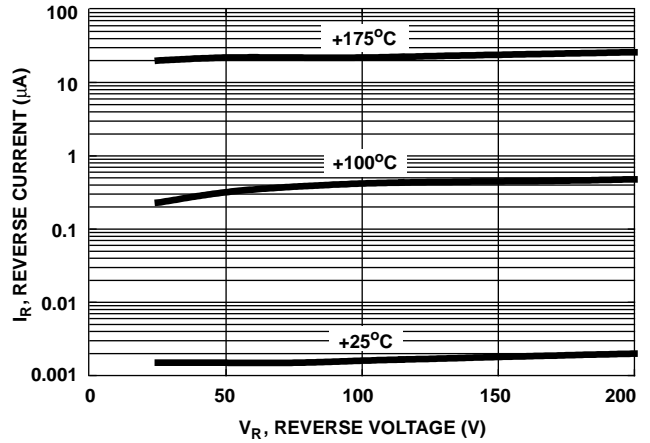

FIGURE 4. TYPICAL REVERSE CURRENT vs REVERSE VOLTAGE

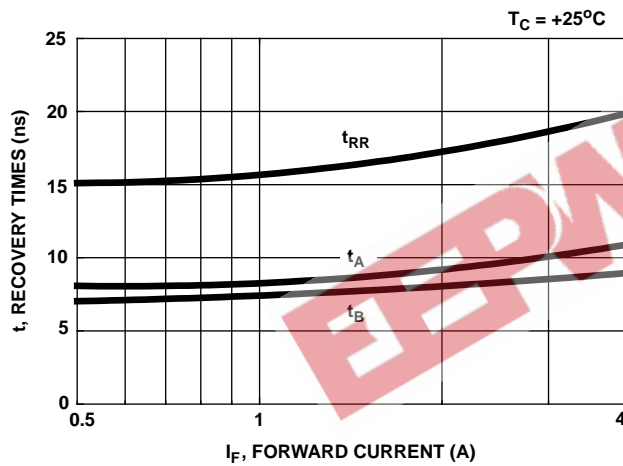

FIGURE 5. TYPICAL  $t_{RR}$ ,  $t_A$  AND  $t_B$  CURVES vs FORWARD CURRENT

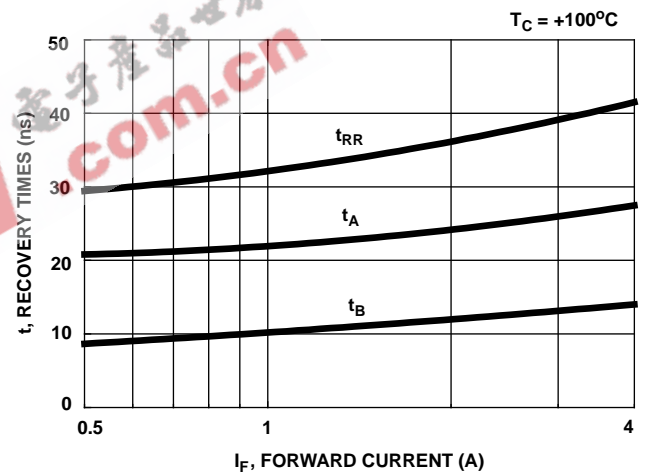

FIGURE 6. TYPICAL  $t_{RR}$ ,  $t_A$  AND  $t_B$  CURVES vs FORWARD CURRENT

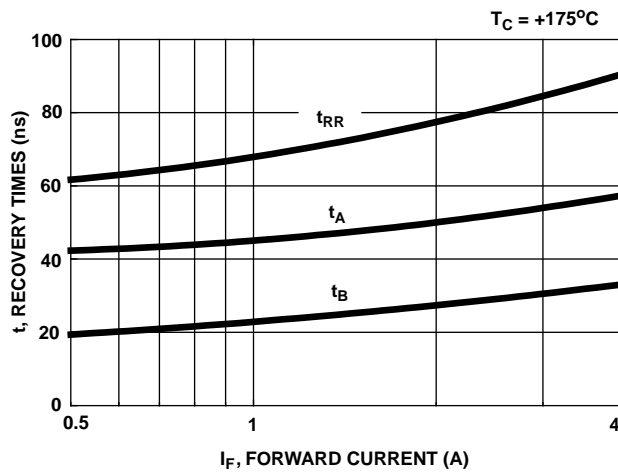

FIGURE 7. TYPICAL  $t_{RR}$ ,  $t_A$  AND  $t_B$  CURVES vs FORWARD CURRENT

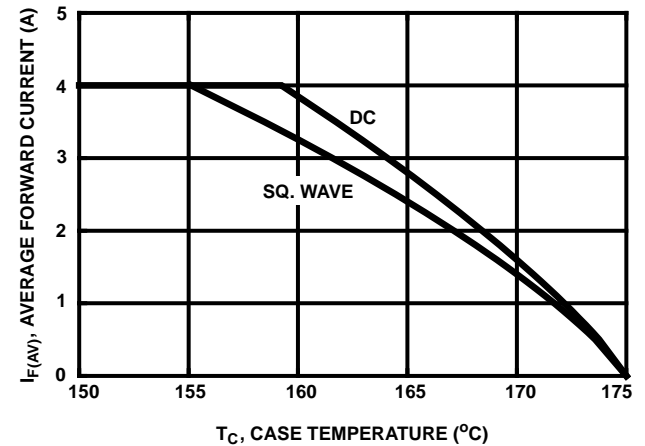

FIGURE 8. CURRENT DERATING CURVE FOR ALL TYPES

RURD410, RURD415, RURD420, RURD410S, RURD415S, RURD420S

$I_{MAX} = 1A$

$L = 40mH$

$R < 0.1\Omega$

$E_{AVL} = 1/2LI^2 [V_{AVL}/(V_{AVL} - V_{DD})]$

$Q_1$  AND  $Q_2$  ARE 1000V MOSFETS

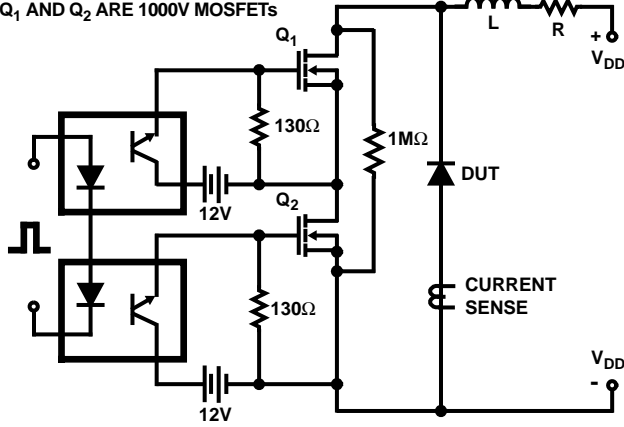

FIGURE 9. AVALANCHE ENERGY TEST CIRCUIT

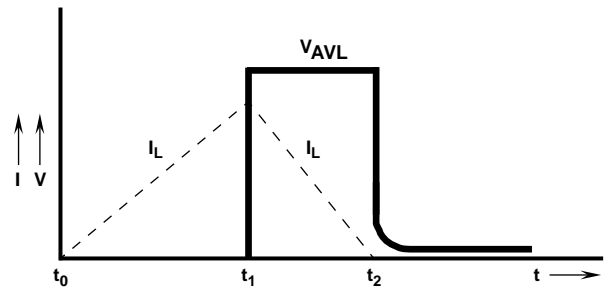

FIGURE 10. AVALANCHE CURRENT AND VOLTAGE WAVEFORMS

EEPW 电子产品世界 .com.cn