

HiMARK Technology, Inc. reserves the right to change the product described in this datasheet. All information contained in this datasheet is subject to change without prior notice. HiMARK Technology, Inc. assumes no responsibility for the use of any circuits shown in this datasheet.

## Description

The RX3400 is a low power ASK receiver IC which is fully compatible with the Mitel KESRX01 IC and is suitable for use in a variety of low power radio applications including remote keyless entry. The RX3400 is based on a single-conversion, super-heterodyne receiver architecture and incorporates an entire phase-locked loop (PLL) for precise local oscillator generation. In addition, the RX3400 provides an RSSI output.

## Features

- ◆ Extremely low power operation
- ◆ Low external part count
- ◆ Receiver input frequency: 290 – 460 MHz
- ◆ On-chip VCO with integrated PLL using crystal oscillator reference
- ◆ PLL power down feature
- ◆ Integrated IF and data filters
- ◆ RSSI output
- ◆ SSOP-24 package (0.64 mm pitch)

## Applications

- ◆ Wireless mouse
- ◆ Video sender remote controller
- ◆ Car alarm and home security systems

## Block Diagram

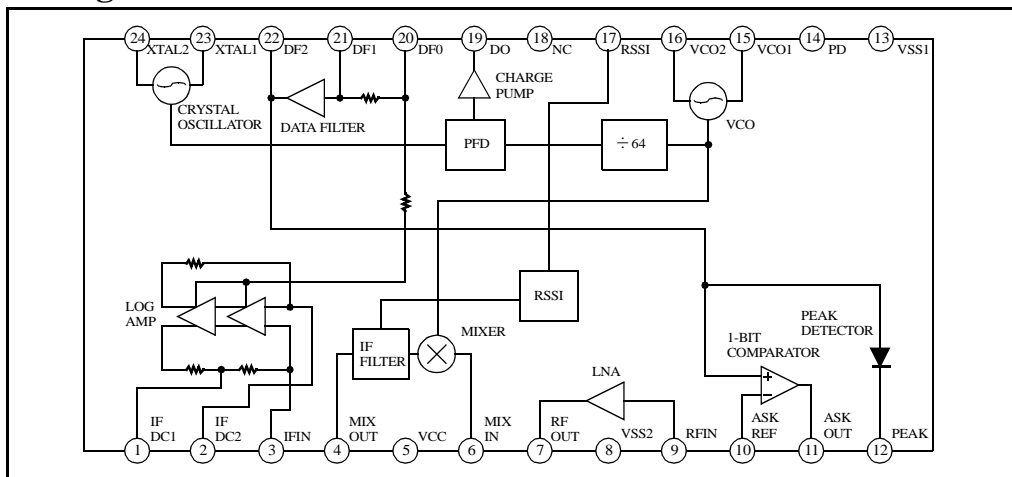

## Package and Pin Assignment

SSOP-24 (0.64 mm pitch)

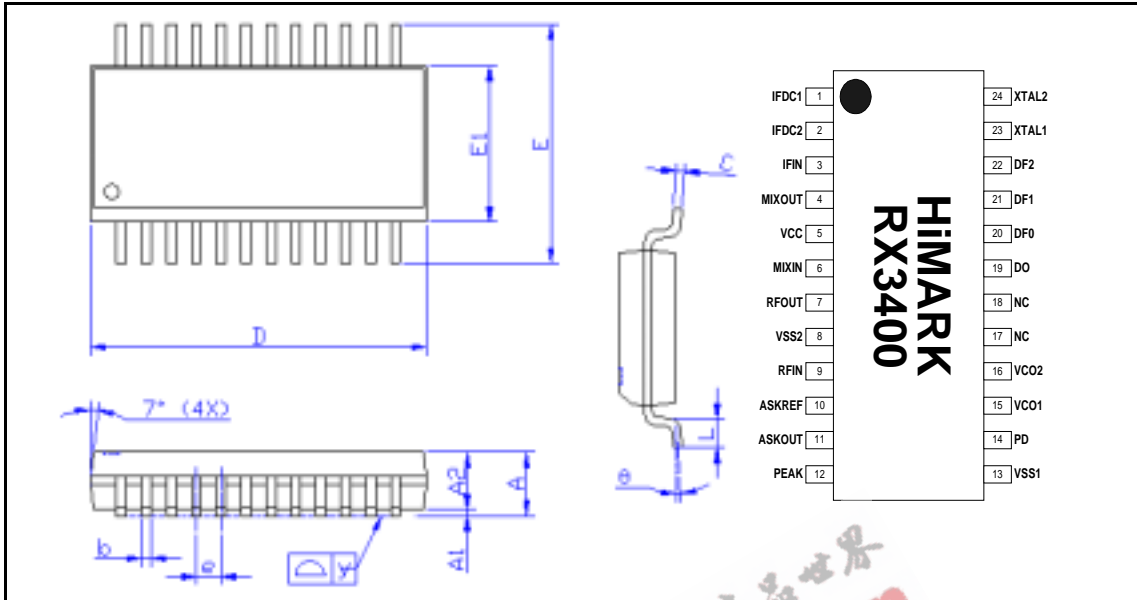

Symbols	Dimensions in mm			Dimensions in inch		
	min.	nom.	max.	min.	nom.	max.
A	1.35	1.60	1.75	0.053	0.064	0.069
A1	0.10	—	0.25	0.004	—	0.010
A2	—	1.45	—	—	0.057	—
b	0.20	0.25	0.30	0.008	0.010	0.012
C	0.19	—	0.25	0.007	—	0.010
D	8.55	—	8.75	0.337	—	0.344
E	5.80	—	6.20	0.228	—	0.244
E1	3.80	—	4.00	0.150	—	0.157
e	—	0.64	—	—	0.025	—
L	0.40	—	1.27	0.016	—	0.050
y	—	—	0.10	—	—	0.004
θ	0°	—	8°	0°	—	8°

## Pin Descriptions

Number	Name	Description
1	IFDC1	IF amplifier feedback decoupling connections
2	IFDC2	
3	IFIN	IF amplifier input
4	MIXOUT	Mixer output
5	VCC	Nominal 5 V supply
6	MIXIN	RF mixer input
7	RFOUT	Open collector LNA output
8	VSS2	LNA ground
9	RFIN	LNA input
10	ASKREF	Comparator reference level
11	ASKOUT	Comparator output
12	PEAK	Peak detector output

Number	Name	Description
13	VSS1	Ground
14	PD	PLL power down
15	VCO1	Open collector differential VCO outputs
16	VCO2	
17	RSSI	RSSI output
18	NC	No connection
19	DO	Loop filter output
20	DF0	Data filter external connections
21	DF1	
22	DF2	
23	XTAL1	Crystal oscillator external connections
24	XTAL2	

EEPW.com.cn

## Absolute Maximum Ratings

$$V_{SS} = V_{SS1} = V_{SS2} = 0 \text{ V}$$

Parameter	Symbol	Rating	Unit
Supply voltage	$V_{CC}$	$V_{SS} - 0.5$ to $V_{SS} + 8.0$	V
Operating temperature range	$T_{OPR}$	-40 to 85	°C
Storage temperature range	$T_{STG}$	-55 to 150	°C
Soldering temperature range	$T_{SLD}$	255	°C
Soldering time range	$t_{SLD}$	10	s

## Recommended Operating Conditions

$$V_{SS1} = V_{SS2} = 0 \text{ V}$$

Parameter	Symbol	Value			Unit
		min.	typ.	max.	
Supply voltage range	$V_{CC}$	4.75	5.0	7.0	V
RF input frequency	$f_{RFIN}$	290		460	MHz
Operating temperature	$T_A$	-10	25	60	°C

## Electrical Characteristics

( $V_{CC} = 4.75$  to  $7.0$  V,  $V_{SS1} = V_{SS2} = 0$  V,  $T_A = -40$  to  $85$  °C unless otherwise noted)

Parameter	Symbol	Condition	Value			Unit
			min.	typ.	max.	
Current consumption	$I_{CC, total}$	$V_{CC} = 5$ V		2.4	3.0	mA
Current consumption (PLL off)	$I_{CC, noPLL}$	$V_{CC} = 5$ V; $V_{PD} = 0$ V		1.8	2.4	mA
Sensitivity <sup>a</sup>	$\alpha_{SENS}$	$f_{RFIN} = 434$ MHz; 2 KB/s		-103	-100	dBm
Signal handling <sup>b</sup>	$\alpha_{SH}$	$f_{RFIN} = 434$ MHz; 2 KB/s	-30			dBm
Integrated IF filter -3-dB low pass cutoff frequency	$f_{IF, -3dB}$		450	550	750	KHz
Adjacent channel rejection <sup>c</sup>	$\alpha_{ACR}$			65		dB
Peak detector source current	$I_{peak}$			500		$\mu$ A
Peak detector leakage current	$I_{leak}$				250	nA
Charge pump source/sink current	$I_{CP}$			$\pm 30$		$\mu$ A
PD logic HIGH input voltage	$V_{IH, PD}$		$V_{CC} - 0.5$		$V_{CC} + 0.5$	V
PD logic LOW input voltage	$V_{IL, PD}$		$V_{SS2} - 0.5$		$V_{SS2} + 0.5$	V
ASKOUT logic HIGH output voltage	$V_{OH, ASKOUT}$	$I_{load} = 10$ $\mu$ A	$0.7 \times V_{CC}$			V
ASKOUT logic LOW output voltage	$V_{OL, ASKOUT}$	$I_{load} = 10$ $\mu$ A			$0.3 \times V_{CC}$	V

- Sensitivity is defined as the minimum average signal level measured at the input which is necessary to achieve a bit error rate of 0.01 when the input signal is a return-to-zero (RZ) pulse with an average duty cycle of 50%. The RF input is assumed to be matched to 50 ohms.
- Signal handling is defined as the maximum input signal capable of being successfully demodulated. It is assumed that the input signal is ASK modulated with a minimum extinction ratio of 40 dB. The RF input is assumed to be matched to 50 ohms.
- Adjacent channel rejection is defined for an interfering tone  $\alpha_{ACR}$  [dB] above the receiving threshold and 10 MHz offset from the carrier giving a 3 dB reduction in sensitivity.

---

---

## Functional Description

The RX3400 ASK receiver IC incorporates an LNA; mixer; PLL-based local oscillator including VCO, fixed divider ( $\div 64$ ), reference crystal oscillator, phase-frequency detector (PFD), and charge pump; IF filter; logarithmic amplifier; data filter; peak detector; and 1-bit comparator and is capable of demodulating ASK input signals.

### PLL Power-down Function

The PLL portion of the IC can be powered up and down through the control of the PD input (pin 14). During PLL power down operation, the reference crystal oscillator, fixed VCO divider, PFD, and charge pump are all shut off and the current consumption of the IC drops by approximately 600  $\mu\text{A}$ . The VCO circuitry remains on and may be configured to operate as a buffer amplifier for an external SAW-based oscillator.

### 1-bit Comparator

The integrated 1-bit comparator operates as a data slicer and “squares up” the data filtered RSSI output from the logarithmic amplifier. The decision threshold voltage level for the 1-bit comparator is stored on an external capacitor connected to the ASKREF pin.

EEPW.com.cn 电子產品世界

**Application Circuit**

434 MHz

