

PAD	CONNECTION	PAD	CONNECTION
1	Supply (VDD)	6	Ground
2	Frequency output (CLKOUT)	7	Interrupt output (/INT)
3	Not connected	8	Not connected
4	Serial clock input (SCL)	9	Not connected
5	Data (SDA)	10	FOUT output enable (CLKOE)

Scale 3:1

## Features

- ▶ Equivalent to Epson *RX-8564CF*
- ▶ Compliant with I<sup>2</sup>C-Bus interface (400kHz)
- ▶ Built in crystal for adjustment-free operation
- ▶ Programmable alarm, timer and interrupt
- ▶ Low power consumption, low ageing

## Block Diagram

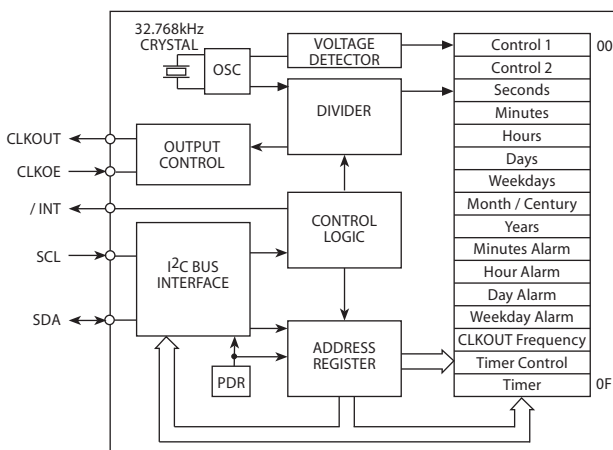

## Specifications

Parameters	Product	Option Codes
	RV8564C2	
<b>Frequencies (selectable):</b> 32.768kHz, 1024Hz, 32Hz & 1Hz	■	
<b>Frequency tolerance:</b> ±10ppm ±20ppm Other	□ ■ □	A B specify
<b>Turnover temperature (T<sub>0</sub>):</b> +25°C ±5°C	■	
<b>Frequency / temp coefficient:</b> -0.035ppm/°C <sup>2</sup> ±10%	■	
<b>Operating temperature range:</b> -40 to +85°C	■	
<b>Storage temperature range:</b> -55 to +125°C	■	
<b>Supply voltage (V<sub>DD</sub>):</b> I <sup>2</sup> C bus active 1.8 ~ 5.5V	■	
<b>Data holding voltage (V<sub>DD</sub>):</b> 1.2 ~ 5.5V	■	
<b>Supply current (during access):</b> 200µA max (f <sub>scl</sub> =100kHz) 800µA max (f <sub>scl</sub> =400kHz)	■ ■	
<b>Supply current (backup mode):</b> 275nA typ (f <sub>scl</sub> =0Hz, V <sub>DD</sub> =3V) 250nA typ (f <sub>scl</sub> =0Hz, V <sub>DD</sub> =2V)	■ ■	
<b>Start up time:</b> 3s max	■	
<b>Ageing:</b> ±3ppm max first year	■	
<b>Shock and vibration resistance:</b> ±5ppm, 5,000g, 0.3ms, sine ±5ppm, 20g, 10.0 ~ 2,000Hz	■ ■	
<b>Soldering condition:</b> Reflow, 260°C, 20 sec max	■	

■ Standard. □ Optional - Please specify required code(s) when ordering

## Ordering Information

Product + option code

eg: *RV8564C2/B* ±20ppm

Option code X (eg *RV8564C2/X*) denotes a custom spec.

- ◆ Available on T&R - 1k, 2.5k or 5k pcs per reel.
- ◆ Refer to our website for T&R and soldering details.
- ◆ The I<sup>2</sup>C-Bus is a trademark of Philips Electronics NBV