

# *Application Manual*

**Real Time Clock Module**

**RTC-58321/ 58323**

**EEPW** 电子產品世界  
www.eepw.com.cn



**SEIKO EPSON CORPORATION**



產品世界  
.com.cn

*In pursuit of "Saving" Technology, Epson electronic devices  
Our Lineup of semiconductors, Liquid crystal displays and quartz devices  
assists in creating the products of our customers' dreams.  
**Epson IS energy saving.***

### **NOTICE**

- No part of this material may be reproduced or duplicated in any form or any means without the written permission of Seiko Epson.*
- Seiko Epson reserves the right to make changes to this material without notice.*
- Seiko Epson does not assume any liability of any kind arising out of any inaccuracies contained in this material or due to its application or use in any product or circuit and, further, there is no representation that this material is applicable to products requiring high level reliability, such as, medical products.*
- Moreover, no license to any intellectual property rights is granted by implication or otherwise, and there is no representation or warranty that anything made in accordance with this material will be free from any patent or copyright infringement of a third party.*
- This material or portions thereof may contain technology or the subject relating to strategic products under the control of the Foreign Exchange and Foreign Trade Control Law of Japan and may require an export license from the Ministry of International Trade and Industry or other approval from another government agency.*

# CONTENTS

■ Overview .....	1
■ Features .....	1
■ Pin connections .....	1
■ Block diagram .....	1
■ Pin functions .....	1
■ Characteristics .....	1
1. Absolute maximum ratings .....	1
2. Operating Conditions .....	1
3. Frequency characteristics .....	1
4. DC characteristics .....	1
5. AC characteristics .....	1
6. Timing chart .....	1
7. Data hold timing .....	1
■ Registers .....	1
1. Register table .....	1
2. Notes .....	1
■ Register functions .....	1
1. Date and time registers .....	1
2. Reset register (Control register D) .....	1
3. Reference signal (Control registers E and F) .....	1
■ Package dimensions .....	1
(1)RTC-58321 .....	7
(2)RTC-58323 .....	7
■ Marking layout .....	1
■ Application notes .....	1

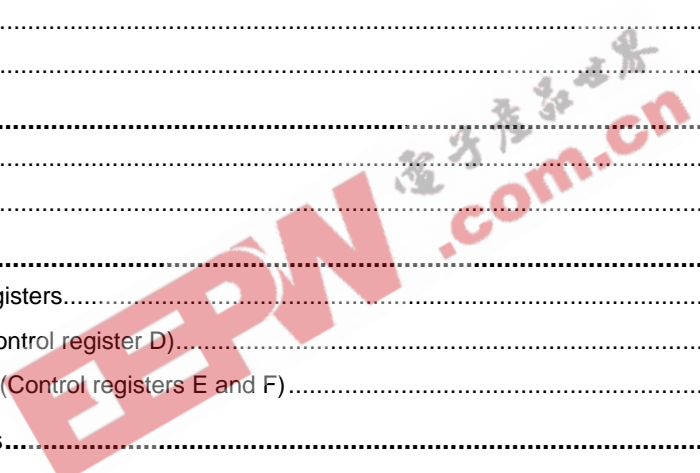

## 4BIT REAL TIME CLOCK MODULE with I/O CONNECTIONS

# RTC-58321/58323

### ■ Overview

The RTC-58321/58323 is a CMOS real time clock modules with perpetual calendar function developed for microcomputer applications.

It has a built-in 32.768 kHz quartz resonator, and provides clock and calendar registers for year, month, day, day-of-week, hours, minutes and seconds, with 12-hour/24-hour selection, plus automatic leap-year correction with software selection for local calendars, and an additional periodic reference signal output.

Being a CMOS device, it has a very low power consumption for battery back-up purposes.

### ■ Features

- Adjustment-free built-in quartz resonator keeps component count low.
- Built-in clock and calendar registers for year, month, day, day-of-week, hours, minutes and seconds.
- 12-hour/24-hour selection.
- Automatic leap-year correction, with software selection for local calendars.
- Counter start, stop and reset functions.
- Periodic reference signal output selectable: 1024 Hz, or 1 second, 1 minute or 1 hour intervals.
- Data bus is 4-bit bidirectional, with memory-type reads and writes.
- CMOS device, for very low power consumption, and long battery back-up period.
- Compatible at pin and function levels with the MSM58321 RS.

### ■ Pin connections

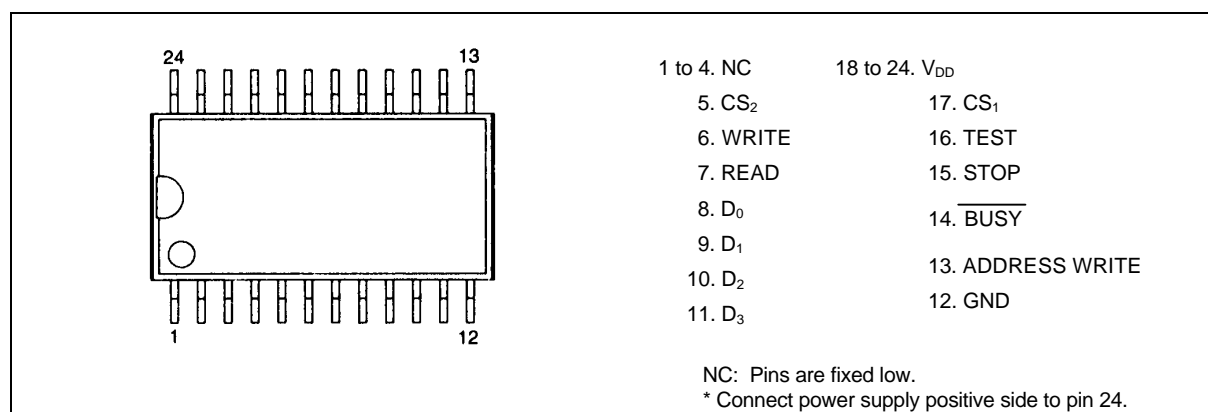
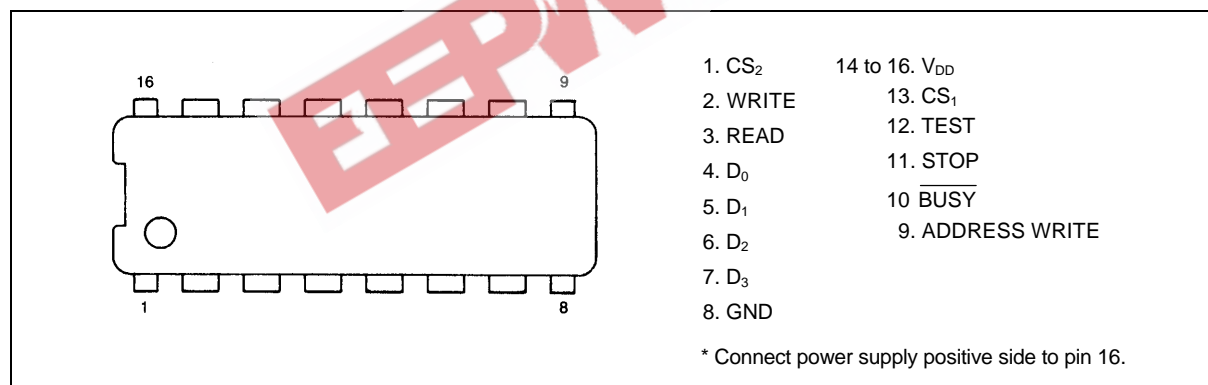

# RTC-58321/58323

## Block diagram

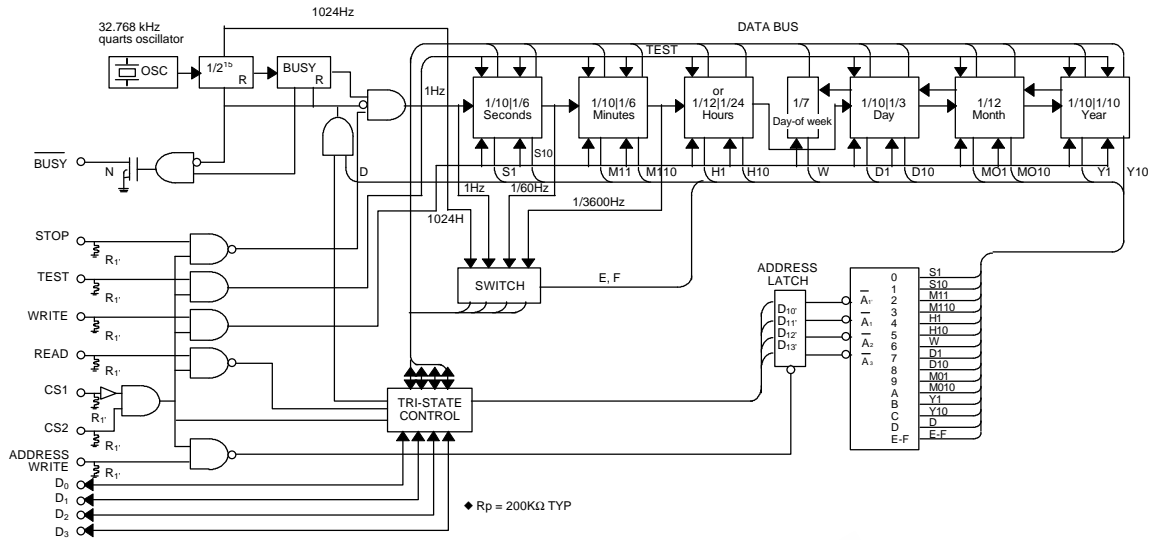

## Pin functions

Pin numbers		Pin symbol	Input/output	Function
RTC-58321	RTC-58323			
1	5	CS <sub>2</sub>	Input	Chip select. When high, device can be accessed.
2	6	WRITE	Input	Set high to write.
3	7	READ	Input	Set high to read.
4 to 7	8 to 11	D <sub>0</sub> to D <sub>3</sub>	Both	Address/data bus.
8	12	GND		Negative power supply.
9	13	ADDRESS WRITE	Input	Address latch. Set high to latch address from D <sub>0</sub> to D <sub>3</sub> .
10	14	BUSY	Output	1 Hz output pin.
11	15	STOP	Input	1 Hz on/off control pin. When high, the 1 Hz signal is disabled, and the counter stopped.
12	16	TEST	Input	Increment pin for the counter. Normally this pin should be fixed low.
13	17	CS <sub>1</sub>	Input	Connect to power down detection circuit. (Fix high if there is no power down detection circuit.) When CS <sub>1</sub> is low, chip cannot be accessed, regardless of state of CS <sub>2</sub> .
*	1 to 4	NC		Fix low.
14 to 16	18 to 24	V <sub>DD</sub>		Positive power supply (normally +5 V).

\* A bypass capacitor (minimum 0.01 μF) must be connected between V<sub>DD</sub> and V<sub>SS</sub>, as close as possible.

■ Characteristics

1. Absolute maximum ratings

Item	Symbol	Conditions (Pins)	Rated Value		Unit
Power supply voltage	$V_{DD}$	$T_a = 25^{\circ}\text{C}$ , $V_{DD}-V_{SS}$	-0.3 to +7.0		V
Input voltages	$V_I$	$T_a = 25^{\circ}\text{C}$ input pins	-0.3 to $V_{DD} + 0.3$		V
Output voltages	$V_O$	$D_0$ to $D_3$	-0.3 to $V_{DD} + 0.3$		V
Storage temperature	$T_{STG}$	Temperature stored as separate item.	RTC-58321	-55 to +85	$^{\circ}\text{C}$
			RTC-58323	-55 to +125	$^{\circ}\text{C}$
Soldering temperature	$T_{SOL}$	RTC-58321	Maximum 260 $^{\circ}\text{C}$ for up to 10 seconds (pins); package maximum 150 $^{\circ}\text{C}$ .		
		RTC-58323	Maximum 260 $^{\circ}\text{C}$ for up to 10 seconds (twice maximum), or maximum 230 $^{\circ}\text{C}$ for up to three minutes.		

2. Operating Conditions

Item	Symbol	Min.	Typ.	Max.	Unit	Notes
Power supply	$V_{DD}$	4.5	5.0	5.5	V	$V_{DD}-V_{SS}$
Data hold voltage *1	$V_{DH}$	2.2	-	5.5		
Operating temperature	RTC-58321	$T_{OP}$	-10	-	70	$^{\circ}\text{C}$
	RTC-58323		-30	-	85	

\*1 Data hold voltage: This is the range of power supply voltage for which the internal operation of the clock is guaranteed. I/O operations are not guaranteed.

3. Frequency characteristics

Item	Symbol	Conditions	Max.	Unit
Frequency tolerance	$\Delta f/f_0$	$T_a = 25^{\circ}\text{C}$ $V_{DD} = 5.0\text{V}$	$\pm 10$	ppm
			$\pm 50$	
			$5 \pm 20$	
Aging	$f_a$	$T_a = 25^{\circ}\text{C}$ : $V_{DD} = 5.0\text{V}$ ; first year	$\pm 5$	ppm/y
Temperature characteristics *2	$t_{OP}$	$V_{DD} = 5.0\text{V}$ ; $T_a = -10$ to $70^{\circ}\text{C}$	+ 10/-120	ppm
Voltage characteristics	$f_V$	$V_{DD} = 2.2$ to $5.5\text{V}$ $T_a$ fixed, 5V reference	$\pm 2$	ppm

\*2 Deviation from the frequency at 25 $^{\circ}\text{C}$ .

Notes 1. Frequency tolerance based on  $V_{DD} = 5.0\text{V}$ .  
2. Frequency tolerance is value guaranteed on factory shipment.

# RTC-58321/58323

## 4. DC characteristics

RTC-58321 ( $V_{DD} = 5V \pm 0.5V$ ,  $T_a = -10$  to  $70^\circ\text{C}$ )  
 RTC-58323 ( $V_{DD} = 5V \pm 0.5V$ ,  $T_a = -30$  to  $85^\circ\text{C}$ )

Item	Symbol	Conditions	Min.	Typ.	Max.	Unit	
High input voltage	$V_{IH1}$ *1		3.6			V	
	$V_{IH2}$ *2		$V_{DD} - 0.5$			V	
Low input voltage	$V_{IL}$				0.8	V	
Low output voltage	$V_{OL}$	$I_{OL} = 1.6\text{mA}$			0.4	V	
Low output current	$I_{OL}$	$V_{OL} = 0.4\text{V}$	1.6			mA	
High input current	$I_{IH}$ *3	$V_{IH} = 5\text{V}$	10	30	80	$\mu\text{A}$	
Low input current	$I_{IL}$ *3	$V_{IL} = 0\text{V}$			-1	$\mu\text{A}$	
Input leakage current	$I_{LIH}$	$V_{IH} = 5\text{V}$			1	$\mu\text{A}$	
Input off-state leakage current	$I_{LIL}$	$V_{IL} = 0\text{V}$			-1	$\mu\text{A}$	
Input capacity	$C_I$	$f = 1\text{MHz}$		5		pF	
Current consumption	$I_{OP}$	$V_{DD} = 5\text{V}$	*4		100	500	$\mu\text{A}$
			*5		20	40	
		$V_{DD} = 3\text{V}$	*4		15	30	
			*5		7	20	
Oscillation start time *6	$t_{OSC}$	$V_{DD} = 5\text{V}$ $T_a = 25^\circ\text{C}$		1.5	3.0	sec.	

\*1 Pins CS<sub>2</sub>, WRITE, READ, ADDRESS WRITE, STOP, TEST and D<sub>0</sub> to D<sub>3</sub>

\*2 CS<sub>1</sub>

\*3 Pins CS<sub>1</sub>, CS<sub>2</sub>, WRITE, READ, ADDRESS WRITE, STOP and TEST

\*4 CS<sub>1</sub> and CS<sub>2</sub> high,  $\overline{\text{BUSY}}$  Open-circuit

\*5 CS<sub>1</sub>, CS<sub>2</sub> and  $\overline{\text{BUSY}}$  Open-circuit

\*6 Confirmed by  $\overline{\text{BUSY}}$

## 5. AC characteristics

RTC-58321 ( $V_{DD} = 5V \pm 0.5V$ ,  $T_a = -10$  to  $70^\circ\text{C}$ )  
 RTC-58323 ( $V_{DD} = 5V \pm 0.5V$ ,  $T_a = -30$  to  $85^\circ\text{C}$ )

Item	Symbol	Conditions	Min.	Typ.	Max.	Unit
Chip select set-up time	$t_{CS}$	–	0	–	–	$\mu\text{S}$
Address set-up time	$t_{AS}$	–	0	–	–	$\mu\text{S}$
Address write pulse width	$t_{AW}$	–	0.5	–	–	$\mu\text{S}$
Address hold time	$t_{AH}$	–	0.1	–	–	$\mu\text{S}$
Data set-up time	$t_{DS}$	–	0	–	–	$\mu\text{S}$
Write pulse width	$t_{WW}$	–	2	–	–	$\mu\text{S}$
Data hold time	$t_{DH}$	–	0	–	–	$\mu\text{S}$
Read inhibit time	$t_{RI}$	–	0	–	–	$\mu\text{S}$
Read access time	$t_{RA}$	–	–	–	*	$\mu\text{S}$
Read delay time	$t_{DD}$	–	–	–	1	$\mu\text{S}$
Chip select hold time	$t_{CH}$	–	0	–	–	$\mu\text{S}$

$$* \quad t_{RA} = 1\mu\text{S} + C \times R \times \ln \frac{V_{DD}}{V_{DD} - V_{H\min}}$$

C : capacitance of data line

R : pull-up resistance

$V_{H\min}$  : high voltage level of IC connected to data line

ln : natural logarithm

6. Timing chart

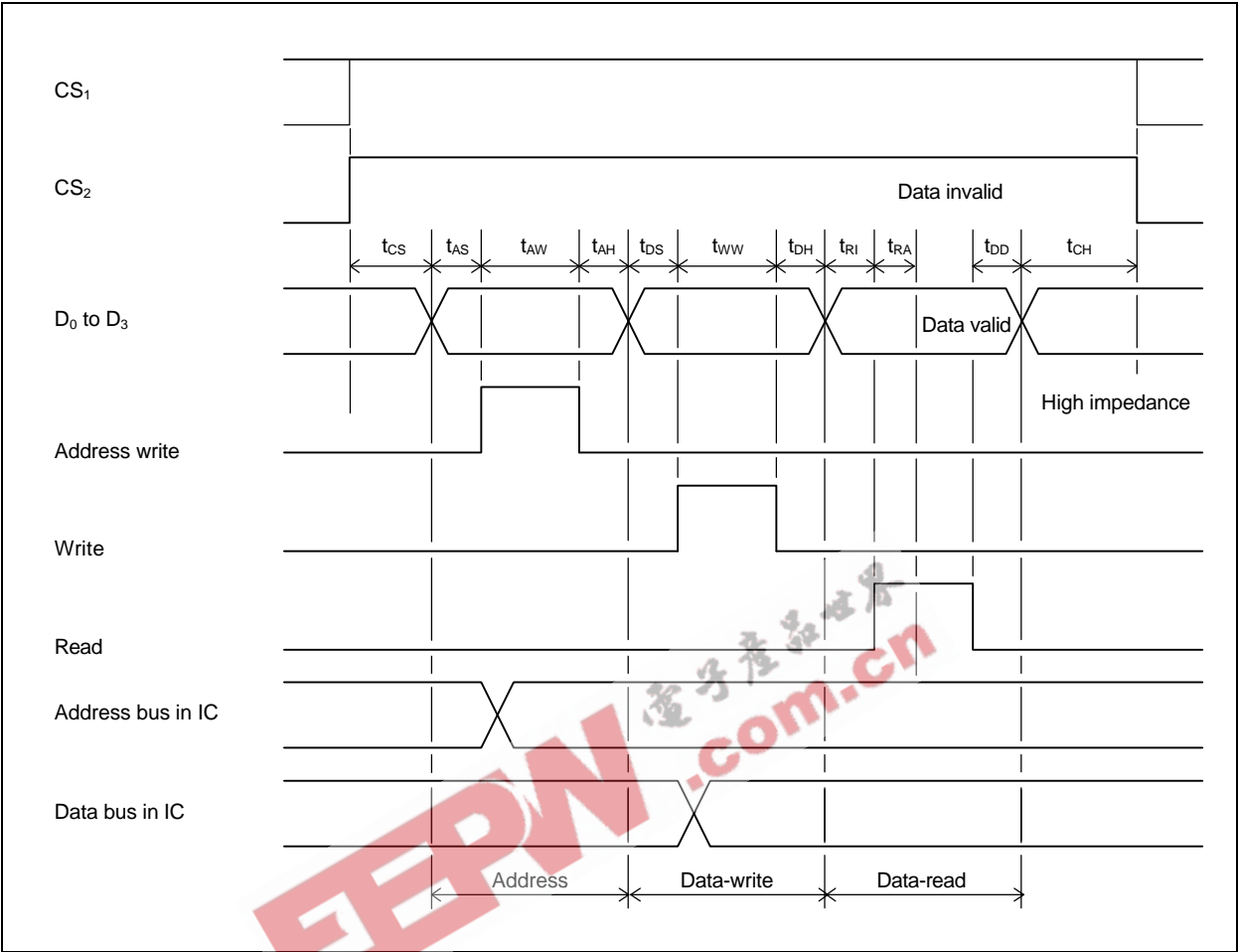

7. Data hold timing

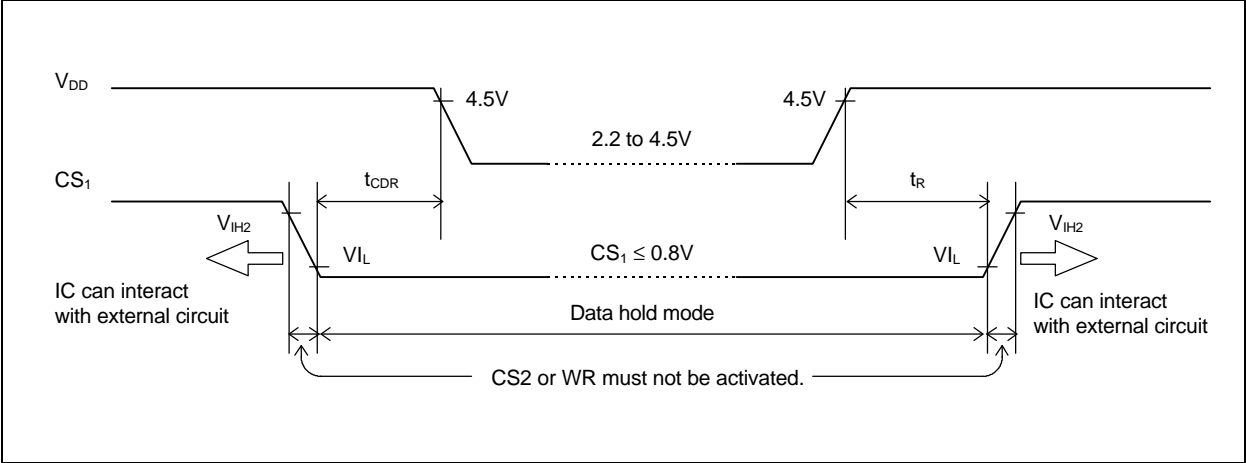



# RTC-58321/58323

## Registers

### 1. Register table

Address (hexadecimal)	D <sub>3</sub> (A <sub>3</sub> )	D <sub>2</sub> (A <sub>2</sub> )	D <sub>1</sub> (A <sub>1</sub> )	D <sub>0</sub> (A <sub>0</sub> )	Register name	DATA				Count value	Notes
						D <sub>3</sub>	D <sub>2</sub>	D <sub>1</sub>	D <sub>0</sub>		
0	0	0	0	0	S <sub>1</sub>	s <sub>8</sub>	s <sub>4</sub>	s <sub>2</sub>	s <sub>1</sub>	0 to 9	Seconds units register
1	0	0	0	1	S <sub>0</sub>	*	s <sub>40</sub>	s <sub>20</sub>	s <sub>10</sub>	0 to 5	Seconds tens register
2	0	0	1	0	M <sub>1</sub>	mi <sub>8</sub>	mi <sub>4</sub>	mi <sub>2</sub>	mi <sub>1</sub>	0 to 9	Minutes units register
3	0	0	1	1	M <sub>10</sub>	*	mi <sub>40</sub>	mi <sub>20</sub>	mi <sub>10</sub>	0 to 5	Minutes tens register
4	0	1	0	0	H <sub>1</sub>	h <sub>8</sub>	h <sub>4</sub>	h <sub>2</sub>	h <sub>1</sub>	0 to 9	Hours units register
5	0	1	0	1	H <sub>10</sub>	24/12	pm/am	h <sub>20</sub>	h <sub>10</sub>	0 to 1 or 0 to 2	Hours tens register
6	0	1	1	0	W	*	w <sub>4</sub>	w <sub>2</sub>	w <sub>1</sub>	0 to 6	Day-of-week register
7	0	1	1	1	D <sub>1</sub>	d <sub>8</sub>	d <sub>4</sub>	d <sub>2</sub>	d <sub>1</sub>	0 to 9	Day units register
8	1	0	0	0	D <sub>10</sub>	Leap year select		d <sub>20</sub>	d <sub>10</sub>	0 to 3	Day tens register
9	1	0	0	1	MO <sub>1</sub>	mo <sub>8</sub>	mo <sub>4</sub>	mo <sub>2</sub>	mo <sub>1</sub>	0 to 9	Month units register
A	1	0	1	0	MO <sub>10</sub>	*	*	*	mo <sub>10</sub>	0 to 1	Month tens register
B	1	0	1	1	Y <sub>1</sub>	y <sub>8</sub>	y <sub>4</sub>	y <sub>2</sub>	y <sub>1</sub>	0 to 9	Year units register
C	1	1	0	0	Y <sub>10</sub>	y <sub>80</sub>	y <sub>40</sub>	y <sub>20</sub>	y <sub>10</sub>	0 to 9	Year tens register
D	1	1	0	1		*	*	*	*		Reset register
E	1	1	1	0		1hour	1minute	1second	1024Hz		Reference signal registers
F	1	1	1	1							

### 2. Notes

- The device uses positive logic, and a logic high voltage corresponds to a 1 in a register bit.
- Do not set the clock to impossible dates (17:34 pm on February 30th, for example). The results are unpredictable.
- When the device is powered on, the initial settings of all bits are undefined.

## Register functions

### 1. Date and time registers

- The register values are in BCD, and used positive logic.  
E.g.(S<sub>8</sub>, S<sub>4</sub>, S<sub>2</sub>, S<sub>1</sub>) = (1, 0, 0, 1) = 9 seconds

- Day-of-week register  
The value is coded as 0 to 6, with Sunday = 0.

Code	0	1	2	3	4	5	6
Day	Sun.	Mon.	Tue.	Wed.	Thu.	Fri.	Sat.

- pm/am, h<sub>20</sub> and h<sub>10</sub> registers  
The range of these values depends on whether the 12-hour or 24-hour clock is being used.  
The pm/am bit is used only when the 12-hour clock is selected.  
Set D<sub>3</sub> to 1 for the 24-hour, and to 0 for the 12-hour clock.  
Set D<sub>2</sub> to 1 for pm and to 0 for am. Writing a 1 to bit D<sub>3</sub> automatically resets bit D<sub>2</sub> to 0.

Selection	Value range
12-hour clock	12:00 to 11:59 am and pm *
24-hour clock	00:00 to 23:59

\* Note: 12:00 am represents 12:00 midnight, and 12:00 pm represents 12:00 noon.

- Y<sub>1</sub> and Y<sub>10</sub> Leap year selection  
Bits D<sub>3</sub> and D<sub>2</sub> of the day tens register select the year value module 4 to be used for leap years.

Calendar	D <sub>3</sub>	D <sub>2</sub>	Value module 4 for leap year
Standard calendar	0	0	0
	0	1	3
	1	0	2
	1	1	1

- Do not set the clock to impossible dates (17:34 pm on February 30th, for example). The results are unpredictable.

2. Reset register (Control register D)

Select this register to reset the last five stages of the  $1/2^{15}$  divider, and the busy circuit.  
Latch the hexadecimal value D using the ADDRESS LATCH pin, and set WRITE high to carry out the reset.

3. Reference signal (Control registers E and F)

Latch the hexadecimal value E or F using the ADDRESS LATCH pin, and set WRITE high to obtain the reference signal values on D<sub>0</sub> to D<sub>3</sub>.

■ Package dimensions

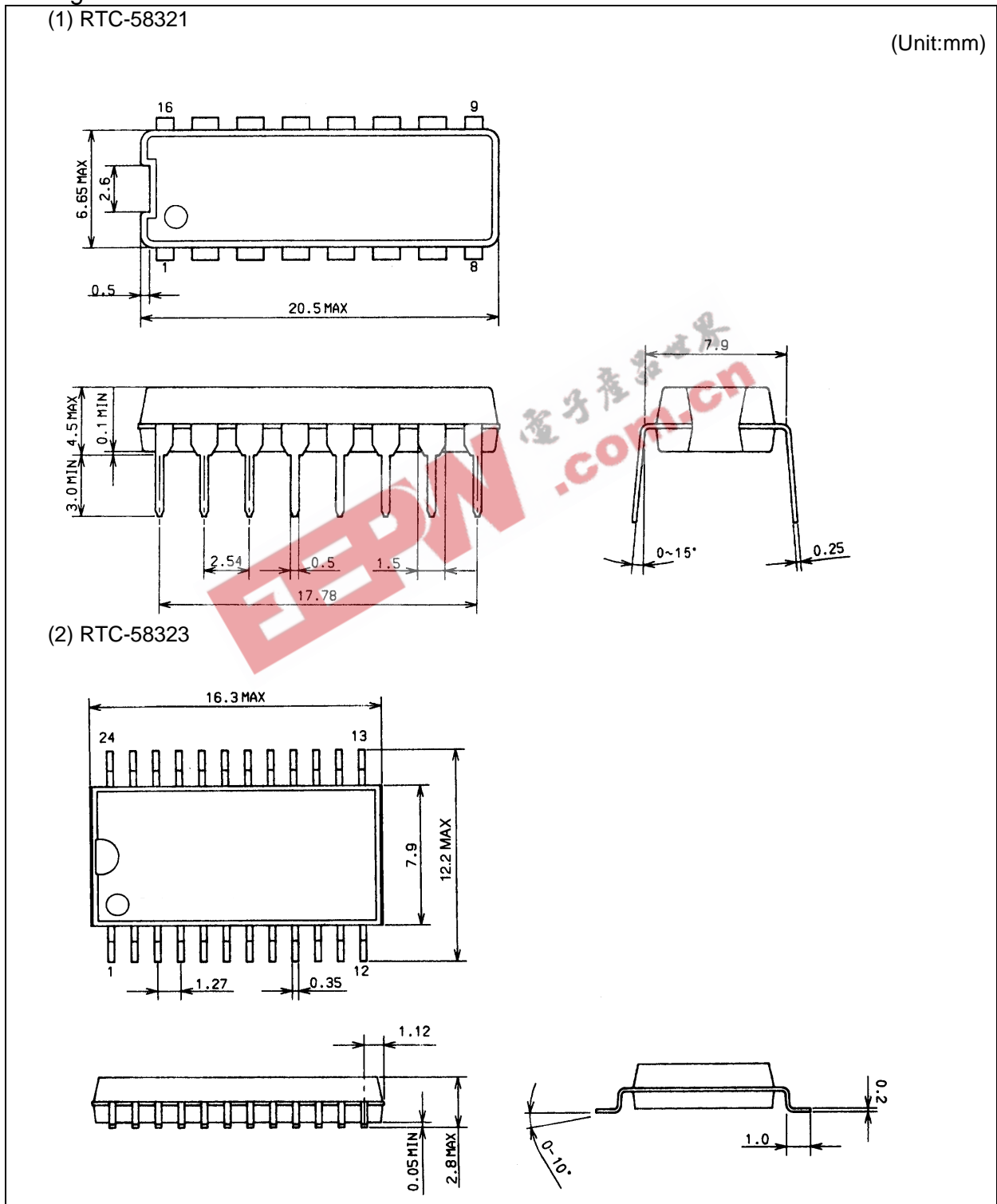

# RTC-58321/58323

## ■ Marking layout

Type	Indication	Tolerances
RTC-58321	A	±10 ppm
	B	±50 ppm
RTC-58323		5 ±20 ppm

Note: The illustration is a general representation of the content and the location of information on the label, and is not a detailed specification of the typeface, size or positioning of printing used on the label.

## ■ Application notes

- (1) In order to realize low-power operation, the device has a high impedance; the shaded portion in the figure below is highly susceptible to inductance effects, and should be kept clear of signal lines.

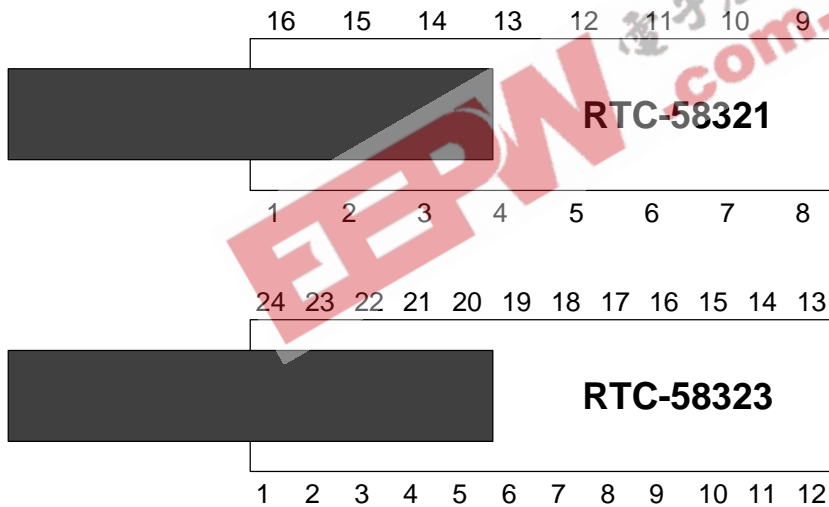

- (2) Power supply filter capacitor  
To ensure stable operation against transients and noise, connect a bypass capacitor of at least 0.01 μF (ceramic) across the power supply, close to the device.
- (3) This device passes a drop test (from 75 cm onto a hard board), but it is possible for the crystal resonator to be damaged by the shocks produced by some mounting equipment. It is important to confirm that the mounting conditions for the equipment being used do not adversely affect performance. Re-check if any of the mounting conditions change.
- (4) There is a possibility of damage to the crystal resonator during ultrasonic cleaning. Because of the wide variation of conditions in ultrasonic cleaning equipment, the performance of this device is not guaranteed if it is subject to ultrasonic cleaning.
- (5) This is a CMOS device, and the standard precautions against static electricity should be taken.

# EPSON

## Application Manual

# RTC-58321/ 58323

Distributor

### AMERICA

EPSON AMERICA, INC.

20770 Madrona Avenue Torrance, CA 90503 2842 U.S.A  
Phone: (310) 310-782-0770 Fax: (310) 310-782-5320

### EUROPE

EPSON EUROPE ELECTRONICS GmbH

Flessstrasse 15, 80992 München GERMANY  
Phone: (49)-(0)89-14005-0 Fax: (49)-(0)89-14005-110

EPSON EUROPE ELECTRONICS UK Office

G6 Doncastle House, Doncastle Road, Bracknell, Berkshire, RG12 8PE, England  
Phone: (41)-(0)1-344-381700 Fax: (41)-(0)1-344-381701

EPSON EUROPE ELECTRONICS FRANCE Office

Les Conquerants Immeuble "Rijhams", L.P. 915 1 Avenue de l'Atlantique, Z.A. de Courtaboeuf 2, 91976 Les Ulis Cedex  
Phone: (33)-(0)1-64-86-23-50 Fax: (33)-(0)1-64-86-23-55

EPSON ITALIA S.P.A.

V.le Fill Casiraghi, 427 20099 Sesto San Giovanni, Milan, ITALY  
Phone: (39) 2-262331 Fax: (39) 2-2440750

### ASIA

EPSON HONG KONG LTD.

20/F., Harbour Centre, 25 Harbour Road, Wanchai, HONG KONG  
Phone: (852) 2585-4600 Fax: (852) 2527-2132

EPSON TAIWAN TECHNOLOGY & TRADING LTD.

10F, No.287, NanMing East Road, Sec.3, Taipei, TAIWAN, R.O.C.  
Phone: (886) 2-717-7360 Fax: (886) 2-718-9366

EPSON SINGAPORE PTE. LTD.

No. 1, Temasek Avenue #36-00, Millenia Tower, SINGAPORE 039192  
Phone: (65) 337-7911 Fax: (65) 334-1185

SHANGHAI EPSON ELECTRONICS CO., LTD.

4F, Bldg. 27, No.69, Gulljing Road, Caohujing, Shanghai, CHINA  
Phone: (86) 21-6485-0835 Fax: (86) 21-6485-0775

SEIKO EPSON CORPORATION KOREA Office

10F, KLI 63 Building, 60 Yoido-dong, Youngdeungpo-Ku, Seoul, 150-010, KOREA  
Phone: (82) 2-784-6027 Fax: (82) 2-787-3677

### SEIKO EPSON CORPORATION

ELECTRONIC DEVICE MARKETING DEPARTMENT

Electronic devices information on WWW server

<http://www.epson.co.jp>