

INTRODUCTION

The S1T8515A is designed for FM detection on the FLEX pager set. It consists of an Oscillator, Mixer, Limiting IF Amp. Quadrature Detector, Regulator, RSSI (Received Signal Strength Indicator), Bit Rate Filter, and a 2-level / 4-level FSK comparator. It has a 24-SSOP (0.65mm) Surface Mount Package.

FEATURES

- Internal A/D converter for 4 level FSK (2-bit ADC)
- High transmission rate: 6400bps (Max.)
- Operating voltage range: $V_{CC1} = 1.1 \sim 4.0V$
- Typical supply current: 1.5mA at 1.4V
- Low battery detection circuit (alarm function): 1.05V
- Mixer operating frequency: 10 ~ 50MHz
- Package type: 24-SSOP (0.65mm)

24-SSOP-BD209

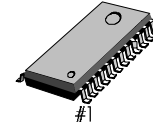

ORDERING INFORMATION

Device	Package	Operating Temperature
S1T8515A01-U0B0	24-SSOP-BD209	-20°C ~ +70°C

BLOCK DIAGRAM

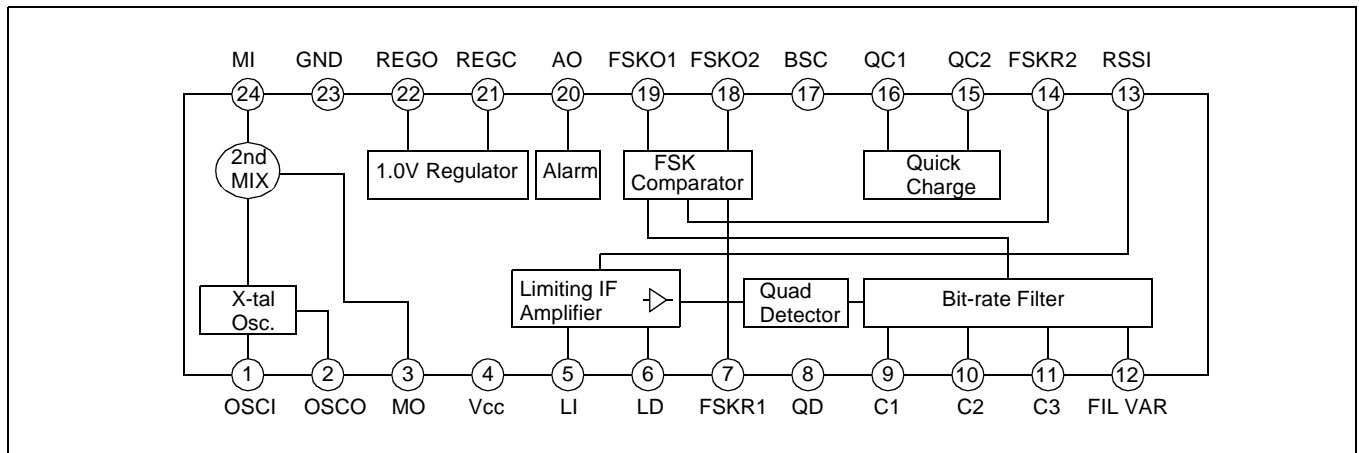

PIN CONFIGURATION

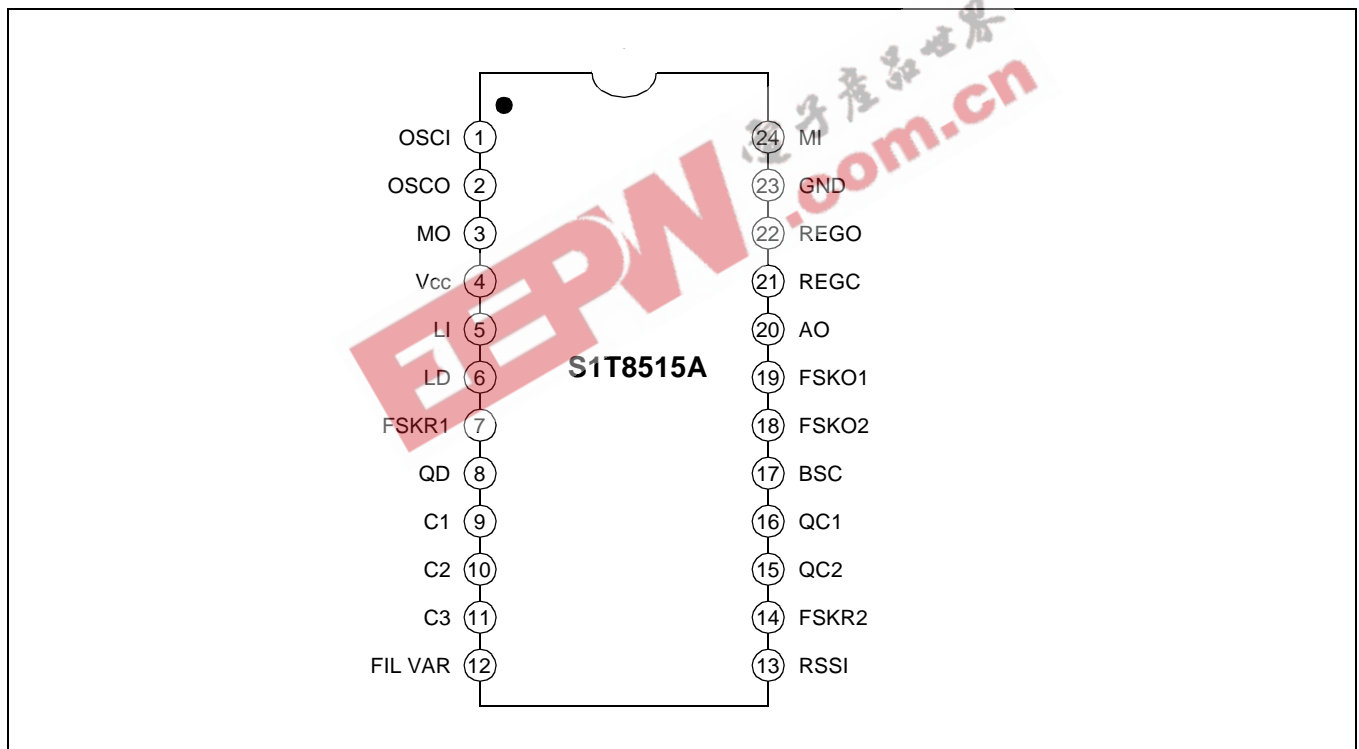

PIN DESCRIPTION

Pin No	Symbol	Description
1	OSCI	Oscillator input (Base). The oscillator is an internally biased colpitts type.
2	OSCO	Oscillator output (Emitter).
3	MO	Mixer output (Output impedance $\approx 1.5k\Omega$) Connect a 455kHz filter between this pin and the LI.
4	V _{CC}	Power supply voltage.
5	LI	IF limiter amplifier input (Input impedance $\approx 1.5k\Omega$).
6	LD	Bypass capacitor connect pin for the IF limiter amp.
7	FSKR1	Differential Amp Reference input on the FSK comparator.
8	QD	Quadrature detection, phase shifter input.
9 10 11	C1 C2 C3	Capacitors for bit-rate filter.
12	FIL VAR	Bit-rate filter selection. High: Internal cut-off frequency will be set to Low. Low: Internal cut-off frequency will be set to High.
13	RSSI	RSSI output. The power of received RF signal can be detected by monitoring the limiter amplifier.
14	FSKR2	Differential Amp Reference input on the FSK comparator for 4-Level FSK Detection.
15, 16	QC2, QC1	Quick charge control 2 & 1. High: Quick charge-discharge on. Low: Quick charge-discharge off.
17	BSC	Battery saving control. High: Battery saving off-normal mode operation. Low: Battery saving on-battery save mode operation.
18	FSKO2	The output signal from the Bit-rate filter is compared with FSK Reference signal, and the final output signal will be output to the LSB after 4-Level FSK detection.
19	FSKO1	The final output signal will be output to the MSB after 4-Level FSK detection.
20	AO	Alarm output. This pin becomes high, when V _{CC} drops below 1.05V.
21	REGC	S1T8515A has an internal PNP transistor. But, it also can support an external PNP transistor to control the power.
22	REGO	Regulated voltage output.
23	GND	Ground.
24	MI	Mixer input (Input impedance $\approx 1.5k\Omega$).

ABSOLUTE MAXIMUM RATINGS

Characteristic	Symbol	Value	Unit
Supply Voltage	V_{CC} (MAX)	4	V
Power Dissipation	P_D	760	mW
Operating Temperature	T_{OPR}	-20 — +70	°C
Storage Temperature	T_{STG}	-55 — +125	°C

ELECTRICAL CHARACTERISTICS

($V_{CC} = 1.4V \pm 5\%$, f_{IN} (2MIX) = 21.4MHz, $f_{DEV} = \pm 4.8kHz$, $f_{MOD} = 800Hz$, $T_a = 25^\circ C$, FIL_VAR = 'H', unless otherwise specified)

Characteristic	Symbol	Test Conditions	Min.	Typ.	Max.	Unit
Operating current	I_{CCN}	No Input Signal	–	1.5	1.75	mA
	I_{CCS}	Battery Saving	–	0	10	μA
Alarm detection voltage	V_{AD}	–	1.0	1.05	1.1	V
Alarm low level output voltage	V_O (AL)	$I = 100\mu A$	–	–	0.4	V
Alarm high level leakage current	I_{LKG} (AL)	–	–	–	2	μA
FSK low level output voltage	V_L (FSK)	$I = 100\mu A$	–	–	0.4	V
FSK high level leakage current	I_{LKG} (FSK)	–	–	–	2	μA
Regulator output voltage	V_{OREG}	–	0.95	1.0	1.05	V
Quick charge current	I_C	–	50	70	–	μA
Input for –3dB sensitivity	V_{LIM}	Mixer Input	–	2.5	7.5	μV_{rms}
Recovered audio output voltage	V_O (RAO)	V_{IN} (2MIX) = 500 μV_{rms}	36	54	78	mV $_{rms}$
Mixer conversion gain	ΔG_V (M)	Ceramic Filter loss = –1dB	8	12	16	dB
Signal to noise ratio	S/N	V_{IN} (MIX1N) = 500 μV_{rms}	38	55	–	dB
Total Harmonic Distortion	THD	V_{IN} (MIX1N) = 500 μV_{rms}	–	2.0	3.5	%
Mixer 3rd order intercept point	3RD	–	–	–10	–	dBm
Mixer input resistance	R_I (MIX)	–	3.5	5	6.5	k Ω
Limiting amp input resistance	R_I (LA)	–	0.9	1.5	2.1	k Ω
AM rejection ratio	AMR	V_{IN} (2MIX) = 500 μV_{rms} (AM = 300%)	25	40	–	dB
Data shaping output duty	DR	V_{IN} (2MIX) = 500 μV_{rms}	40	50	60	%
RSSI output voltage	V_{RSSI}	V_{IN} (2MIX) = 1mV $_{rms}$	0.49	0.7	0.91	V
RSSI output resistance	R_{RSSI}	–	90	100	110	k Ω

TEST CIRCUIT

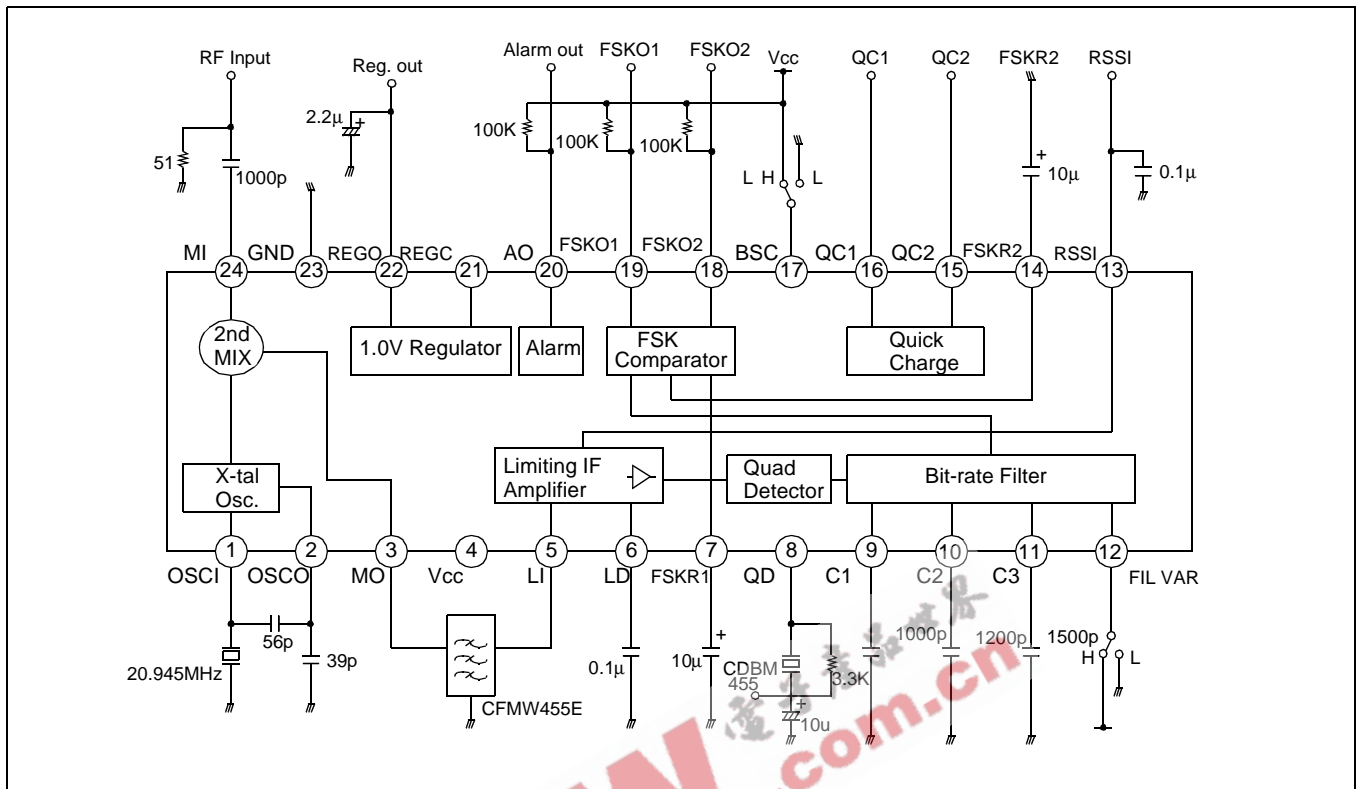

NOTES

EEPW 电子产品世界
.com.cn