

S1PDB72

Single Phase Bridge Rectifiers Modules

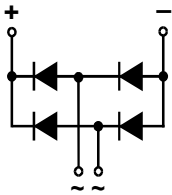
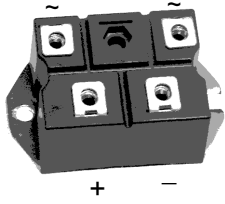

Type	V _{RSM} V	V _{RRM} V
S1PDB72N08	900	800
S1PDB72N10	1100	1000
S1PDB72N12	1300	1200
S1PDB72N14	1500	1400
S1PDB72N16	1700	1600
S1PDB72N18	1900	1800

Dimensions in mm (1mm=0.0394")

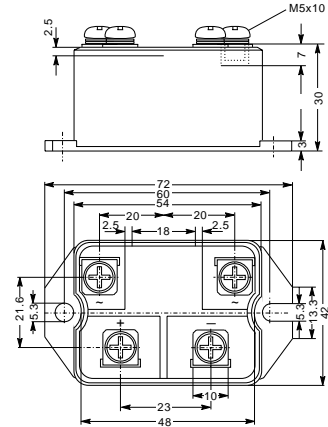

Symbol	Test Conditions	Maximum Ratings	Unit	
I _{dav}	T _C =100°C, module	72	A	
I _{dav}	T _A =45°C (R _{thCA} =0.6K/W), module	49		
I _{FSM}	T _{VJ} =45°C V _R =0 t=10ms (50Hz), sine	750	A	
	T _{VJ} =T _{VJM} V _R =0 t=8.3ms (60Hz), sine	820		
I ² t	T _{VJ} =45°C V _R =0 t=10ms (50Hz), sine	670	A ² s	
	T _{VJ} =T _{VJM} V _R =0 t=8.3ms (60Hz), sine	740		
T _{vj} T _{vjm} T _{stg}		2800		°C
		2800		
V _{ISOL}	50/60Hz, RMS I _{ISOL} ≤ 1mA	2500	V~	
		3000		
M _d	Mounting torque (M5)	5 ± 15%	Nm	
	Terminal connection torque (M5)	5 ± 15%		
Weight	typ.	160	g	

S1PDB72

Single Phase Bridge Rectifiers Modules

Symbol	Test Conditions	Characteristic Values	Unit
I_R	$V_R=V_{RRM}; T_{VJ}=25^{\circ}\text{C}$ $V_R=V_{RRM}; T_{VJ}=T_{VJM}$	≤ 0.3 ≤ 5	mA
V_F	$I_F=150\text{A}; T_{VJ}=25^{\circ}\text{C}$	≤ 1.6	V
V_{TO}	For power-loss calculations only	0.8	V
r_T	$T_{VJ}=T_{VJM}$	5	$\text{m}\Omega$
R_{thJC}	per diode per module	1.1 0.183	K/W
R_{thJK}	per diode per module	1.52 0.253	K/W
d_s	Creeping distance on surface	10	mm
d_A	Creepage distance in air	9.4	mm
a	Max. allowable acceleration	50	m/s^2

FEATURES

- * Package with screw terminals
- * Isolation voltage 3000 V~
- * Planar passivated chips
- * Blocking voltage up to 1800 V
- * Low forward voltage drop

APPLICATIONS

- * Supplies for DC power equipment
- * Input rectifiers for PWM inverter
- * Battery DC power supplies
- * Field supply for DC motors

ADVANTAGES

- * Easy to mount with two screws
- * Space and weight savings
- * Improved temperature and power cycling