

INTRODUCTION

S1T8507C is a automatic gain control system that is used for dynamic range compression and expansion.

By companding the signal , this can reduce the noise components.

S1T8507C includes compressor, expander, pre-amp, filter amp, limiter and mute/bypass logic.

FEATURES

- Wide Supply Voltage (2.4 to 7V)
- Easy Gain Control
- Mute/Bypass Logic
- Data In/Out Pin

ORDERING INFORMATION

Device	Package	Operating Temperature
S1T8507C01-D0B0	20-DIP-300A	-20°C to +70°C
S1T8507C01-S0B0	20-SOP-375	

20-DIP-300A

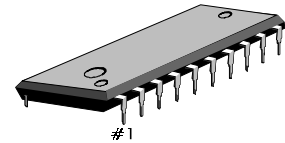

20-SOP-375

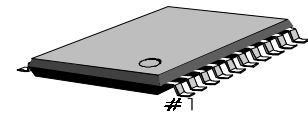

BLOCK DIAGRAM

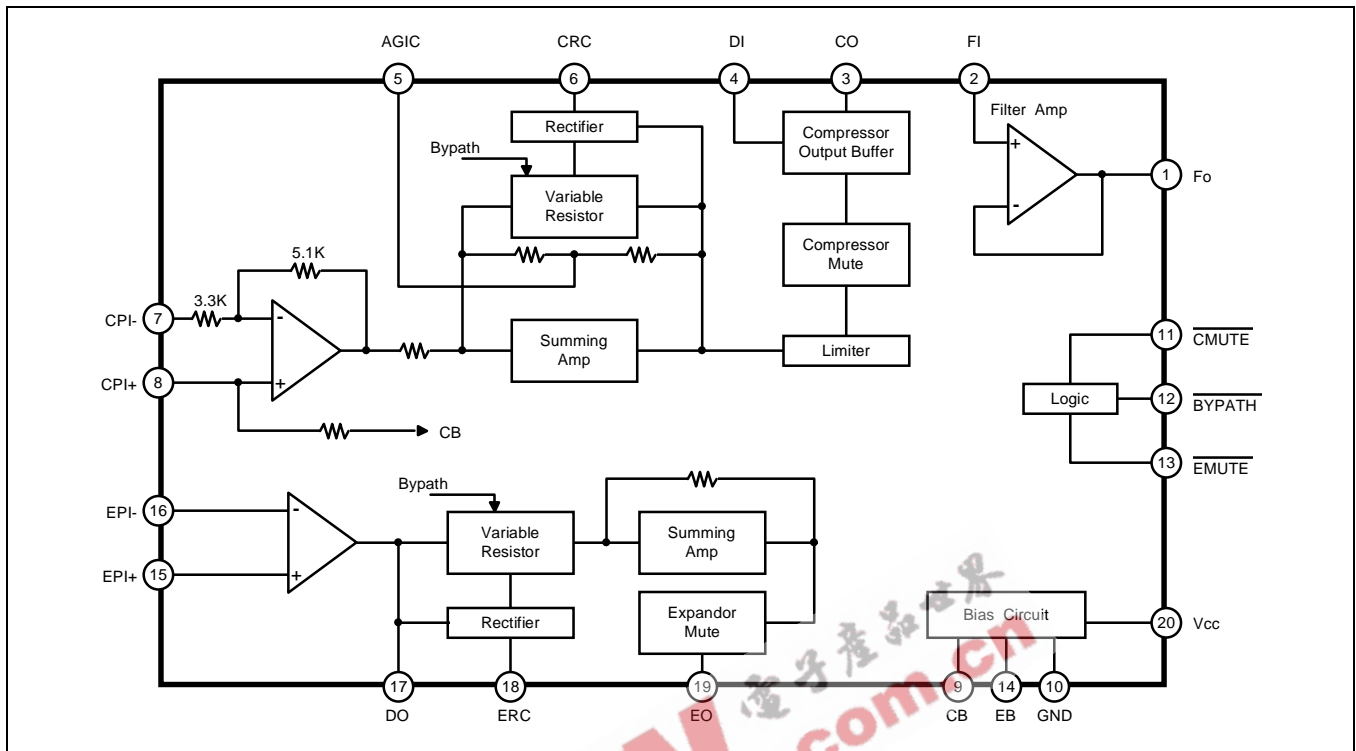

PIN CONFIGURATION

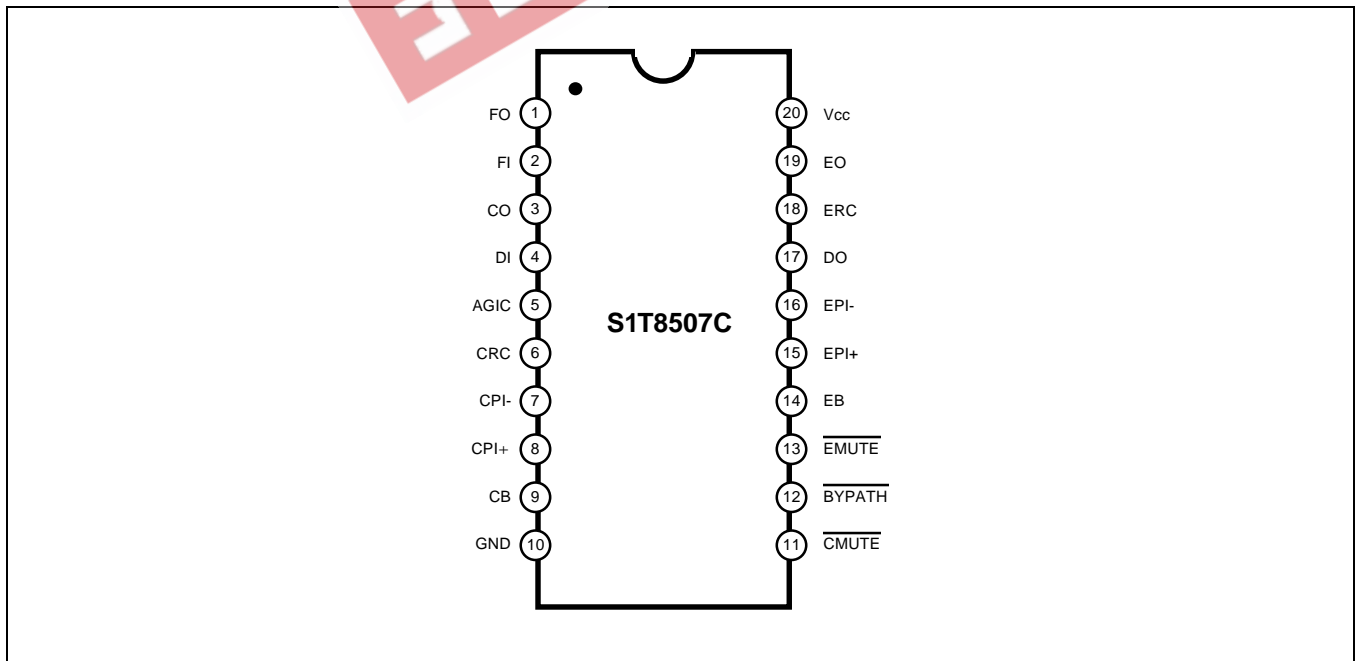

PIN DESCRIPTION

Pin No	Symbol	Description	Pin No	Symbol	Description
1	FO	Filter Amp Output	11	$\overline{\text{CMUTE}}$	Compressor Mute
2	FI	Filter Amp Input	12	$\overline{\text{BYPATH}}$	No companding
3	CO	Compressor Output	13	$\overline{\text{EMUTE}}$	Expander Mute
4	DI	Data Input	14	EB	Expander Reference Bias
5	AGIC	AC Gain Infinity Capacitor	15	EPI +	Expander Non-Inverting Input
6	CRC	Compressor Rectifier Capacitor	16	EPI -	Expander Inverting Input
7	CPI -	Compressor Inverting Input	17	DO	Data Output
8	CPI +	Compressor Non-Inverting Input	18	ERC	Expander Rectifier Capacitor
9	CB	Compressor Reference Bias	19	EO	Expander Output
10	GND	Ground	20	V _{CC}	Supply Voltage

ABSOLUTE MAXIMUM RATINGS

Characteristic		Symbol	Value	Unit
Supply Voltage		V _{CC}	10	V
Power Dissipation	S1T8507C01-D0B0	P _D	1000	mW
	S1T8507C01-S0B0		410	
Operating Temperature		T _{OPR}	- 20 to + 70	°C
Storage Temperature		T _{STG}	- 55 to + 150	°C

ELECTRICAL CHARACTERISTICS

(V_{CC} = 3V, f = 1kHz, T_a = 25°C, unless otherwise noted)

Characteristic	Symbol	Test Condition	Min.	Typ.	Max.	Unit
DC ELECTRICAL CHARACTERISTICS						
Operating Voltage	V _{CC}	–	–	2.4	7.0	V
Operating Current	I _{CC}	No Signal	–	4.0	6.5	mA
COMPRESSOR PART						
Standard Input Voltage (0dB)	V _{I (COMP)}	V _{CC} = 300mVrms = 0dB	8.0	12.5	17.0	mVrms
Gain Difference	ΔG _{V1 (COMP)}	Vin = –20dB	–0.5	0	+0.5	dB
	ΔG _{V2 (COMP)}	Vin = –40dB	–1.0	0	+1.0	
Bypass Gain Difference	ΔG _{VB (COMP)}	Vin = 0dB, BYPATH = GND	–1.5	0	+1.5	dB
Output Distortion	THD _{COMP}	Vin = 0dB	–	0.5	1.0	%
Noise Output Voltage	V _{NO (COMP)}	Rg = 620ohm	–	3.0	5.5	mVrms
Mute Attenuation Ratio	ATT _{MUTE}	Vin = 0dB, CMUTE = GND	60	80	–	dB
Limiting Voltage	V _{LIM (COMP)}	–	1.15	1.35	1.50	Vp-p
EXPANDER PART						
Standard Output Level (0dB)	V _{O (EXP)}	Vin = 30mVrms = 0dB	110	130	160	mVrms
Gain Difference	ΔG _{V1 (EXP)}	Vin = –10dB-0.5	–0.5	0	+0.5	dB
	ΔG _{V2 (EXP)}	Vin = –20dB	–1.0	0	+1.0	
	ΔG _{V3 (EXP)}	Vin = –30dB	–1.5	0	+2.0	
Bypass Gain Difference	ΔG _{VB (EXP)}	Vin = 0dB, BYPATH = GND	–2.5	0	+0.5	dB
Output Distortion	THD _{EXP}	Vin = 0dB	–	0.5	1.5	%
Noise Output Voltage	V _{NO (EXP)}	Rg = 620ohm	–	10.0	30.0	μVrms
Mute Attenuation Ratio	ATT _{MUTE}	Vin = 0dB, EMUTE = GND	60	80	–	dB
Max. Output Voltage	V _{OEXP (MAX)}	THD = 10%	700	800	–	mVrms

TEST CIRCUIT

