

Three Phase Bidirectional Power/Energy Metering IC with Instantaneous Pulse Output



sames

SA2005F

FEATURES

- Functionally compatible with the SA9105F with reduced external components
- Performs bidirectional one, two or three phase power and energy measurement
- Meets the IEC 521/1036 Specification requirements for Class 1 AC Watt hour meters
- Operates over a wide temperature range
- Uses current transformers for current sensing
- Easily adaptable to different signal levels
- Precision voltage reference on chip
- Precision oscillator on chip.
- Protected against ESD

DESCRIPTION

The SAMES SA2005F is an enhancement of the SA9105F. A precision oscillator and the loop capacitors are integrated on chip.

The SAMES SA2005F three phase bidirectional power/energy metering integrated circuit generates pulse rate outputs for positive and negative energy directions. The frequency of the pulses is proportional to the measured power consumption. The SA2005F performs active power calculation.

The method of calculation takes the power factor into account.

Energy consumption is determined by integrating the power measurement over time.

This innovative universal three phase power/energy metering integrated circuit is ideally suited for applications such as residential and industrial energy metering and control.

The SA2005F integrated circuit is available in 20 pin dual-in-line plastic (DIP-20), and 20 pin small outline (SOIC-20) package types.

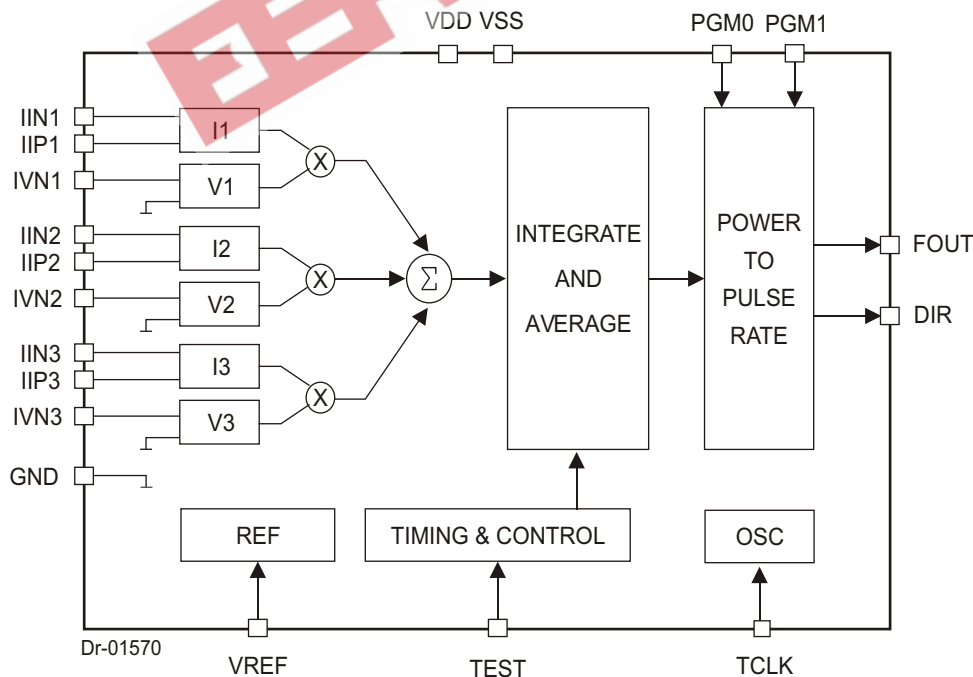

Figure 1: Block Diagram

**ELECTRICAL CHARACTERISTICS**(V_{DD} = 2.5V, V_{SS} = -2.5V, over the temperature range -10°C to +70°C[#], unless otherwise specified.)

Parameter	Symbol	Min	Typ	Max	Unit	Condition
Operating temp. Range	T _O	-25		+85	°C	
Supply Voltage	V _{DD} - V _{SS}	4.5		5.5	V	
Supply Current	I _{DD}			10	mA	Output unloaded
Nonlinearity of Power Calculation		-0.3		+0.3	%	1% - 100% of rated power
Current Sensor Inputs (Differential)						
Input Current Range	I _{II}	-25		+25	µA	Peak value
Voltage Sensor Input (Asymmetrical)						
Input Current Range	I _{IV}	-25		+25	µA	Peak value
Pins FOUT, DIR Output Low Voltage Output High Voltage	V _{OL} V _{OH}	V _{DD} -1		V _{SS} +1	V V	I _{OL} = 5mA I _{OH} = -2mA
Pulse Rate: FOUT	f _P	0		64	Hz	MODES 0, 1, 2 Specified linearity Min and Max limits
		0		200	Hz	
Pin PGM0, PGM1, TEST, TCLK	V _{IH} V _{IL}	0		1160	Hz	MODE 3 Specified linearity Min and Max Limits
		0		3500	Hz	
High Voltage	V _{IH}	V _{DD} -1			V	
Low Voltage	V _{IL}			V _{SS} +1	V	
Pin VREF						
Ref. Current	-I _R	45	50	55	µA	With R = 24k connected to V _{SS} Referred to V _{SS}
Ref. Voltage	V _R	1.1		1.3	V	

ABSOLUTE MAXIMUM RATINGS*

Parameter	Symbol	Min	Max	Unit
Supply Voltage	V _{DD} -V _{SS}	-0.3	6.0	V
Current on any pin	I _{PIN}	-150	+150	mA
Storage Temperature	T _{STG}	-40	+125	°C
Operating Temperature	T _O	-40	+85	°C

*Stresses above those listed under "Absolute Maximum Ratings" may cause permanent damage to the device. This is a stress rating only. Functional operation of the device at these or any other condition above those indicated in the operational sections of this specification, is not implied. Exposure to Absolute Maximum Ratings for extended periods may affect device reliability.

**PIN DESCRIPTION**

PIN	Designation	Description
16	GND	Analog Ground. The voltage to this pin should be mid-way between V_{DD} and V_{SS} .
6	V_{DD}	Positive Supply voltage.
14	V_{SS}	Negative Supply voltage.
17, 20, 3	IVN1, IVN2, IVN3	The current into the A/D converter should be set at $14\mu A_{RMS}$ at nominal mains voltage. The voltage sense input saturates at an input current of $\pm 25\mu A$ peak.
19, 18, 2, 1, 5, 4	IIN1, IIP1, IIN2, IIP2, IIN3, IIP3	Inputs from current sensors. The shunt resistor voltage from each channel is converted to a current of $16\mu A_{RMS}$ at rated conditions. The current sense input saturates at an input current of $\pm 25\mu A$ peak.
15	VREF	This pin provides the connection for the reference current setting resistor. A $24k$ resistor connected to V_{SS} sets the optimum operating condition.
7, 10	TCLK, TEST	Test inputs. For normal operation these pins must be connected to V_{SS} .
8	FOUT	Pulse rate output. The pulse frequency is proportional to the sum of the power measured on all three phases. The pulse format also indicates the direction of energy flow.
9	DIR	Direction output. This output indicates the direction of energy flow.
12, 13	PGM0, PGM1	FOUT Pulse format Select. These inputs define the FOUT pulse width and format.

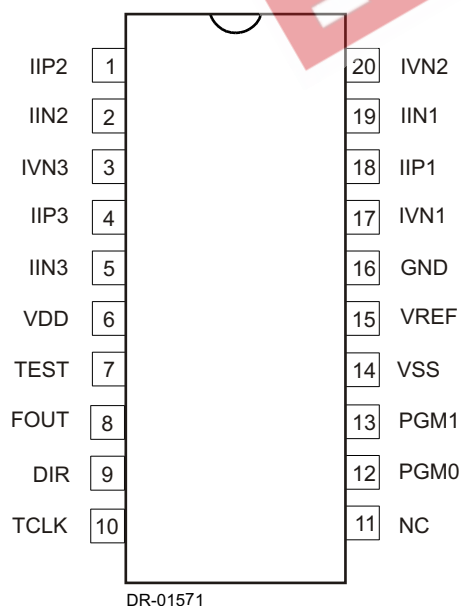
**ORDERING INFORMATION**

Part Number	Package
SA2005FPA	DIP-20
SA2005FSA	SOIC-20

Figure 2: Pin connections: Package: DIP-20, SOIC-20



FUNCTIONAL DESCRIPTION

The SAMES SA2005F is a CMOS mixed signal integrated circuit, which performs three phase power/energy calculations over a range of 1000:1, to an overall accuracy of better than Class 1.

The SA2005F is functionally similar to the SA9105F. No external loop capacitors are required and an precision oscillator is integrated on chip.

The integrated circuit includes all the required functions for 3-phase power and energy measurement such as oversampling A/D converters for the voltage and current sense inputs, power calculation and energy integration. Internal offsets are eliminated through the use of cancellation procedures.

The SA2005F generates pulses with a frequency proportional to the power measured. The pulse rate follows the instantaneous power measured. The pulse frequency is proportional to the total sum of the three phases.

POWER CALCULATION

In the application circuit (figure 5), the mains voltages from V1, V2 and V3, are converted to currents and applied to the voltage sense inputs IVP1, IVP2 and IVP3.

The current levels on the voltage sense inputs are derived from the mains voltages (3 x 230VAC) being divided down to 14V through voltage dividers. The resulting input currents into the A/D converters are 14µA_{RMS} through the resistors R8, R9 and R10.

For the current sense inputs the voltage drop across the current transformers terminating resistors are converted to currents of 16µA_{RMS} at rated conditions, by means of resistors R1, R2 (Phase 1); R3, R4 (Phase 2) and R5, R6 (Phase 3). The signals providing the current information are applied to the current sensor inputs IIN1, IIP1, IIN2, IIP2 and IIN3, IIP3.

The output frequency of the SA2005F energy metering integrated circuit at rated conditions is 64Hz on FOUT (PGM0=0, PGM1=1).

One pulse (measured in Watt second) correspond to an energy measured of $3 \times I_{RATED} \times V_{RATED} / 64Hz$.

For a more detailed description see the Input Signals section.

INPUT SIGNALS

Analog Input Configuration

The current and voltage sensor inputs are illustrated in figure 3. These inputs are protected against electrostatic discharge

through clamping diodes, in conjunction with the amplifiers input configuration. The feedback loops from the outputs of the amplifiers A_i and A_v generate virtual shorts on the signal inputs. Exact duplications of the input currents are generated for the analog processing circuitry.

Voltage Reference Connection (VREF)

A bias resistor of 24k provides an optimum bias conditions on chip. Calibration of the SA2005F should be done on the voltage inputs of the device as described in Typical Applications.

Current Sense Inputs (IIN1, IIP1, IIN2, IIP2, IIN3, IIP3)

At rated current the resistor values should be selected for input currents of 16µA_{RMS}. Referring to figure 5, the resistors R1 and R2 on current channel 1, resistors R3 and R4 on current channel 2 and resistors R5 and R6 on current channel 3, define the current level into the current sense inputs of the SA2005F. The current sense inputs saturates at an input current of ±25µA peak. Resistors R25, R26 and R27 are the current transformer termination resistors. The voltage drop across the termination resistors should be at least 20mV at rated conditions. Values for the current sense inputs are calculated as follows:

$$R_1 = R_2 = (I_L / 16\mu A_{RMS}) \times R_{25} / 2$$

$$R_3 = R_4 = (I_L / 16\mu A_{RMS}) \times R_{26} / 2$$

$$R_5 = R_6 = (I_L / 16\mu A_{RMS}) \times R_{27} / 2$$

Where:

I_L = Line current/CT-ratio

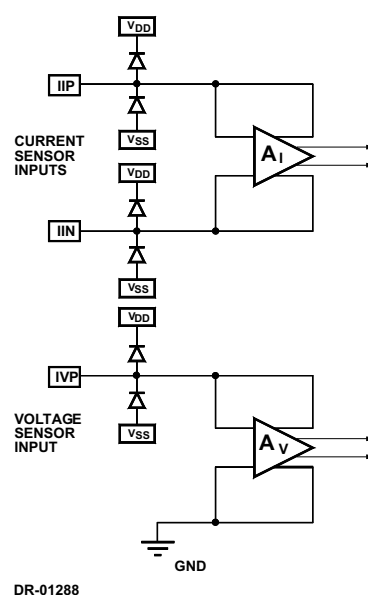

Figure 3: Analog Input Internal Configuration



Voltage Sense Inputs (IVN1, IVN2, IVN3)

The current into the voltage sense inputs (virtual ground) should be set to 14µA_{RMS} at rated voltage conditions. The individual mains voltages are divided down to 14V_{RMS} per phase. The resistors R8, R9 and R10 set the current for the voltage sense inputs. The voltage sense inputs saturate at an input current of ±25µA peak.

Pulse Programming Inputs (PGM0, PGM1)

The pulse programming inputs PGM1 and PGM0 define the representation of energy measured by the device on FOUT. The table below shows the difference between the various modes.

Mode	PGM1	PGM0	Frequency at rated conditions	Forward Pulse Width	Reverse Pulse Width
0	0	0	64Hz	1.14ms	3.4ms
1	0	1	64Hz	1.14ms	1.14ms
2	1	0	64Hz	1.14ms	1.14ms
3	1	1	1160Hz	71µs	71µs

Test Inputs (TCLK, TEST)

The TEST and TCLK inputs are manufacturers test pins and must be connected to VSS in a metering application.

OUTPUT SIGNALS

Direction Indication (DIR)

The SA2005F indicates the measured energy flow direction on pin DIR. A logic 0 on pin DIR indicates reverse energy flow. Reverse energy flow is defined as the condition where the voltage sense input and current sense input are out of phase (greater than 90 degrees). Positive energy flow, when voltage sense and current sense input are in phase, is indicated on pin

DIR as a logic 1. The DIR pin may be used to drive a LED in order to indicate reverse energy flow.

Frequency Output (FOUT)

The sum of the measured power, from the three phases produce a pulse rate of 64Hz or 1160Hz (mode 3), at rated conditions on FOUT. The format of the pulse output signal, which provides power/energy and direction information is shown in figure 4. Refer to Pulse Programming Inputs for pulse widths.

The following equation may be used for calculating the output frequency:

$$f = 11.16 \times FOUTX \times ((I_{I1} \times I_{V1}) + (I_{I2} \times I_{V2}) + (I_{I3} \times I_{V3})) / 3 \times I_R$$

Where:

FOUTX = Nominal rated frequency (64Hz/1160Hz)

I_{I1}, I_{I2}, I_{I3} = Input currents for current sensor inputs (16µA at rated line current)

I_{V1}, I_{V2}, I_{V3} = Input currents for voltage sensor inputs (14µA at rated line voltage)

I_R = Reference current (typically 50µA)

An integrated anti-creep function ensures that no pulses are generated at zero line currents.

ELECTROSTATIC DISCHARGE (ESD) PROTECTION

The SA2005F integrated circuit's inputs/outputs are protected against ESD.

POWER CONSUMPTION

The overall power consumption rating of the SA2005F integrated circuit is less than 50 mW with a 5V supply.

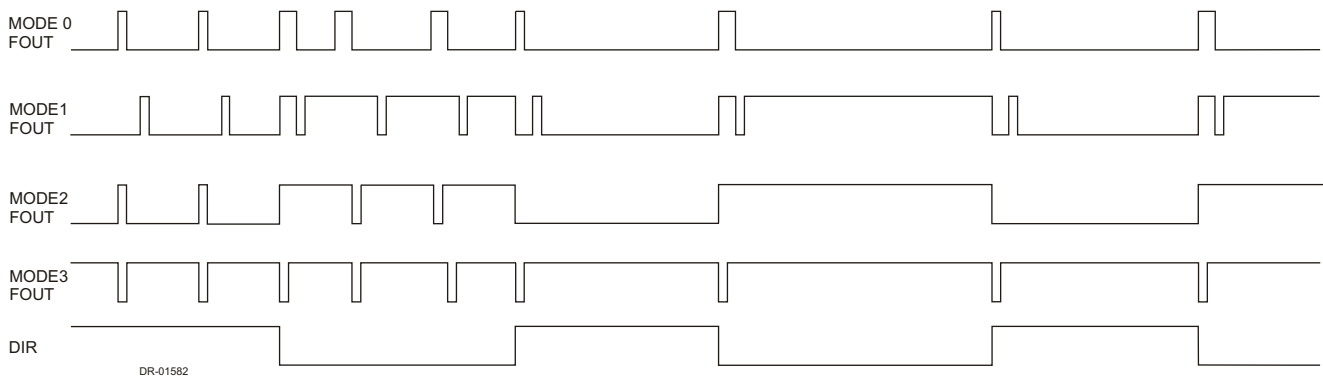

Note: Frequency of pulse rate in MODE 3 is 18 times higher than other modes

Figure 4: FOUT options



TYPICAL APPLICATION

In figure 5, the components required for the three phase power/energy metering section of a meter, is shown. The application uses current transformers for current sensing. The 4-wire meter section is capable of measuring 3x230V/80A with precision better than Class 1.

The most important external components for the SA2005F integrated circuit are the current sense resistors, the voltage sense resistors as well as the bias setting resistor.

BIAS RESISTOR

R7 defines all on-chip and reference currents. With R7=24k , optimum conditions are set. Device calibration is done on the voltage inputs of the device.

CT TERMINATION RESISTOR

The voltage drop across the CT termination resistor at rated current should be at least 20mV. The CT's used have low phase shift and a ratio of 1:2500. The CT is terminated with a 2.7 resistor giving a voltage drop across the termination resistor 864mV at rated conditions (Imax for the meter).

CURRENT SENSE RESISTORS

The resistors R1 and R2 define the current level into the current sense inputs of phase one of the device. The resistor values are selected for an input current of 16µA on the current inputs at rated conditions.

According to equation described in the Current Sense inputs section:

$$\begin{aligned}
 R1 = R2 &= (I_L / 16\mu A) \times R_{sh} / 2 \\
 &= 80A / 2500 / 16\mu A \times 2.7 / 2 \\
 &= 2.7k
 \end{aligned}$$

I_L = Line current / CT Ratio

The three current channels are identical so R1 = R2 = R3 = R4 = R5 = R6.

VOLTAGE DIVIDER

The voltage divider is calculated for a voltage drop of 14V. Equations for the voltage divider in figure 5 are:

$$RA = R16 + R19 + R22$$

$$RB = R8 \parallel (R13 + P1)$$

Combining the two equations gives:

$$(RA + RB) / 230V = RB / 14V$$

A 5k trimpot is used in each of voltage channel for meter calibration. The center position of the pot is used in the calculations. P1 = 2.5k and values for resistors R13 = 22k and R8 = 1M is chosen.

Substituting the values result in:

$$RB = 23.9k$$

$$RA = RB \times (230V / 14V - 1)$$

$$RA = 368.9k.$$

Resistor values of R16, R19 and R22 is chosen to be 120k, 120k and 130k.

The three voltage channels are identical so R14= R15= R16 = R17 = R18 = R19 and R20 = R21= R22.

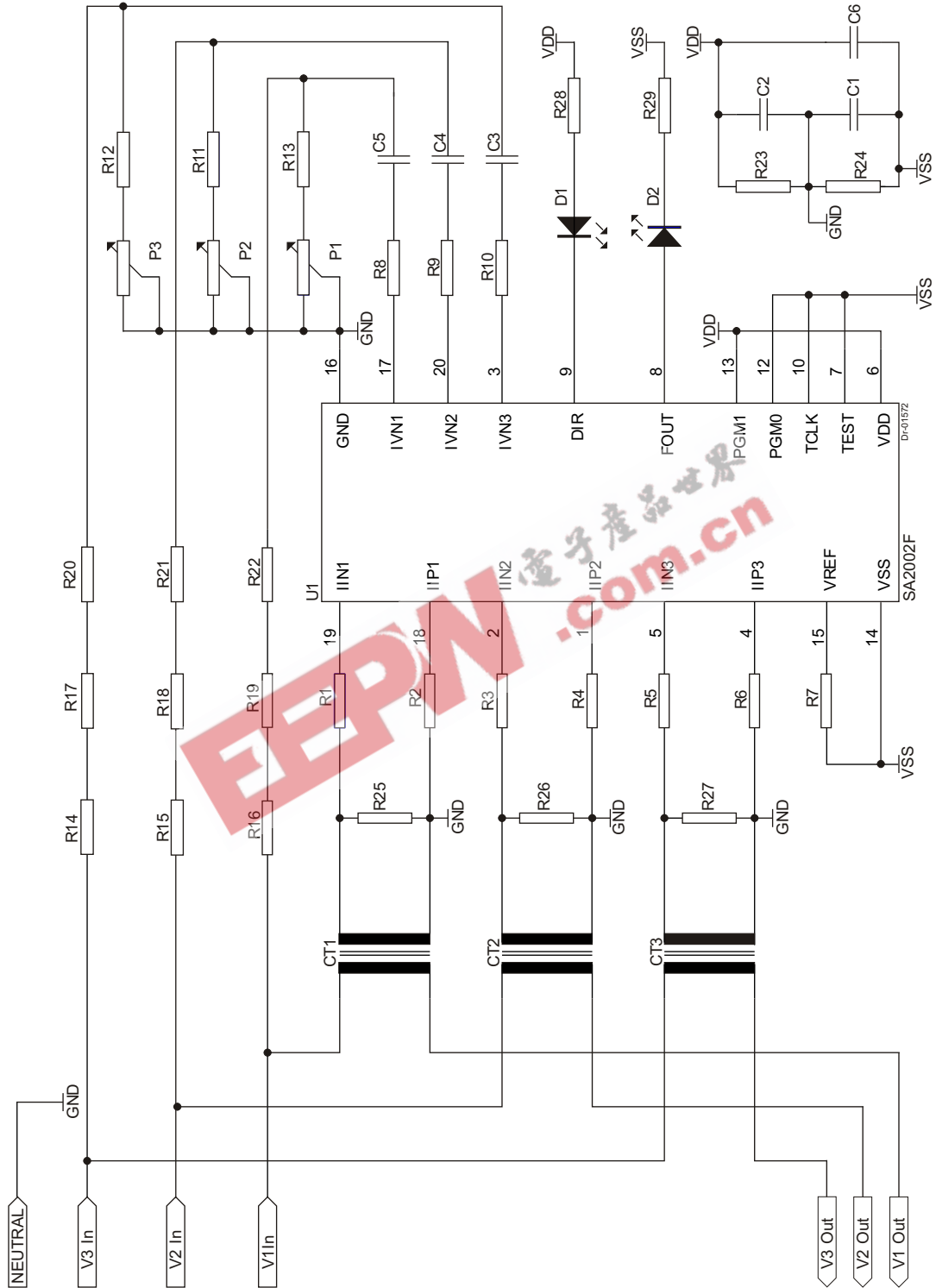

Figure 5: Application Circuit



Parts List for Application Circuit: Figure 5

Symbol	Description	Detail
U1	SA2005F	DIP-20/SOIC-20
R1	Resistor, 2.7k, 1/4W, 1% metal	Note 1
R2	Resistor, 2.7k, 1/4W, 1% metal	Note 1
R3	Resistor, 2.7k, 1/4W, 1% metal	Note 1
R4	Resistor, 2.7k, 1/4W, 1% metal	Note 1
R5	Resistor, 2.7k, 1/4W, 1% metal	Note 1
R6	Resistor, 2.7k, 1/4W, 1% metal	Note 1
R7	Resistor, 24k, 1/4W, 1%, metal	
R8	Resistor, 1M, 1/4W, 1%, metal	
R9	Resistor, 1M, 1/4W, 1%, metal	
R10	Resistor, 1M, 1/4W, 1%, metal	
R11	Resistor, 22k, 1/4W, 1%, metal	
R12	Resistor, 22k, 1/4W, 1%, metal	
R13	Resistor, 22k, 1/4W, 1%, metal	
R14	Resistor, 120k, 1/4W, 1%, metal	
R15	Resistor, 120k, 1/4W, 1%, metal	
R16	Resistor, 120k, 1/4W, 1%, metal	
R17	Resistor, 120k, 1/4W, 1%, metal	
R18	Resistor, 120k, 1/4W, 1%, metal	
R19	Resistor, 120k, 1/4W, 1%, metal	
R20	Resistor, 130k, 1/4W, 1%, metal	
R21	Resistor, 130k, 1/4W, 1%, metal	
R22	Resistor, 130k, 1/4W, 1%, metal	
R23	Resistor, 1k, 1/4W, 1%, metal	
R24	Resistor, 1k, 1/4W, 1%, metal	
R25	Resistor, 2.7R, 1/4W, 1%, metal	Note 1
R26	Resistor, 2.7R, 1/4W, 1%, metal	Note 1
R27	Resistor, 2.7R, 1/4W, 1%, metal	Note 1
P1	Trim pot, 5k, Multi turn	
P2	Trim pot, 5k, Multi turn	
P2	Trim pot, 5k, Multi turn	Note 1
C1	Capacitor, 220nF	
C2	Capacitor, 220nF	
C3	Capacitor, 820nF	Note 2
C4	Capacitor, 820nF	Note 2
C5	Capacitor, 820nF	Note 2
C6	Capacitor, 820nF	Note 3
LED1	3mm Light emitting diode	
LED2	3mm Light emitting diode	
CT1	Current Transformer, TZ76	
CT2	Current Transformer, TZ76	
CT3	Current Transformer, TZ76	

Note 1: Resistor (R1 to R6) values are dependant on the selection of the termination resistors (R25 to R27) and CT combination.

Note 2: Capacitor values may be selected to compensate for phase errors caused by the current transformers.

Note 3: Capacitor C6 to be positioned as close as possible to supply pins V_{DD} and V_{SS} of U1 as possible.



sames

SA2005F

NOTES:

EEPW 电子产品世界
.com.cn

**DISCLAIMER:**

The information contained in this document is confidential and proprietary to South African Micro-Electronic Systems (Pty) Ltd ("SAMES") and may not be copied or disclosed to a third party, in whole or in part, without the express written consent of SAMES. The information contained herein is current as of the date of publication; however, delivery of this document shall not under any circumstances create any implication that the information contained herein is correct as of any time subsequent to such date. SAMES does not undertake to inform any recipient of this document of any changes in the information contained herein, and SAMES expressly reserves the right to make changes in such information, without notification, even if such changes would render information contained herein inaccurate or incomplete. SAMES makes no representation or warranty that any circuit designed by reference to the information contained herein, will function without errors and as intended by the designer.

Any sales or technical questions may be posted to our e-mail address below:

energy@sames.co.za

For the latest updates on datasheets, please visit our web site:

<http://www.sames.co.za>

**SOUTH AFRICAN MICRO-ELECTRONIC SYSTEMS
DIVISION OF LABAT TECHNOLOGIES (PTY) LTD**

Tel: (012) 333-6021

Tel: Int +27 12 333-6021

Fax: (012) 333-8071

Fax: Int +27 12 333-8071

**P O BOX 15888
33 ELAND STREET
LYNN EAST 0039
REPUBLIC OF SOUTH AFRICA**

**33 ELAND STREET
KOEDOESPOORT INDUSTRIAL AREA
PRETORIA
REPUBLIC OF SOUTH AFRICA**