



# DATA SHEET

## SB120S~SB1100S

### SCHOTTKY BARRIER RECTIFIERS

**VOLTAGE** 20 to 100 Volts **CURRENT** 1.0 Amperes

A-405

Unit: inch(mm)

#### FEATURES

- Plastic package has Underwriters Laboratory Flammability Classification 94V-O utilizing Flame Retardant Epoxy Molding Compound.
- Exceeds environmental standards of MIL-S-19500/228
- For use in low voltage,high frequency inverters ,free wheeling , and polarity protection applications .
- Both normal and Pb free product are available :  
Normal : 80~95% Sn, 5~20% Pb  
Pb free: 98.5% Sn above

#### MECHANICAL DATA

Case: A-405 Molded plastic  
Terminals: Axial leads, solderable per MIL-STD-202,Method 208  
Polarity: Color band denotes cathode  
Mounting Position: Any  
Weight: 0.008 ounces, 0.22grams

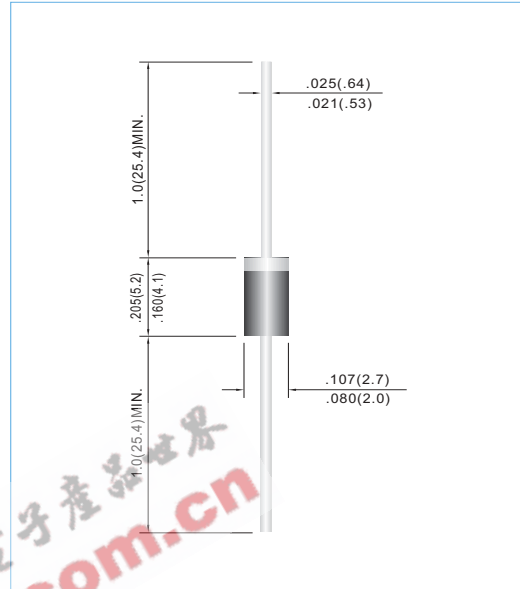

### MAXIMUM RATINGS AND ELECTRICAL CHARACTERISTICS

Ratings at 25°C ambient temperature unless otherwise specified. Single phase, half wave, 60 Hz, resistive or inductive load.

PARAMETER	SYMBOL	SB120S	SB130S	SB140S	SB150S	SB160S	SB180S	SB1100S	UNITS
Maximum Recurrent Peak Reverse Voltage	V <sub>RRM</sub>	20	30	40	50	60	80	100	V
Maximum RMS Voltage	V <sub>RMS</sub>	14	21	28	35	42	56	70	V
Maximum DC Blocking Voltage	V <sub>DC</sub>	20	30	40	50	60	80	100	V
Maximum Average Forward Rectified Current .375"(9.5mm) lead length at T <sub>A</sub> =75°C	I <sub>AV</sub>	1.0							A
Peak Forward Surge Current : 8.3ms single half sine-wave superimposed on rated load(JEDEC method)	I <sub>FSM</sub>	30							A
Maximum Forward Voltage at 1.0A	V <sub>F</sub>	0.50			0.70		0.85		V
Maximum DC Reverse Current T <sub>A</sub> =25°C at Rated DC Blocking Voltage T <sub>A</sub> =100°C	I <sub>R</sub>					0.5 10			mA
Maximum Thermal Resistance	R <sub>θJA</sub>	50							°C / W
Operating Junction and Storage Temperature Rang	T <sub>J</sub> ,T <sub>STG</sub>	-50 TO +125							°C



**RATING AND CHARACTERISTIC CURVES**

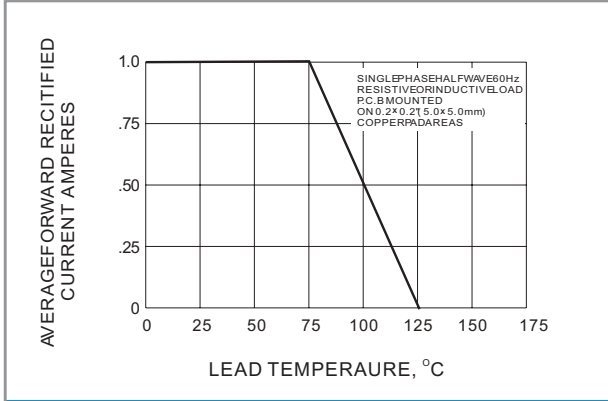

**Fig.1- FORWARD CURRENT DERATING CURVE**

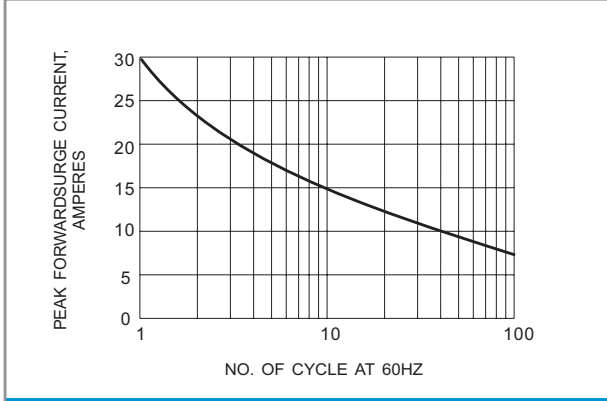

**Fig.2- MAXIMUM NON-REPETITIVE PEAK FORWARD SURGE CURRENT**

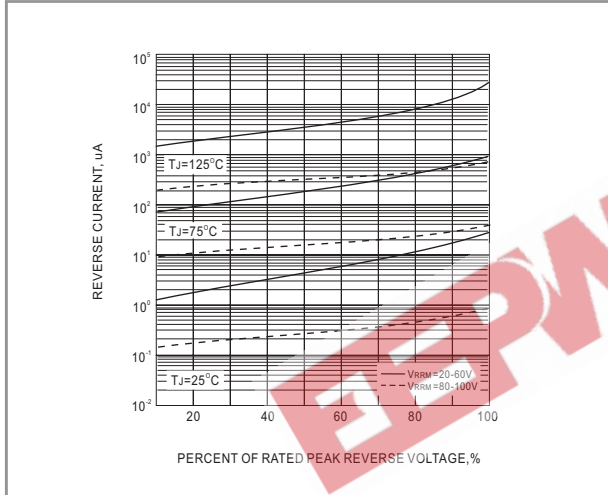

**Fig.3- TYPICAL REVERSE CHARACTERISTIC**

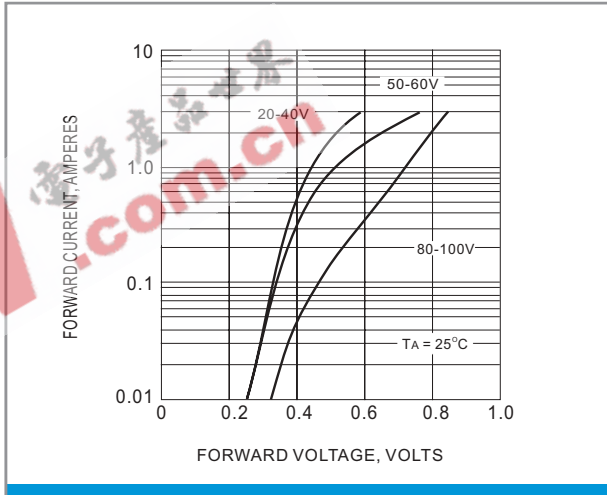

**Fig.4- TYPICAL INSTANTANEOUS FORWARD CHARACTERISTIC**