

Features

- Low Forward Voltage Drop
- Guard Ring Construction for Transient Protection
- Negligible Reverse Recovery Time

Mechanical Data

- Case: SOD-123, Plastic
- Case material - UL Flammability Rating Classification 94V-0
- Moisture sensitivity: Level 1 per J-STD-020A
- Polarity: Cathode Band
- Leads: Solderable per MIL-STD-202, Method 208
- Marking: Date Code and Type Code, See Page 2
- Type Codes: SD103AW S4
SD103BW S5 or S4
SD103CW S6 or S5 or S4
- Weight: 0.01 grams (approx.)
- Ordering Information: See Page 2

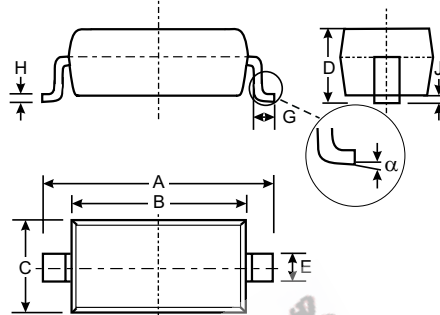

SOD-123		
Dim	Min	Max
A	3.55	3.85
B	2.55	2.85
C	1.40	1.70
D	—	1.35
E	0.55 Typical	
G	0.25	—
H	0.11 Typical	
J	—	0.10
α	0°	8°
All Dimensions in mm		

Maximum Ratings @ T_A = 25°C unless otherwise specified

Characteristic	Symbol	SD103AW	SD103BW	SD103CW	Unit
Peak Repetitive Reverse Voltage	V _{RRM}			20	V
Working Peak Reverse Voltage	V _{RWM}	40	30		
DC Blocking Voltage	V _R			20	V
RMS Reverse Voltage	V _{R(RMS)}	28	21	14	V
Forward Continuous Current (Note 1)	I _{FM}		350		mA
Non-Repetitive Peak Forward Surge Current @ t ≤ 1.0s	I _{FSM}		1.5		A
Power Dissipation (Note 1)	P _d		400		mW
Thermal Resistance, Junction to Ambient Air (Note 1)	R _{θJA}		300		°C/W
Operating and Storage Temperature Range	T _j , T _{STG}		-65 to +125		°C

Electrical Characteristics @ T_A = 25°C unless otherwise specified

Characteristic	Symbol	Min	Typ	Max	Unit	Test Condition
Reverse Breakdown Voltage (Note 2)	V _{(BR)R}	40 30 20	—	—	V	I _R = 100μA
Forward Voltage Drop (Note 2)	V _{FM}	—	—	0.37 0.60	V	I _F = 20mA I _F = 200mA
Peak Reverse Current (Note 2)	I _{RM}	—	—	5.0	μA	V _R = 30V V _R = 20V V _R = 10V
Total Capacitance	C _T	—	50	—	pF	V _R = 0V, f = 1.0MHz
Reverse Recovery Time	t _{rr}	—	10	—	ns	I _F = I _R = 200mA, I _{rr} = 0.1 x I _R , R _L = 100Ω

- Notes:
1. Part mounted on FR-4 board with recommended pad layout, which can be found on our website at <http://www.diodes.com/datasheets/ap02001.pdf>.
 2. Short duration test pulse used to minimize self-heating effect.

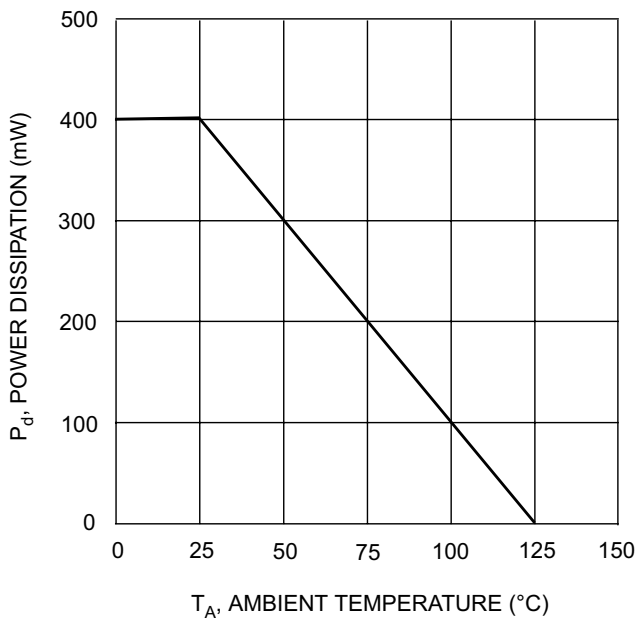

T_A , AMBIENT TEMPERATURE (°C)
Fig. 1 Power Derating Curve

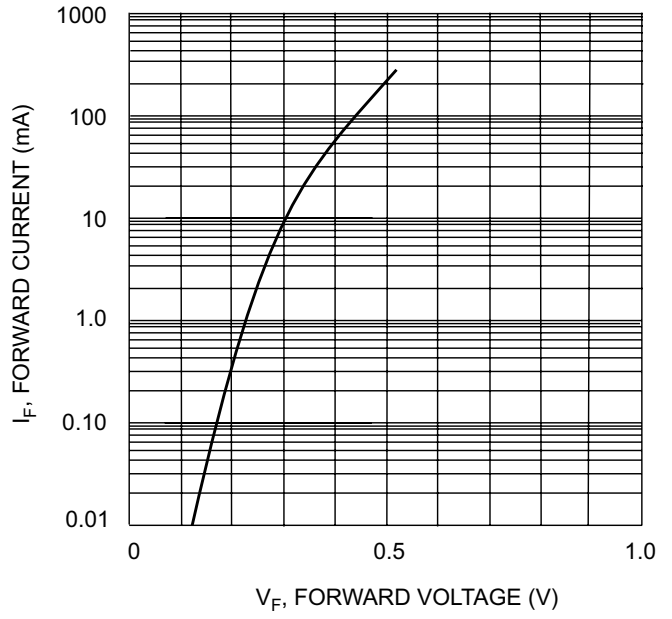

V_F , FORWARD VOLTAGE (V)
Fig. 2 Typical Forward Characteristics

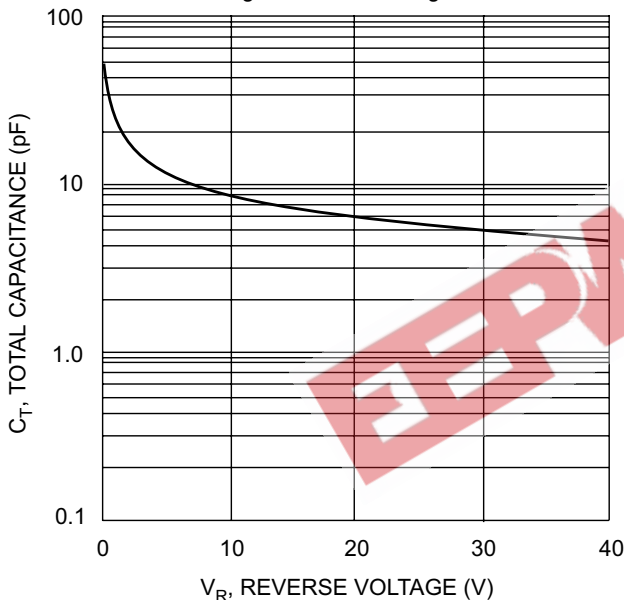

V_R , REVERSE VOLTAGE (V)
Fig. 3 Typ. Total Capacitance vs Reverse Voltage

Ordering Information (Note 3)

Device	Packaging	Shipping
SD103AW-7	SOD-123	3000/Tape and Reel
SD103BW-7	SOD-123	3000/Tape and Reel
SD103CW-7	SOD-123	3000/Tape and Reel

Note: 3. For Packaging Details, go to our website at <http://www.diodes.com/datasheets/ap02007.pdf>.

Marking Information

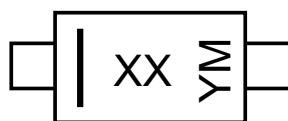

XX = Product Type Marking Code
YM = Date Code Marking
Y = Year (ex: N = 2002)
M = Month (ex: 9 = September)

Date Code Key

Year	1998	1999	2000	2001	2002	2003	2004	2005
Code	J	K	L	M	N	P	R	S

Month	Jan	Feb	March	Apr	May	Jun	Jul	Aug	Sep	Oct	Nov	Dec
Code	1	2	3	4	5	6	7	8	9	O	N	D