

Features

- Low Forward Voltage Drop
- Guard Ring Construction for Transient Protection
- Negligible Reverse Recovery Time
- Low Reverse Capacitance
- Ultra-Small Surface Mount Package

Mechanical Data

- Case: SOD-323, Plastic
- Case material - UL Flammability Rating Classification 94V-0
- Moisture sensitivity: Level 1 per J-STD-020A
- Polarity: Cathode Band
- Leads: Solderable per MIL-STD-202, Method 208
- SD103AWS Marking: S4
- SD103BWS Marking: S5 or S4
- SD103CWS Marking: S6 or S5 or S4
- Weight: 0.004 grams (approx.)

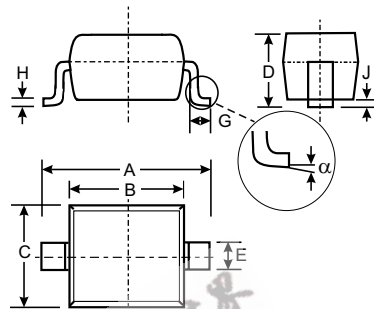

SOD-323		
Dim	Min	Max
A	2.30	2.70
B	1.60	1.80
C	1.20	1.40
D	1.05 Typical	
E	0.25	0.35
G	0.20	0.40
H	0.10	0.15
J	0.05 Typical	
α	0°	8°
All Dimensions in mm		

Maximum Ratings @ $T_A = 25^\circ\text{C}$ unless otherwise specified

Characteristic	Symbol	SD103AWS	SD103BWS	SD103CWS	Unit
Peak Repetitive Reverse Voltage	V_{RRM}				
Working Peak Reverse Voltage	V_{RWM}	40	30	20	V
DC Blocking Voltage	V_R				
RMS Reverse Voltage	$V_{R(RMS)}$	28	21	14	V
Forward Continuous Current (Note 1)	I_{FM}	350			mA
Non-Repetitive Peak Forward Surge Current @ $t \leq 1.0\text{s}$	I_{FSM}	1.5			A
Power Dissipation (Note 1)	P_d	200			mW
Thermal Resistance, Junction to Ambient Air (Note 1)	$R_{\theta JA}$	625			$^\circ\text{C/W}$
Operating and Storage Temperature Range	T_j, T_{STG}	-65 to +125			$^\circ\text{C}$

Electrical Characteristics @ $T_A = 25^\circ\text{C}$ unless otherwise specified

Characteristic	Symbol	Min	Typ	Max	Unit	Test Condition
Reverse Breakdown Voltage (Note 2)	$V_{(BR)R}$	40 30 20	—	—	V	$I_R = 10\mu\text{A}$ $I_R = 10\mu\text{A}$ $I_R = 10\mu\text{A}$
Forward Voltage Drop (Note 2)	V_{FM}	—	—	0.37 0.60	V	$I_F = 20\text{mA}$ $I_F = 200\text{mA}$
Peak Reverse Current (Note 2)	I_{RM}	—	—	5.0	μA	$V_R = 30\text{V}$ $V_R = 20\text{V}$ $V_R = 10\text{V}$
Total Capacitance	C_T	—	50	—	pF	$V_R = 0\text{V}, f = 1.0\text{MHz}$
Reverse Recovery Time	t_{rr}	—	10	—	ns	$I_F = I_R = 200\text{mA}$, $I_{rr} = 0.1 \times I_R, R_L = 100\Omega$

- Notes:
1. Part mounted on FR-4 PC board with recommended pad layout, which can be found on our website at <http://www.diodes.com/datasheets/ap02001.pdf>.
 2. Short duration test pulse used to minimize self-heating effect.

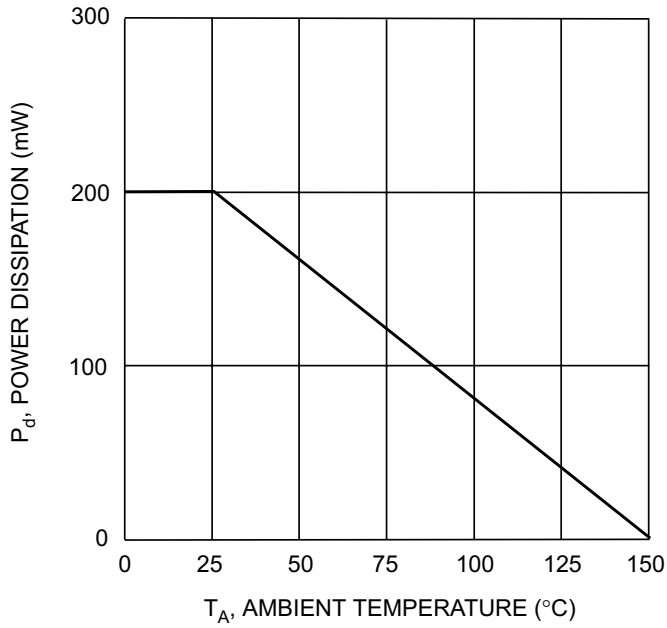

Fig. 1 Power Derating Curve

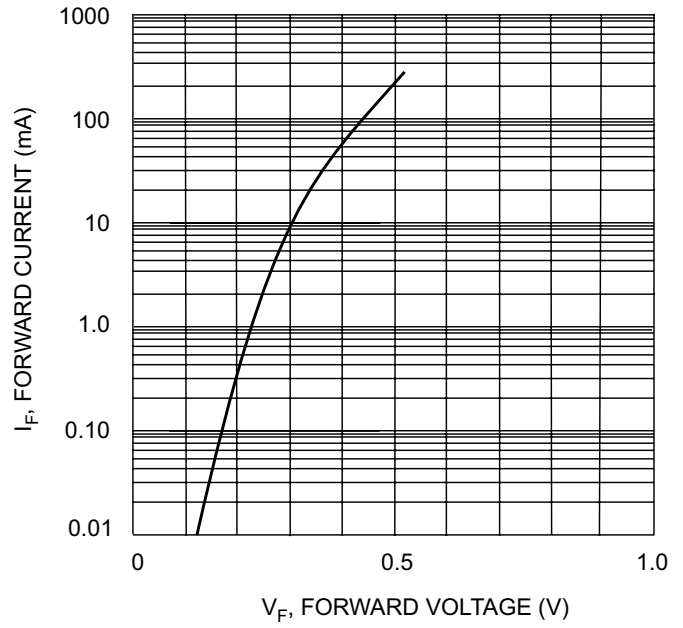

Fig. 2 Typical Forward Characteristics

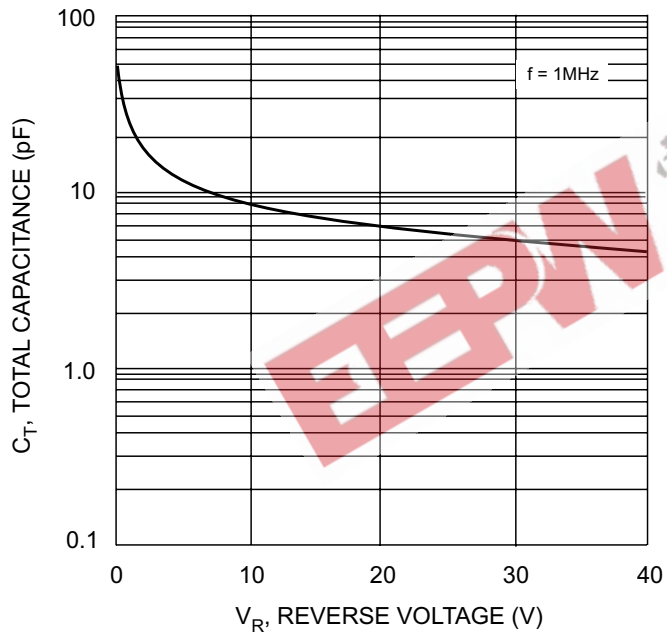

Fig. 3 Total Capacitance vs Reverse Voltage

Ordering Information (Note 3)

Device	Packaging	Shipping
SD103AWS-7	SOD-323	3000/Tape & Reel
SD103BWS-7	SOD-323	3000/Tape & Reel
SD103CWS-7	SOD-323	3000/Tape & Reel

Notes: 3. For Packaging Details, go to our website at: <http://www.diodes.com/datasheets/ap02007.pdf>.

Marking Information

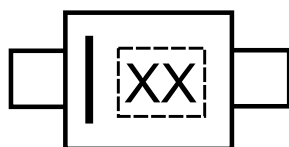

XX = Product Type Marking Code
(See Page 1)