

PROTECTION PRODUCTS

Description

The SDxxC TVS diodes are designed to replace multi-layer varistors (MLVs) in portable applications such as cell phones, notebook computers, and PDA's. They offer superior electrical characteristics such as lower clamping voltage and no device degradation when compared to MLVs. The SDxxC series TVS diodes are designed to protect sensitive semiconductor components from damage or upset due to electrostatic discharge (ESD) and other voltage induced transient events.

The SDxxC is in a SOD-323 package and will protect one bidirectional line. They are available with working voltages of 5 - 24 volts. These devices will fit on the same PCB pad area as an 0805 MLV device. They give the designer the flexibility to protect one line in applications where arrays are not practical. Additionally, it may be "sprinkled" around the board in applications where board space is at a premium.

They may may be used to meet the ESD immunity requirements of IEC 61000-4-2, Level 4 (15kV air, 8kV contact discharge).

Features

- ◆ 350 Watts peak pulse power ($t_p = 8/20\mu s$)
- ◆ Transient protection for data lines to
IEC 61000-4-2 (ESD) 15kV (air), 8kV (contact)
IEC 61000-4-4 (EFT) 40A (5/50ns)
IEC 61000-4-5 (Lightning) 24A (8/20 μs)
- ◆ Small package for use in portable electronics
- ◆ Suitable replacement for MLV's in ESD protection applications
- ◆ Protects one I/O or power line
- ◆ Low clamping voltage
- ◆ Working voltages: 5V, 12V, 15V, 24V
- ◆ Low leakage current
- ◆ Solid-state silicon avalanche technology

Mechanical Characteristics

- ◆ EIAJ SOD-323 package
- ◆ Molding compound flammability rating: UL 94V-0
- ◆ Marking : Marking code
- ◆ Packaging : Tape and Reel per EIA 481

Applications

- ◆ Cell Phone Handsets and Accessories
- ◆ Microprocessor based equipment
- ◆ Personal Digital Assistants (PDA's)
- ◆ Notebooks, Desktops, & Servers
- ◆ Portable Instrumentation
- ◆ Pagers
- ◆ Peripherals

Schematic & PIN Configuration

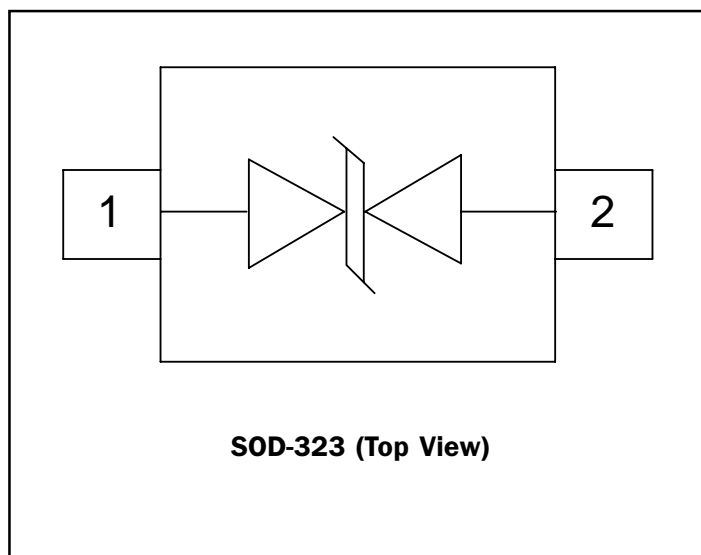

PROTECTION PRODUCTS

Absolute Maximum Rating

Rating	Symbol	Value	Units
Peak Pulse Power (tp = 8/20μs)	P_{pk}	350	Watts
Peak Pulse Current (tp = 8/20μs)	I_{pp}	24	A
ESD Voltage (HBM Waveform per IEC 61000-4-2)	V_{pp}	30	kV
Lead Soldering Temperature	T_L	260 (10 sec.)	°C
Operating Temperature	T_J	-55 to +125	°C
Storage Temperature	T_{STG}	-55 to +150	°C

Electrical Characteristics

SD05C TVS for 5V Lines

Parameter	Symbol	Conditions	Minimum	Typical	Maximum	Units
Reverse Stand-Off Voltage	V_{RWM}				5	V
Reverse Breakdown Voltage	V_{BR}	$I_t = 1mA$	6			V
Reverse Leakage Current	I_R	$V_{RWM} = 5V, T=25^\circ C$			10	μA
Clamping Voltage	V_C	$I_{pp} = 5A, tp = 8/20\mu s$			9.8	V
Clamping Voltage	V_C	$I_{pp} = 24A, tp = 8/20\mu s$			14.5	V
Junction Capacitance	C_j	$V_R = 0V, f = 1MHz$			200	pF

SD12C TVS for 12V Lines

Parameter	Symbol	Conditions	Minimum	Typical	Maximum	Units
Reverse Stand-Off Voltage	V_{RWM}				12	V
Reverse Breakdown Voltage	V_{BR}	$I_t = 1mA$	13.3			V
Reverse Leakage Current	I_R	$V_{RWM} = 12V, T=25^\circ C$			1	μA
Clamping Voltage	V_C	$I_{pp} = 5A, tp = 8/20\mu s$			19	V
Clamping Voltage	V_C	$I_{pp} = 15A, tp = 8/20\mu s$			24	V
Junction Capacitance	C_j	$V_R = 0V, f = 1MHz$			100	pF

PROTECTION PRODUCTS
Electrical Characteristics (Continued)

SD15C TVS for 15V Lines						
Parameter	Symbol	Conditions	Minimum	Typical	Maximum	Units
Reverse Stand-Off Voltage	V_{RWM}				15	V
Reverse Breakdown Voltage	V_{BR}	$I_t = 1mA$	16.7			V
Reverse Leakage Current	I_R	$V_{RWM} = 15V, T=25^\circ C$			1	μA
Clamping Voltage	V_C	$I_{PP} = 5A, tp = 8/20\mu s$			24	V
Clamping Voltage	V_C	$I_{PP} = 12A, tp = 8/20\mu s$			29	V
Junction Capacitance	C_j	$V_R = 0V, f = 1MHz$			75	pF

SD24C TVS for 24V Lines						
Parameter	Symbol	Conditions	Minimum	Typical	Maximum	Units
Reverse Stand-Off Voltage	V_{RWM}				24	V
Reverse Breakdown Voltage	V_{BR}	$I_t = 1mA$	26.7			V
Reverse Leakage Current	I_R	$V_{RWM} = 24V, T=25^\circ C$			1	μA
Clamping Voltage	V_C	$I_{PP} = 5A, tp = 8/20\mu s$			40	V
Clamping Voltage	V_C	$I_{PP} = 8A, tp = 8/20\mu s$			44	V
Junction Capacitance	C_j	$V_R = 0V, f = 1MHz$			50	pF

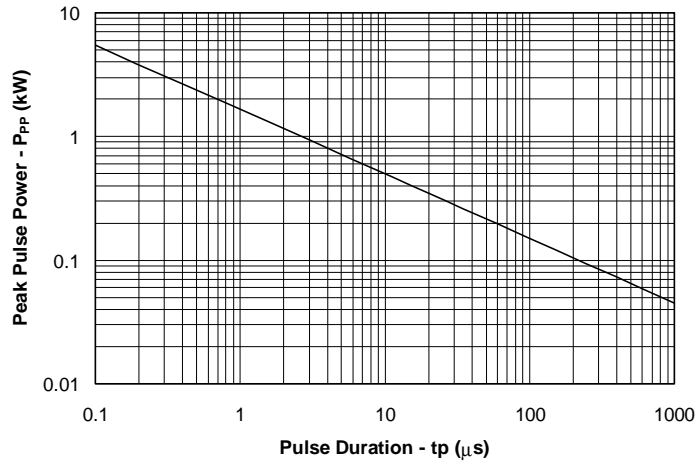
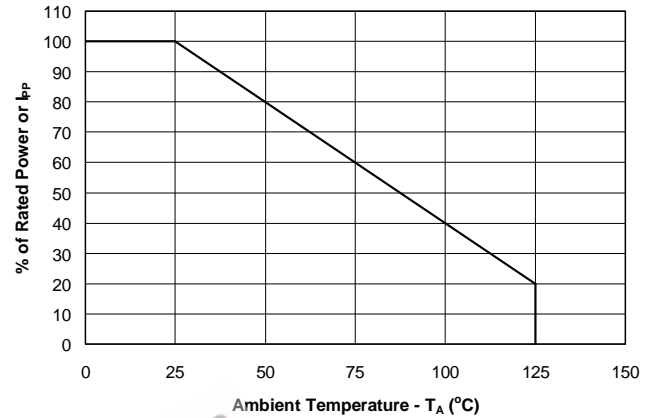
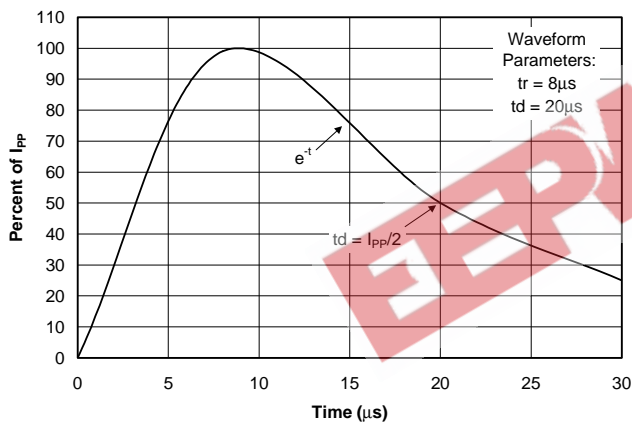
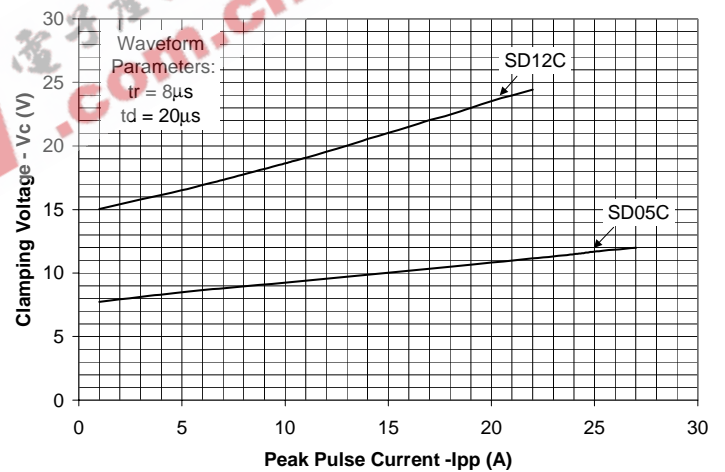
PROTECTION PRODUCTS
Typical Characteristics
Non-Repetitive Peak Pulse Power vs. Pulse Time

Power Derating Curve

Pulse Waveform

Clamping Voltage vs. Peak Pulse Current

PROTECTION PRODUCTS
Applications Information
Device Connection Options

The SDxxC TVS diodes are designed to protect one data, I/O, or power supply line. The device is designed to replace multi-layer varistors (MLVs) in portable applications. It is easily implemented on existing 0805 MLV pads and is only slightly larger than 0603 MLV pads. The device is bidirectional and may be used on lines where the signal polarity is above and below ground. The device is symmetrical, so there is no cathode band.

Circuit Board Layout Recommendations for Suppression of ESD.

Good circuit board layout is critical for the suppression of fast rise-time transients such as ESD. The following guidelines are recommended (Refer to application note SI99-01 for more detailed information):

- Place the TVS near the input terminals or connectors to restrict transient coupling.
- Minimize the path length between the TVS and the protected line.
- The ESD transient return path to ground should be kept as short as possible.
- Place a TVS & decoupling capacitor between power and ground of components that may be vulnerable to electrostatic discharges to the ground plane.
- Minimize all conductive loops including power and ground loops.
- Use multilayer boards when possible.
- Minimize interconnecting line lengths
- Never run critical signals near board edges.
- Fill unused portions of the PCB with ground plane.

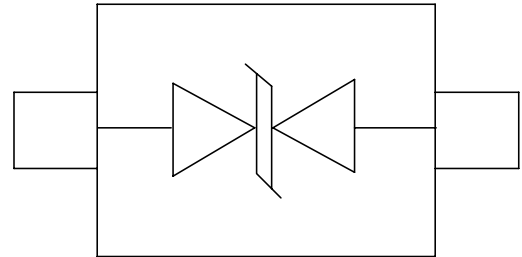
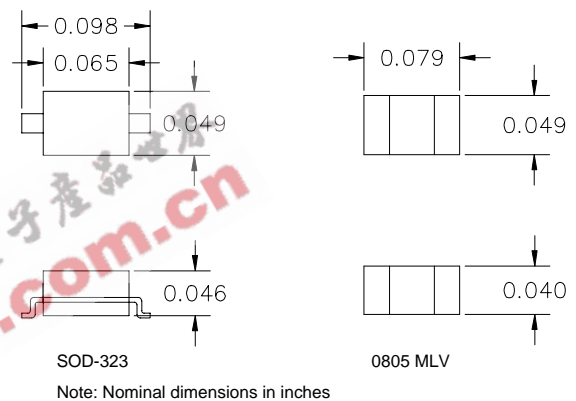
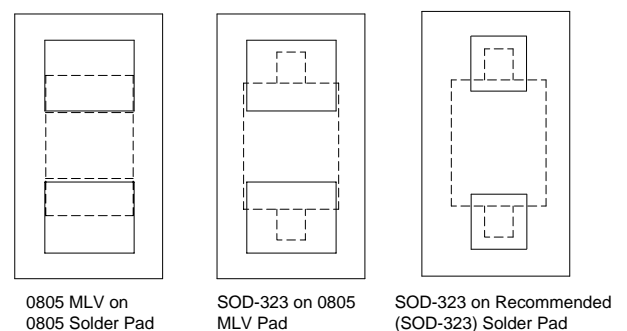
Device Schematic & Pin Configuration

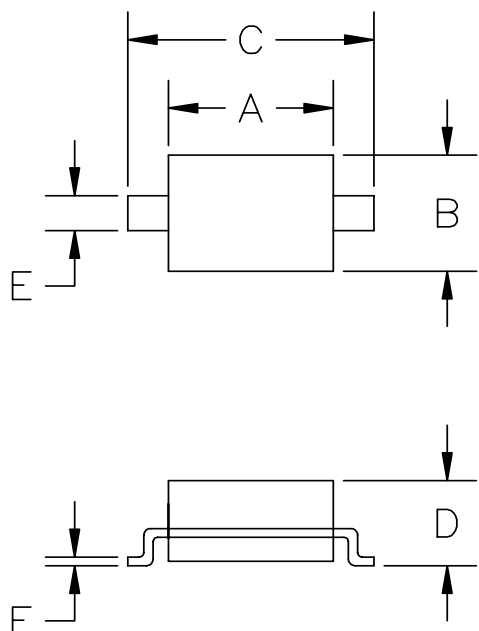
Size Comparison to 0805 MLV

Component Placement Comparison

PROTECTION PRODUCTS
Outline Drawing - SOD-323

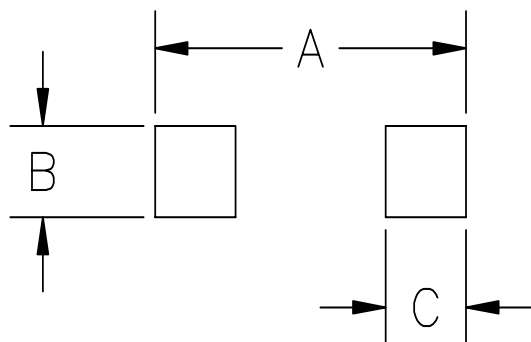
DIM ^N	INCHES		MM ^[1]		NOTE
	MIN	MAX	MIN	MAX	
A	.060	.071	1.5	1.8	—
B	.045	.054	1.2	1.4	—
C	.090	.107	2.3	2.7	—
D	—	.043	—	1.1	—
E	.012	.016	0.3	0.4	—
F	.004	.010	.10	.25	—
H	—	.004	—	.10	—

^[1] CONTROLLING DIMENSION: MILLIMETERS

Land Pattern - SOD-323

DIM ^N	INCHES		MM ^[1]		NOTE
	MIN	MAX	MIN	MAX	
A	—	.120	—	3.05	—
B	—	.031	—	0.8	—
C	—	.031	—	0.8	—

^[1] CONTROLLING DIMENSION: MILLIMETERS

PROTECTION PRODUCTS

Marking Codes

Part Number	Marking Code
SD05C	5/5
SD12C	6/6
SD15C	7/7
SD24C	8/8

Ordering Information

Part Number	Working Voltage	Qty per Reel	Reel Size
SD05C.TC	5V	3,000	7"
SD05C.TG	5V	10,000	13"
SD12C.TC	12V	3,000	7"
SD12C.TG	12V	10,000	13"
SD15C.TC	15V	3,000	7"
SD15C.TG	15V	10,000	13"
SD24C.TC	24V	3,000	7"
SD24C.TG	24V	10,000	13"

電子產品世界
www.semtech.com.cn

Contact Information

Semtech Corporation
 Protection Products Division
 652 Mitchell Rd., Newbury Park, CA 91320
 Phone: (805)498-2111 FAX (805)498-3804