



Micro Commercial Components
21201 Itasca Street Chatsworth
CA 91311
Phone: (818) 701-4933
Fax: (818) 701-4939

SL03 THRU SL24

Features

- SOT-23 Package For surface mount application
- Protects 3.0/3.3 up through 24V Components
- Protects 1 Unidirectional line
- Provides electrically isolated protection
- Tape & Reel EIA Standard 481.

Mechanical Data

- Molded: SOT-23 Surface Mount
- Body marked with device number.
- Mounting Position: Any
- Weight: 0.14 grams (approx.)

MAXIMUM RATINGS

- Operating Temperature: -55°C to +150°C
- Storage Temperature: -55°C to +150°C
- SL03 thru SL24 have a Peak Power: 300 Watts (8/20 usec, Figure 1)
- Pulse Repetition Rate: <.01%

Description

This product provides unidirectional protection for 1 line by connecting the input/output line to pin 1, pin 2 to common or ground and pin 3 (is not connected).

The SL03 thru SL24 product provides board level protection from static electricity and other induced-voltage surges that can damage sensitive circuitry.

These TRANSIENT VOLTAGE SUPPRESSOR (TVS) Diode Arrays protect 3.0/3.3 Volt components such as DRAM's, SRAM's, COMS, HCOMS, HSIC, and low volt. interfaces up to 24 volts. Because of the physical size, weight and protection capabilities, this product is ideal for use in but not limited to miniaturized electronic equipment such as hand held instruments, computers, computer peripherals and cell phones.

Transient Voltage Suppressor 300 Watt

SOT-23

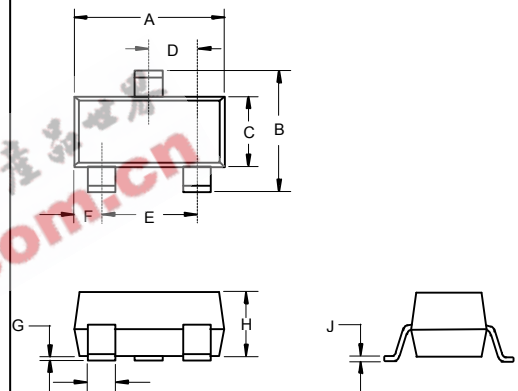

DIM	INCHES		MM		NOTE
	MIN	MAX	MIN	MAX	
A	.110	.120	2.80	3.04	
B	.083	.098	2.10	2.64	
C	.047	.055	1.20	1.40	
D	.035	.041	.89	1.03	
E	.070	.081	1.78	2.05	
F	.018	.024	.45	.60	
G	.0005	.0039	.013	.100	
H	.035	.044	.89	1.12	
J	.003	.007	.085	.180	
K	.015	.020	.37	.51	

Suggested Solder Pad Layout

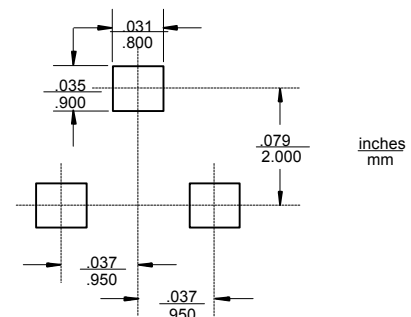

SL03 thru SL24

WAVE FORMS

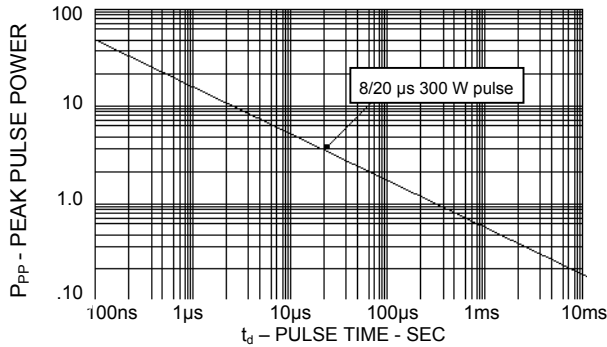

FIGURE 1
Peak Pulse Power Vs Pulse Time

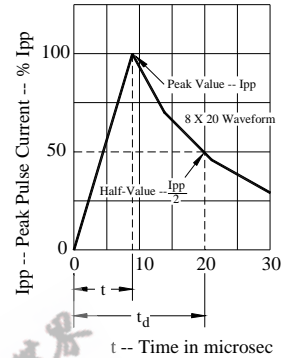
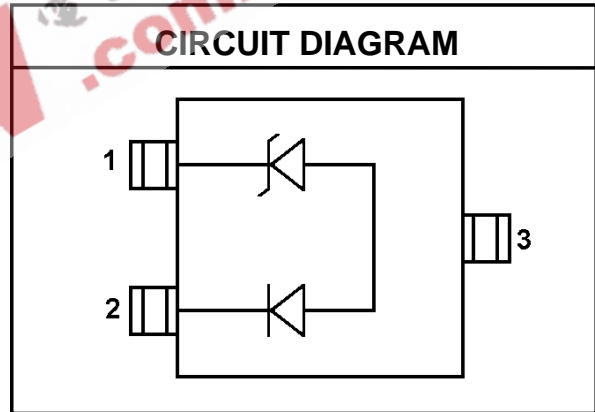
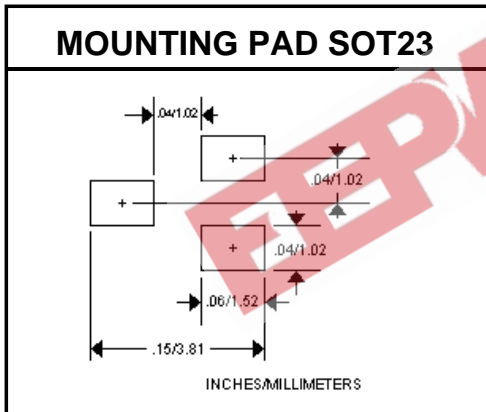

FIGURE 2
Pulse Wave Form



ELECTRICAL CHARACTERISTICS @ 25°C Unless otherwise specified

PART NUMBER	DEVICE MARKING	STAND OFF VOLTAGE V_{WM}	BREAKDOWN VOLTAGE V_{BR} @ 1 mA	CLAMPING VOLTAGE V_C @ 1 Amp (FIGURE 2)	CLAMPING VOLTAGE V_C @ 5 Amp (FIGURE 2)	LEAKAGE CURRENT I_D @ V_{WM}	CAPACITANCE @ 0V, 1 MHz	TEMPERATURE COEFFICIENT OF V_{BR}	
		VOLTS	VOLTS	VOLTS	VOLTS	μA	pF	mV/°C	
			MIN	MAX	MAX	MAX	MAX	MAX	
SL03	L03	3.3		4	8	11	200	3	-5
SL05	L05	5.0		6.0	10.8	13	100	3	3
SL12	L12	12.0		13.3	19	26	1	3	10
SL15	L15	15.0		16.7	25	32	1	3	13
SL24	L24	24.0		26.7	44	57	1	3	30

NOTE: Transient Voltage Suppression (TVS) product is normally selected based on its stand off Voltage V_{WM} . Product selected voltage should be equal to or greater than the continuous peak operating voltage of the circuit to be protected.