



DC COMPONENTS CO., LTD.

RECTIFIER SPECIALISTS

**SM220
THRU
SM260**

TECHNICAL SPECIFICATIONS OF SURFACE MOUNT SCHOTTKY BARRIER RECTIFIER
VOLTAGE RANGE - 20 to 60 Volts **CURRENT - 2.0 Amperes**

FEATURES

- * High current capability
- * Ideal for surface mounted applications
- * Low leakage current for high efficiency

MECHANICAL DATA

- * Case: Molded plastic
- * Epoxy: UL 94V-0 rate flame retardant
- * Terminals: Solder plated solderable per MIL-STD-202E, Method 208 guaranteed
- * Polarity: Color band denotes cathode end
- * Mounting position: Any
- * Weight: 0.12 gram

MAXIMUM RATINGS AND ELECTRICAL CHARACTERISTICS

Ratings at 25 °C ambient temperature unless otherwise specified.
 Single phase, half wave, 60 Hz, resistive or inductive load.
 For capacitive load, derate current by 20%.

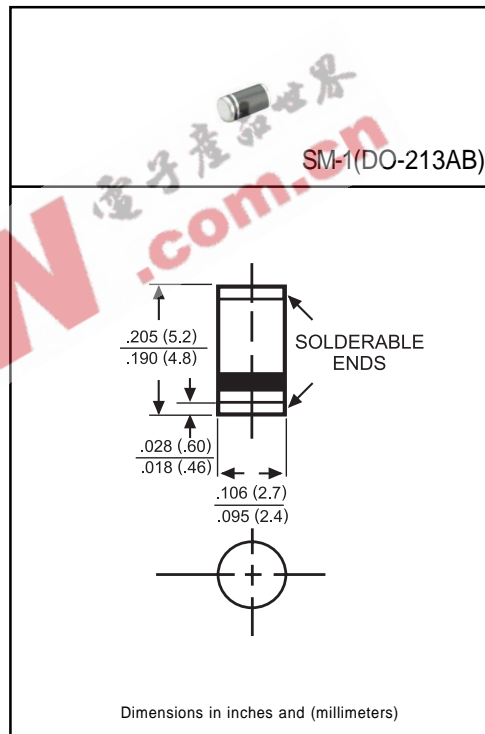

	SYMBOL	SM220	SM230	SM240	SM250	SM260	UNITS
Maximum Recurrent Peak Reverse Voltage	VRRM	20	30	40	50	60	Volts
Maximum RMS Voltage	VRMS	14	21	28	35	42	Volts
Maximum DC Blocking Voltage	VDC	20	30	40	50	60	Volts
Maximum Average Forward Rectified Current at TA=90°C	IO	2.0					Amps
Peak Forward Surge Current 8.3 ms single half sine-wave superimposed on rated load (JEDEC Method)	IFSM	40					Amps
Maximum Instantaneous Forward Voltage at 2.0A DC	VF	.45	.55	.60	.75		
Maximum DC Reverse Current at Rated DC Blocking Voltage	@ TA = 25°C	2.0					mAmps
	@ TA = 100°C	20					
Typical Thermal Resistance (Note1)	RθJA	40					°C/W
Typical Junction Capacitance (Note 2)	CJ	200					pF
Storage Operating Temperature Range	TJ, TSTG	-65 to + 125					°C

NOTES : 1. Thermal Resistance (Junction to Ambient), .24in² (6.0mm²) copper pads to each terminal.
 2. Measured at 1 MHz and applied reverse voltage of 4.0 volts.

RATING AND CHARACTERISTIC CURVES (SM220 THRU SM260)

FIG. 1 - TYPICAL FORWARD CURRENT DERATING CURVE

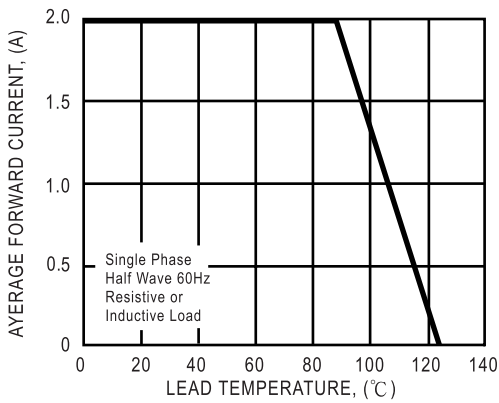

FIG. 2 - TYPICAL INSTANTANEOUS FORWARD CHARACTERISTICS

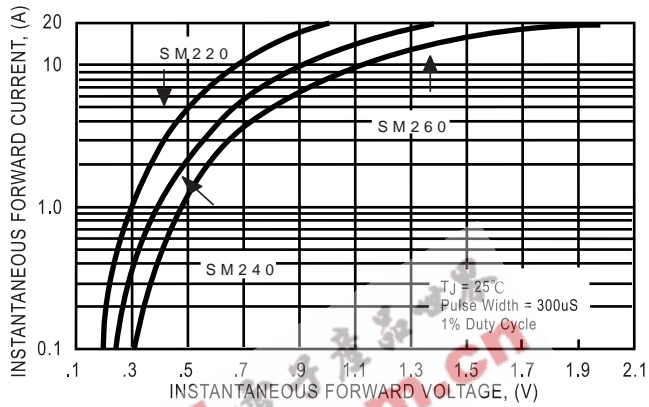

FIG. 3 - TYPICAL REVERSE CHARACTERISTICS

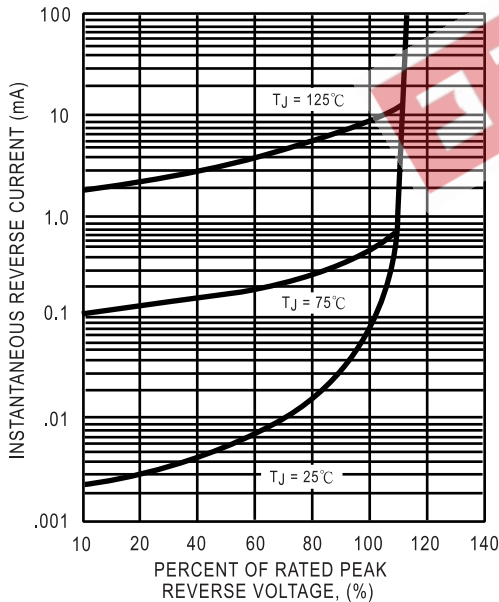

FIG. 4 - MAXIMUM NON-REPETITIVE FORWARD SURGE CURRENT

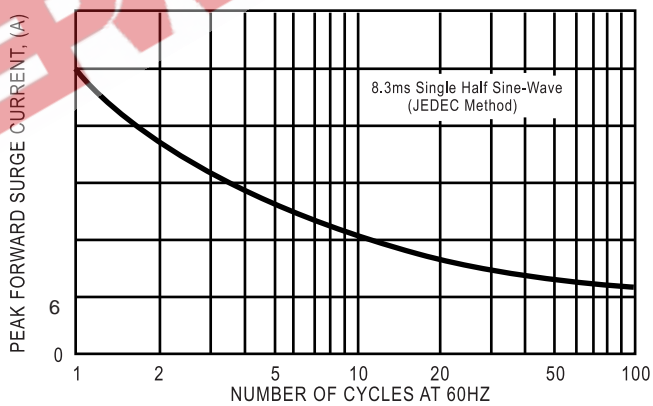

FIG. 5 - TYPICAL JUNCTION CAPACITANCE

