

## OVERVIEW

SM6610 series is high-accuracy temperature sensor IC in the ultra small package. By using CMOS circuit, it realizes low voltage and low current consumption. The power down function contributes to decrease the current consumption of application set by activating intermittent function easily.

## FEATURES

- High linearity:  $\pm 0.5\%$  typ. ( $T_a = -20$  to  $80^\circ\text{C}$ )
- Operating temperature range:  $-40$  to  $100^\circ\text{C}$  ( $V_{DD} \geq 2.7\text{V}$ )
- Maximum output current load:  $\pm 250\mu\text{A}$
- Output reference: VSS
- Low current consumption:  $5.5\mu\text{A}$  typ. ( $T_a = 25^\circ\text{C}$ )
- Low stand-by current:  $0.5\mu\text{A}$  max.
- Very small plastic package: SC82AB
- Very small leadless package: VSP-4
- Power down function
- Molybdenum-gate CMOS Process

## PINOUT

(Top view)

### VSP-4



## ORDERING INFORMATION

Device	Package	Output center current [V] ( $T_a = 25^\circ\text{C}$ )	Temperature coefficient [mV/ $^\circ\text{C}$ ]	Operating voltage [V]	Accuracy [ $^\circ\text{C}$ ]
SM6610AH	SC82AB	1.933	-10.7	4.0 to 6.0	$\pm 5.0$
SM6610AD	VSP-4				
SM6610BH	SC82AB	1.449	-8.2	2.4 to 6.0	$\pm 5.0$
SM6610BD	VSP-4				

**PACKAGE DIMENSIONS**

(Unit : mm)

**VSP-4**

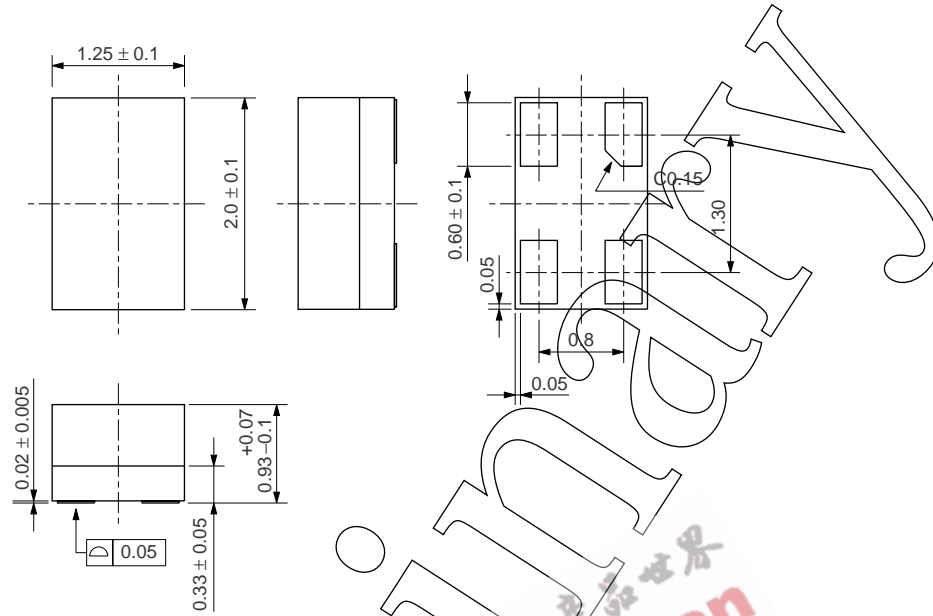

**SC82AB**

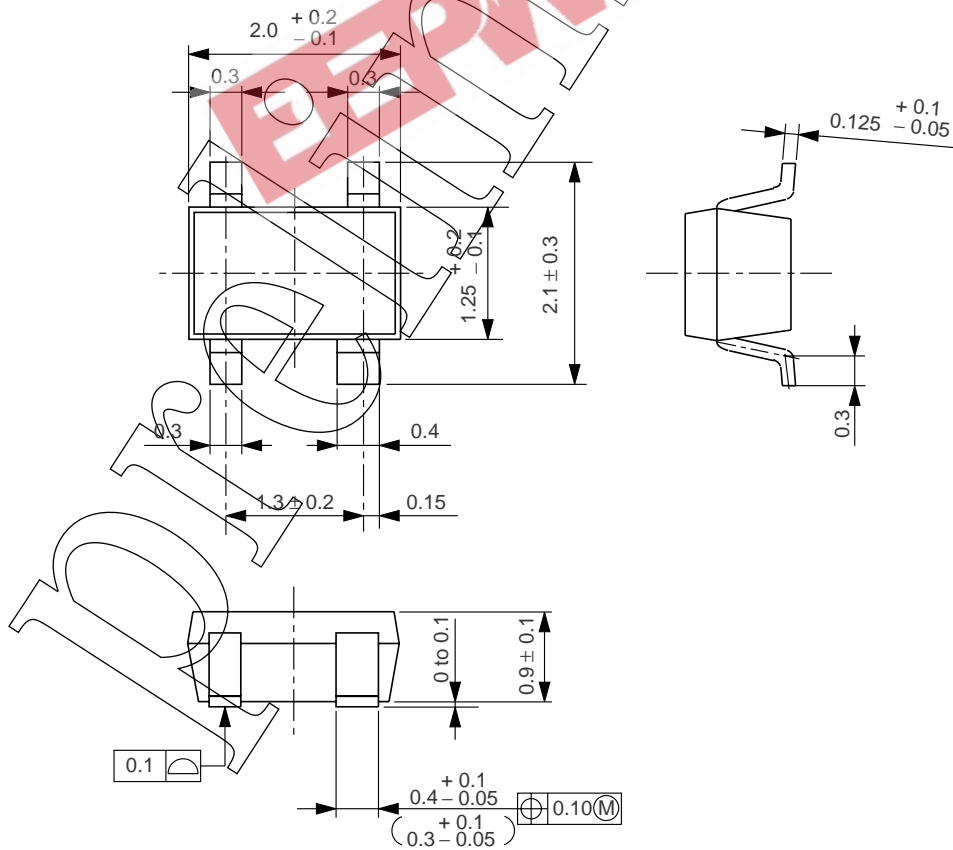

## BLOCK DIAGRAM

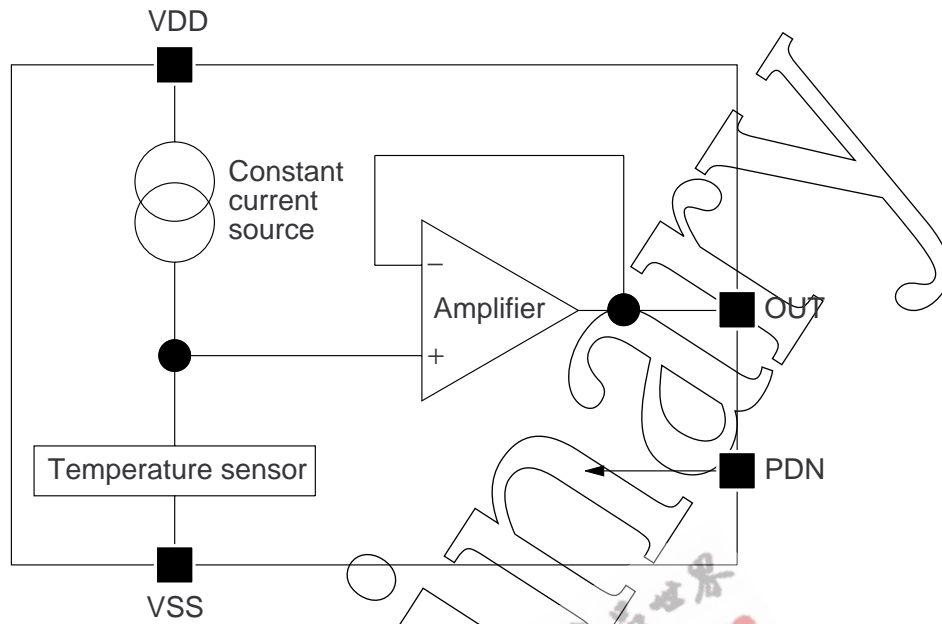

## PIN DESCRIPTION

Number	Name	Description
1	VDD	Positive power supply
2	VSS	Ground
3	PDN	Power down control. Power down when LOW.
4	OUT	Sensor output

1. Connect PDN to VDD when the power down function is not used.

## SPECIFICATIONS

### DC Characteristics

$V_{DD} = 5.0\text{ V}$ ,  $V_{SS} = 0\text{ V}$ ,  $T_a = -40\text{ to }100\text{ }^\circ\text{C}$  unless otherwise noted.

Parameter	Symbol	Condition	Rating			Unit	
			min	typ	max		
Current consumption	$I_{DD}$	No load	-	5.5	10.0	$\mu\text{A}$	
Output voltage <sup>1</sup>	$V_{OUT}$	$T_a = -30\text{ }^\circ\text{C}$	A× version	2.468	2.521	2.574	V
		$T_a = +25\text{ }^\circ\text{C}$		1.880	1.933	1.986	V
		$T_a = +100\text{ }^\circ\text{C}$		1.077	1.130	1.183	V
		$T_a = -30\text{ }^\circ\text{C}$	B× version	1.859	1.908	1.941	V
		$T_a = +25\text{ }^\circ\text{C}$		1.408	1.449	1.490	V
		$T_a = +100\text{ }^\circ\text{C}$		0.793	0.834	0.875	V
Temperature coefficient <sup>1, 2</sup>	$T_C$	$T_a = -30\text{ to }+100\text{ }^\circ\text{C}$	A× version	-	-10.7	-	$\text{mV}/^\circ\text{C}$
			B× version	-	-8.2	-	$\text{mV}/^\circ\text{C}$
Linearity <sup>3</sup>	$N_L$	$T_a = -20\text{ to }+80\text{ }^\circ\text{C}$	-	$\pm 0.5$	-	%	
Maximum capacitive load	$C_L$				100	$\text{pF}$	
Maximum output current load	$I_L$	$V_{DD} = 2.4\text{ V}$			$\pm 50$	$\mu\text{A}$	
		$V_{DD} = 4.5\text{ V}$			$\pm 250$	$\mu\text{A}$	
Start up time	$t_D$				300	$\mu\text{s}$	
PDN Input voltage	$V_{IH}$		$V_{DD} - 0.3$	-	-	V	
	$V_{IL}$		-	-	$V_{SS} + 0.3$	V	

1. Provisional value

2. Temperature coefficient:  $T_C = (V_{OUT} (@100^\circ\text{C}) - V_{OUT} (@-30^\circ\text{C})) / 130$

3. Linearity:  $N_L = (a/b) \times 100$

a: Maximum deviation between measured and approximate value in the range of  $-20\text{ }^\circ\text{C}$  to  $+80\text{ }^\circ\text{C}$ .

b: Measured value difference between the values at  $-20\text{ }^\circ\text{C}$  and  $+80\text{ }^\circ\text{C}$ .

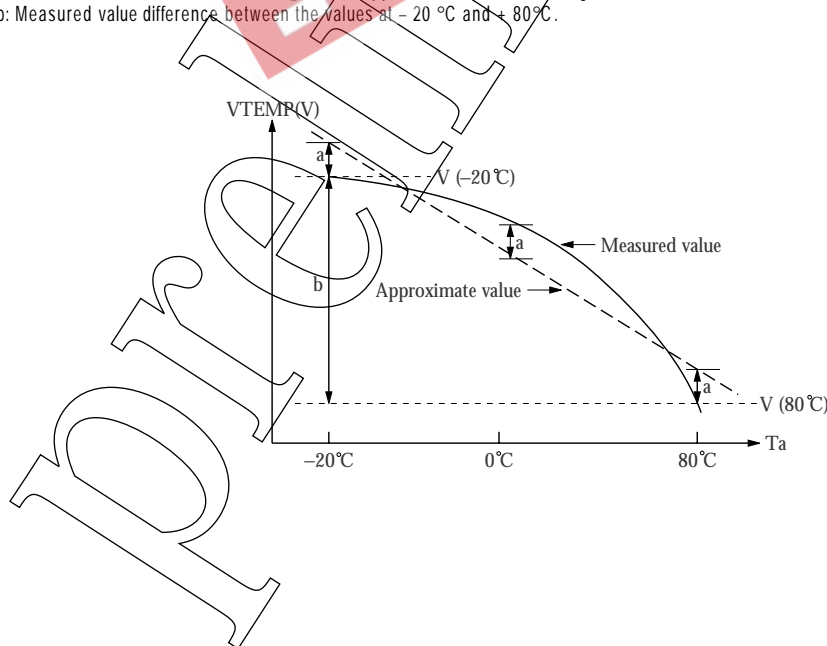

TYPICAL PERFORMANCE CHARACTERISTICS (Reference value)

SM6610A×

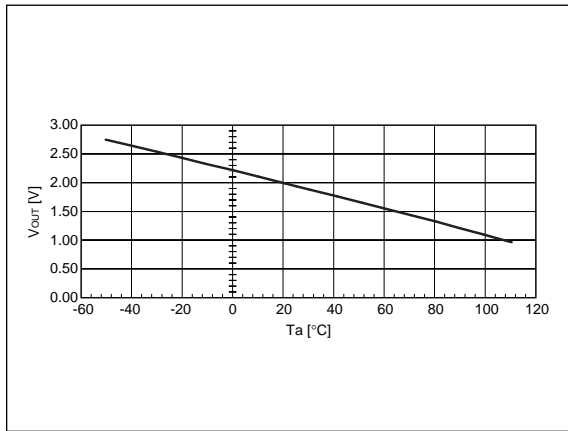

Figure 1. Temperature vs. Output voltage

SM6610B×

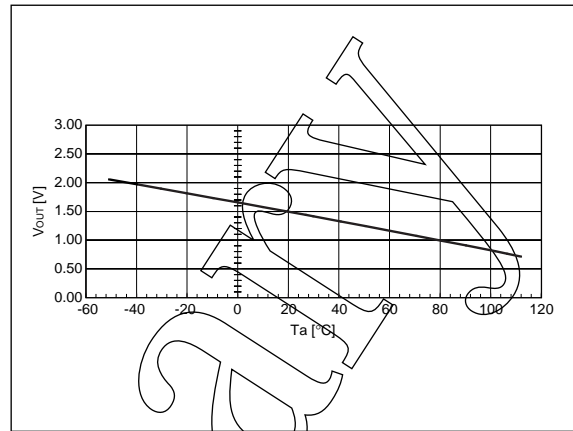

Figure 4. Temperature vs. Output voltage

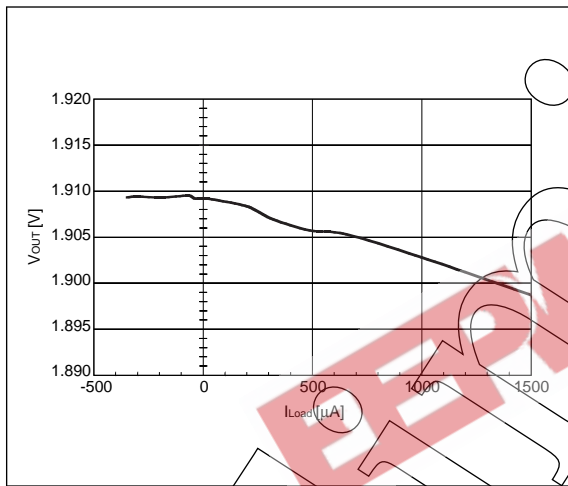

Figure 2. Load current vs. Output voltage  
(Ta = 25°C, VDD = 4.0V)

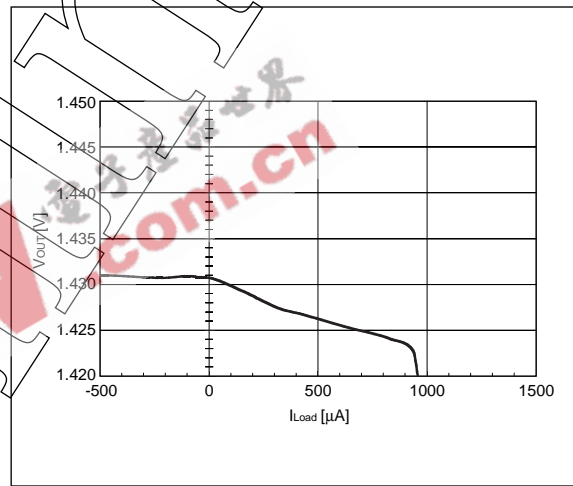

Figure 5. Load current vs. Output voltage  
(Ta = 25°C, VDD = 2.4V)

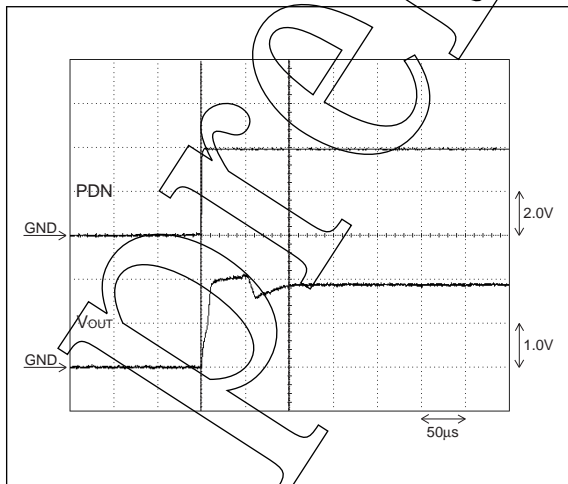

Figure 3. PDN start up response  
(Ta = 25°C, VDD = 4.0V, CL = 100pF)

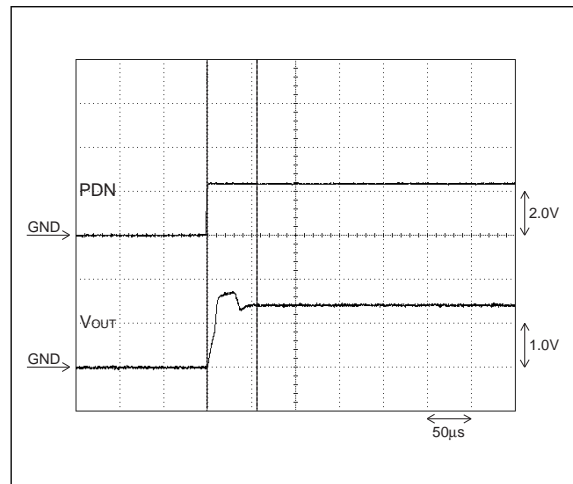

Figure 6. PDN start up response  
(Ta = 25°C, VDD = 2.4V, CL = 100pF)

Preliminary

電子產品世界  
eepw.com.cn

NIPPON PRECISION CIRCUITS INC. reserves the right to make changes to the products described in this data sheet in order to improve the design or performance and to supply the best possible products. Nippon Precision Circuits Inc. assumes no responsibility for the use of any circuits shown in this data sheet, conveys no license under any patent or other rights, and makes no claim that the circuits are free from patent infringement. Applications for any devices shown in this data sheet are for illustration only and Nippon Precision Circuits Inc. makes no claim or warranty that such applications will be suitable for the use specified without further testing or modification. The products described in this data sheet are not intended to use for the apparatus which influence human lives due to the failure or malfunction of the products. Customers are requested to comply with applicable laws and regulations in effect now and hereinafter, including compliance with export controls on the distribution or dissemination of the products. Customers shall not export, directly or indirectly, any products without first obtaining required licenses and approvals from appropriate government agencies.

**NPC**  
NIPPON PRECISION CIRCUITS INC.

NIPPON PRECISION CIRCUITS INC.

4-3, Fukuzumi 2-chome  
Koto-ku, Tokyo 135-8430, Japan  
Telephone: 03-3642-6661  
Facsimile: 03-3642-6698

NP9919BE 2000.02