

# SMBJ 5.0C - 170CA

## BIDIRECTIONAL TRANSIENT VOLTAGE SUPPRESSOR

**V<sub>BR</sub> : 6.8 - 200 Volts**

**P<sub>PK</sub> : 600 Watts**

### FEATURES :

- \* 600W surge capability at 1ms
- \* Excellent clamping capability
- \* Low inductance
- \* Response Time Typically < 1ns
- \* Typical I<sub>R</sub> less than 1μA above 10V

### MECHANICAL DATA

- \* Case : SMB Molded plastic
- \* Epoxy : UL94V-O rate flame retardant
- \* Lead : Lead Formed for Surface Mount
- \* Mounting position : Any
- \* Weight : 0.109 gram

SMB (DO-214AA)

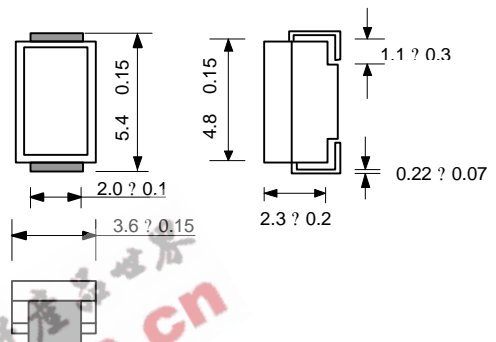

Dimensions in millimeter

### MAXIMUM RATINGS

Rating at T<sub>a</sub> = 25 °C ambient temperature unless otherwise specified.

Rating	Symbol	Value	Units
Peak Pulse Power Dissipation on 10/1000μs (1) waveform (Notes 1, 2, Fig. 4)	P <sub>PPM</sub>	Minimum 600	Watts
Peak Pulse Current on 10/1000μs waveform (Note 1, Fig. 3)	I <sub>PPM</sub>	See Table	Amps
Operating Junction and Storage Temperature Range	T <sub>J</sub> , T <sub>STG</sub>	- 55 to + 150	°C

### Note :

- (1) Non-repetitive Current pulse, per Fig. 3 and derated above T<sub>a</sub> = 25 °C per Fig. 1
- (2) Mounted on 5.0mm<sup>2</sup> (0.013mm) land areas.

UPDATE : MAY 10, 2000

# ELECTRICAL CHARACTERISTICS

Rating at Ta = 25 °C ambient temperature unless otherwise specified

TYPE	Marking Code	Breakdown Voltage @ I <sub>T</sub> ( Note 1 )			Reverse Stand-off Voltage	Maximum Reverse Leakage @ V <sub>WM</sub>	Maximum Peak Pulse Surge Current (See Fig. 3)	Maximum Clamping Voltage @ I <sub>PPM</sub>				
		V <sub>BR</sub> (V)		I <sub>T</sub>					V <sub>WM</sub>	I <sub>D</sub>	I <sub>PPM</sub>	V <sub>C</sub>
		Min.	Max.	(mA)					(V)	(μA)	(A)	(V)
SMBJ5.0C	606I	6.40	7.55	10	5.0	1600	62.5	9.6				
SMBJ5.0CA	656I	6.40	7.25	10	5.0	1600	65.2	9.2				
SMBJ6.0C	607C	6.67	8.45	10	6.0	1600	52.6	11.4				
SMBJ6.0CA	657C	6.67	7.67	10	6.0	1600	58.3	10.3				
SMBJ6.5C	607I	7.22	9.14	10	6.5	1000	48.7	12.3				
SMBJ6.5CA	657I	7.22	8.30	10	6.5	1000	53.6	11.2				
SMBJ7.0C	608E	7.78	9.86	10	7.0	400	45.1	13.3				
SMBJ7.0CA	658E	7.78	8.95	10	7.0	400	50.0	12.0				
SMBJ7.5C	609A	8.33	10.67	1.0	7.5	200	42.0	14.3				
SMBJ7.5CA	659A	8.33	9.58	1.0	7.5	200	46.5	12.9				
SMBJ8.0C	609G	8.89	11.3	1.0	8.0	100	40.0	15.0				
SMBJ8.0CA	659G	8.89	10.23	1.0	8.0	100	44.1	13.6				
SMBJ8.5C	6010	9.44	11.92	1.0	8.5	20	37.7	15.9				
SMBJ8.5CA	6510	9.44	10.82	1.0	8.5	20	41.7	14.4				
SMBJ9.0C	6011	10.0	12.6	1.0	9.0	10	35.5	16.9				
SMBJ9.0CA	6511	10.0	11.5	1.0	9.0	10	39.0	15.4				
SMBJ10C	6012	11.1	14.1	1.0	10	5.0	31.9	18.8				
SMBJ10CA	6512	11.1	12.8	1.0	10	5.0	35.3	17.0				
SMBJ11C	6013	12.2	15.4	1.0	11	5.0	29.9	20.1				
SMBJ11CA	6513	12.2	14.0	1.0	11	5.0	33.0	18.2				
SMBJ12C	6014	13.3	16.9	1.0	12	5.0	27.3	22.0				
SMBJ12CA	6514	13.3	15.3	1.0	12	5.0	30.2	19.9				
SMBJ13C	6015	14.4	18.2	1.0	13	5.0	25.2	23.8				
SMBJ13CA	6515	14.4	16.5	1.0	13	5.0	27.9	21.5				
SMBJ14C	6017	15.6	19.8	1.0	14	5.0	23.3	25.8				
SMBJ14CA	6517	15.6	17.9	1.0	14	5.0	25.8	23.2				
SMBJ15C	6018	16.7	21.1	1.0	15	5.0	22.3	26.9				
SMBJ15CA	6518	16.7	19.2	1.0	15	5.0	24.0	24.4				
SMBJ16C	6019	17.8	22.6	1.0	16	5.0	20.8	28.8				
SMBJ16CA	6519	17.8	20.5	1.0	16	5.0	23.1	26.0				
SMBJ17C	6020	18.9	23.9	1.0	17	5.0	19.7	30.5				
SMBJ17CA	6520	18.9	21.7	1.0	17	5.0	21.7	27.6				
SMBJ18C	6022	20.0	25.3	1.0	18	5.0	18.6	32.2				
SMBJ18CA	6522	20.0	23.3	1.0	18	5.0	20.5	29.2				
SMBJ20C	6024	22.2	28.1	1.0	20	5.0	16.7	35.8				
SMBJ20CA	6524	22.2	25.5	1.0	20	5.0	18.5	32.4				
SMBJ22C	6026	24.4	30.9	1.0	22	5.0	15.2	39.4				
SMBJ22CA	6526	24.4	28.0	1.0	22	5.0	16.9	35.5				
SMBJ24C	6029	26.7	33.8	1.0	24	5.0	14.0	43.0				
SMBJ24CA	6529	26.7	30.7	1.0	24	5.0	15.4	38.9				
SMBJ26C	6031	28.9	36.6	1.0	26	5.0	12.4	46.6				
SMBJ26CA	6531	28.9	33.2	1.0	26	5.0	14.2	42.1				
SMBJ28C	6033	31.1	39.4	1.0	28	5.0	12.0	50.0				
SMBJ28CA	6533	31.1	35.8	1.0	28	5.0	13.2	45.4				
SMBJ30C	6036	33.3	42.2	1.0	30	5.0	11.2	53.5				
SMBJ30CA	6536	33.1	38.3	1.0	30	5.0	12.4	46.6				

TYPE	Marking Code	Breakdown Voltage @ I <sub>T</sub> ( Note 1 )			Reverse Stand-off Voltage	Maximum Reverse Leakage @ V <sub>WM</sub>	Maximum Peak Pulse Surge Current (See Fig. 3)	Maximum Clamping Voltage @ IPPM
		V <sub>BR</sub> (V)		I <sub>T</sub>				
		Min.	Max.	(mA)	V <sub>WM</sub> (V)	I <sub>D</sub> (μA)	IPPM (A)	V <sub>C</sub> (V)
SMBJ33C	6040	36.7	46.5	1.0	33	5.0	10.2	59.0
SMBJ33CA	6540	36.7	42.2	1.0	33	5.0	11.3	53.3
SMBJ36C	6043	40.0	50.7	1.0	36	5.0	9.3	64.3
SMBJ36CA	6543	40.0	46.0	1.0	36	5.0	10.3	58.1
SMBJ40C	6048	44.4	56.3	1.0	40	5.0	8.4	71.4
SMBJ40CA	6548	44.4	51.1	1.0	40	5.0	9.3	64.5
SMBJ43C	6051	47.8	60.5	1.0	43	5.0	7.8	76.7
SMBJ43CA	6551	47.8	54.9	1.0	43	5.0	8.6	69.4
SMBJ45C	6054	50.0	63.3	1.0	45	5.0	7.5	80.3
SMBJ45CA	6554	50.0	57.5	1.0	45	5.0	8.3	72.7
SMBJ48C	6057	53.3	67.5	1.0	48	5.0	7.0	85.5
SMBJ48CA	6557	53.3	61.3	1.0	48	5.0	7.7	77.4
SMBJ51C	6061	56.7	71.8	1.0	51	5.0	6.6	91.1
SMBJ51CA	6561	56.7	65.2	1.0	51	5.0	7.3	82.4
SMBJ54C	6065	60.0	76.0	1.0	54	5.0	6.2	96.3
SMBJ54CA	6565	60.0	69.0	1.0	54	5.0	6.9	87.1
SMBJ58C	6070	64.4	81.6	1.0	58	5.0	5.8	103.0
SMBJ58CA	6570	64.4	74.1	1.0	58	5.0	6.4	93.6
SMBJ60C	6072	66.7	84.5	1.0	60	5.0	5.6	107
SMBJ60CA	6572	66.7	76.7	1.0	60	5.0	6.2	96.8
SMBJ64C	6076	71.1	90.1	1.0	64	5.0	5.3	114
SMBJ64CA	6576	71.1	81.8	1.0	64	5.0	5.8	103
SMBJ70C	6084	77.8	98.6	1.0	70	5.0	4.8	125
SMBJ70CA	6584	77.8	89.5	1.0	70	5.0	5.3	113
SMBJ75C	6090	83.3	105.7	1.0	75	5.0	4.5	134
SMBJ75CA	6590	83.3	95.8	1.0	75	5.0	4.9	121
SMBJ78C	6093	86.7	109.8	1.0	78	5.0	4.3	139
SMBJ78CA	6593	86.7	99.7	1.0	78	5.0	4.7	126
SMBJ85C	60B0	94.4	119.2	1.0	85	5.0	3.9	151
SMBJ85CA	65B0	94.4	108.2	1.0	85	5.0	4.4	137
SMBJ90C	60B1	100	126.5	1.0	90	5.0	3.8	160
SMBJ90CA	65B1	100	115.5	1.0	90	5.0	4.1	146
SMBJ100C	60B2	111	141.0	1.0	100	5.0	3.4	179
SMBJ100CA	65B2	111	128.0	1.0	100	5.0	3.7	162
SMBJ110C	60B3	122	154.5	1.0	110	5.0	3.0	196
SMBJ110CA	65B3	122	140.5	1.0	110	5.0	3.4	177
SMBJ120C	60B4	133	169.0	1.0	120	5.0	2.8	214
SMBJ120CA	65B4	133	153.0	1.0	120	5.0	3.1	193
SMBJ130C	60B5	144	182.5	1.0	130	5.0	2.6	231
SMBJ130CA	65B5	144	165.5	1.0	130	5.0	2.9	209
SMBJ150C	60B8	167	211.5	1.0	150	5.0	2.2	268
SMBJ150CA	65B8	167	192.5	1.0	150	5.0	2.5	243
SMBJ160C	60B9	178	226.0	1.0	160	5.0	2.1	287
SMBJ160CA	65B9	178	205.0	1.0	160	5.0	2.3	259
SMBJ170C	60D0	189	239.5	1.0	170	5.0	2.0	304
SMBJ170CA	65D0	189	217.5	1.0	170	5.0	2.2	275

**Note:**

- ( 1 ) V<sub>BR</sub> measured after I<sub>T</sub> applied for 300 μs., I<sub>T</sub> = square wave pulse or equivalent.
- ( 2 ) Surge Current Waveform per Fig. 3 and Derate per Fig. 1.
- ( 3 ) A TransZorb TVS is normally selected according to the reverse "Stand Off Voltage" (V<sub>WM</sub>) which should be equal to or greater than the DC or continuous peak operating voltage level.

## RATING AND CHARACTERISTIC CURVES ( SMBJ5.0C - SMBJ170CA )

**FIG.1 - PULSE DERATING CURVE**

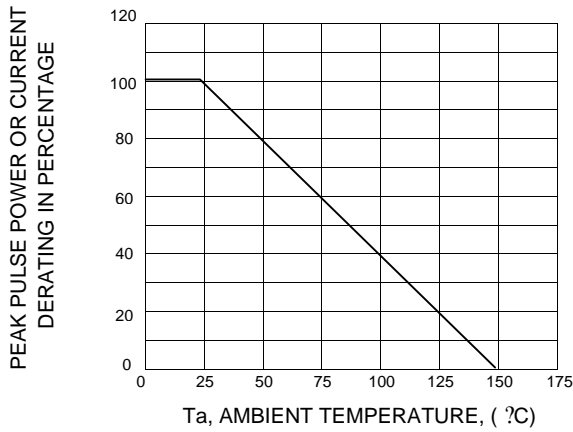

**FIG.2 - TYPICAL JUNCTION CAPACITANCE**

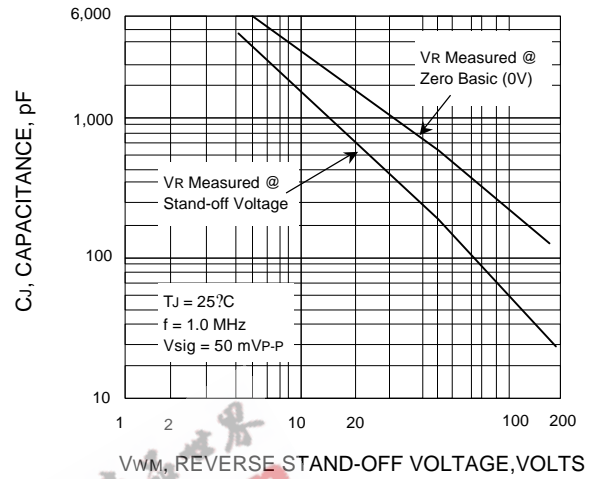

**FIG.3 - PULSE WAVEFORM**

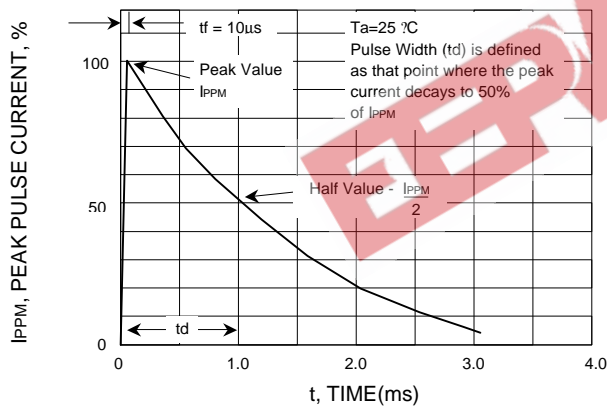

**FIG.4 - PEAK PULSE POWER RATING CURVE**

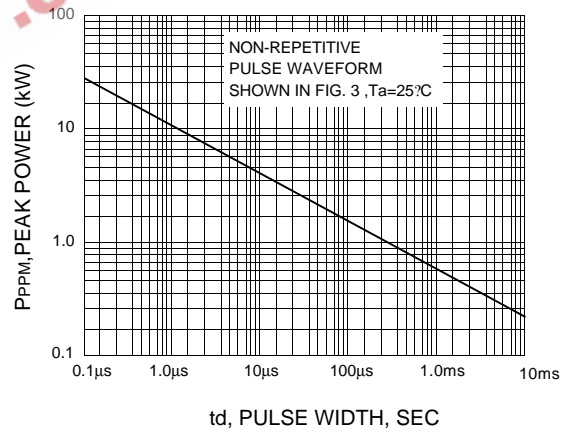

**FIG.5 - MAXIMUM NON-REPETITIVE PEAK FORWARD SURGE CURRENT**

